

GXS 9005



Reservedelsliste
Spare parts list
Ersatzteilliste
Liste de pièce de rechange

X2

JF-STOLL

Always state the serial number and if possible the year of the machine when ordering spare parts whereby you save time and money and facilitates matters for us.
Please enter the number of your machine here:

No..... Delivered on the / 20.....

Appropriate when ordering parts.

The serial number is located as shown on the figure.

Bei Ersatzteilbestellungen ist die Fabrikationsnummer Ihrer Maschine unbedingt anzugeben. Das erspart Ihnen Zeit, Geld und Ärger und erleichtert uns die Abfertigung.
Tragen Sie die Nummer Ihrer Maschine bitte hier ein:

Nr..... Geliefert am / 20.....

dann haben Sie bei Ersatzteilbestellungen immer die Nummer bei der Hand.

Die Fabrikationsnummer ist im Rahmen eingeschlagen, siehe Figur.

Lorsque vous commandez des pièces détachées, indiquez toujours le numéro de série de votre machine et si possible son année de fabrication. Vous éviterez des pertes de temps et vous nous faciliterez le travail.

Prière de noter ici le numéro de série de votre machine:

Numéro..... Livrée le / 20.....

Ceci vous sera utile lorsque vous commanderez des pièces.

Le numéro de série est gravé dans le cadre comme indiqué sur la figure.

Bestiller De reservedele så opgiv venligst maskinens fabrikationsnummer og eventuelt købsår. Det sparer Dem tid, penge og ærgrelser og os unødigt besvær.
De kan notere nummeret på Deres maskine her:

Nr..... Leveret den / 20.....

så har De det ved hånden, når De eventuelt skal bestille reservedele.

Fabrikationsnummeret findes indhugget i rammen, som vist på figuren.

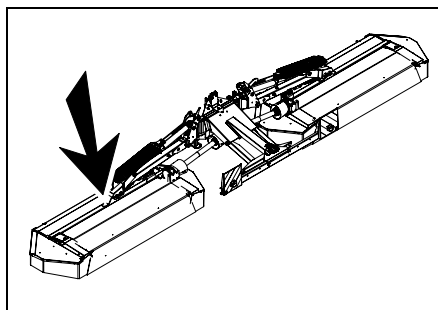

SPARE PARTS BOOK ERSATZTEILKATALOG CATALOGUE DE PIÈCES RESERVEDELSKATALOG

The book is divided into 5 passages:

1. Description of the spare part book.
2. Number key for assembly parts.
3. Number key showing on which figures the spare part numbers can be found.
4. Figure key showing on which figures the parts can be found.
5. Spare parts list.

Der Katalog ist in 5 Abschnitte eingeteilt:

1. Beschreibung des Ersatzteilkataloges.
2. Nummernschlüssel für Montagezubehör.
3. Nummernschlüssel mit Angabe der jeweiligen Ersatzteilnummer.
4. Figurliste mit Angabe, auf welche Figuren die Teile zu finden sind.
5. Ersatzteilliste.

Le catalogue est divisé en 5 sections:

1. Description du catalogue de pièces.
2. Liste de pièces de montage.
3. Numéros des pièces de rechange indiquant le numéro de figure.
4. Liste des figures indiquant sur quelle figure se trouvent les pièces.
5. Liste de pièces de rechange.

Kataloget er opdelt i 5 afsnit:

1. Beskrivelse af reservedelskataloget.
2. Nummernøgle for monteringsdele.
3. Nummernøgle - viser på hvilke figurer reservedelsnumrene findes.
4. Figurnøgle - viser på hvilke figurer delene findes.
5. Reservedelsliste.

**Description of the spare parts book:
Beschreibung des Ersatzteilkataloges:
Discription du catalogue de piéces:
Beskrivelse af reservedelskataloget:**

The spare parts book is built up as follows:

Fig. 01-29 Standard Fig. 50-59 Hub
Fig. 30-39 Gear Fig. 60-79 Variation of standard (Accessory)
Fig. 40-49 PTO drives Fig. 80- Accessory

Der Ersatzkatalog ist so aufgebaut:

Fig. 01-29 Standard Fig. 50-59 Nabe
Fig. 30-39 Getriebe Fig. 60-79 Variation vom Standard (Zubehór)
Fig. 40-49 Gelenkwellen Fig. 80- Zubehór

Le catalogue de piéces est arrangé comme suit:

Fig. 01-29 Standard Fig. 50-59 Moyeu
Fig. 30-39 Boítier Fig. 60-79 Variation du standard (Accessoire)
Fig. 40-49 Arbres á cardan Fig. 80- Accessoire

Reservedelskataloget er opbygget således:

Fig. 01-29 Standard Fig. 50-59 Nav
Fig. 30-39 Gear Fig. 60-79 Variation af standard (Tilbehór)
Fig. 40-49 Kraftoverføringsakslér Fig. 80- Tilbehór

Postion No.:

The position No. marked "(") is not standard.
Is delivered as accessory.

Positionsnummer:

Die Positionsnummer, die mit "(") gezeichnet ist, ist nicht der Standard.
Wird als Zubehór geliefert.

No de pos.:

Le numéro de position marqué d'un "(") n'est pas une piéce standard.
Livrée comme accessoire.

Pos. nr.:

Positionsnummer mærket med "(") er ikke standard.
Leveres som tilbehór

Article no.:

The article no. marked "T" is not standard. Is delivered as accessories.
the article no. marked "+":
Modification is being made.

Warennummer:

Ist eine Warennummer mit "T" gekennzeichnet, wird sie als Zubehór geliefert.
Eine Warennummer mit "+" ist als Modifikation unterwegs.

No. D'article:

Le no d'article marqué d'un "T" n'est pas un article standard. Livré comme accessoire.
No. d'article marqué de "+":
Une modification viendra.

Varenr.:

Varennummer mærket med "T" er ikke standard. Leveres som tilbehór.
Varennummer mærket med "+" :
ændring undervejs.

POS.	VARENUMMER	ANTAL	BENÆVNELSE	BEZEICHNUNG	DESIGNATION	HERTIL, DAJU TO THIS, À CE CI
33.	1340-9153 T	2	KRYDS KRUTZGARNITUR >=0003219 <=0003448	CENTRE		1341-9187 1
33.1	1350-7005	2	KRYDS KRUTZGARNITUR >=0003219	CENTRE		1350-9052 4 1350-9104 1
34.	1340-0196	1	PROFILAKSEL PROFILGABEL >=0003219 <=0003448	PROFIL FORK		
34.1	1350-8008	1	PROFILAKSEL PROFILGABEL >=0003249	PROFIL FORK		

Designation:

>=0003219 <=0003448
Spare part used for machine from serial No. 3219 up to No. 3448 both Nos. included.

Benennung:

>=0003219 <=0003448
Ersatzteil für Maschinen von Fabrikationsnummer 3219 bis Nr. 3448.

Désignation:

>=0003219 <=0003448
Piéce de rechange employée sur machines á partir de no de série 3219 jusqu'à et y compris no 3448.

Benævneelse:

>=0003219 <=0003448
Reservedel anvendt på maskine fra og med fabrikationsnummer 3219 til og med nr. 3448

Quantity:

States quantity of parts for machine.
In connection with subassemblies:
Quantity for the assembly.

Anzahl:

Anzahl Teile je Maschine.
Bei Untersammlungen:
Anzahl je Sammlng.

Quantité:

Quantité de piéces par machine.
Pour les sous-assemblages: piéces par assemblage.

Antal:

Antal dele pr. maskine.
Ved undersamlinger: dele pr. samling.

To this:

States which and how many mounting assemblies (screws, nuts, discs etc.) are used with the spare part.
See under number key for assembly parts

Dazu:

Angabe von Montageanteilen (Schrauben, Muttern, Scheiben usw.) die zusammen mit dem Ersatzteil angewendet werden sollen. Siehe Nummerschlüssel für Montagezubehór.

Pour ceci:

Indique lesquelles et combien de piéces de montage (vis, écrous, rondelles etc.) sont employées avec la piéce de rechange. Voir dans la liste de numéros pour piéces de montage.

Hertil:

Angiver hvilke og hvor mange monteringsdele (skruer, møtrikker, skiver osv.) der anvendes sammen med reservedelen. Se under nummermøgle for monteringsdele.

VARENUMMER	BENÆVNELSE	BEZEICHNUNG	DESIGNATION
1165-0130	KABELBINDER	KABELHALTEBAENDER	CABLE TIES
1165-0186	DBI-DUT NR. 80	DBI-DUT NR. 80	DBI-DUT NR. 80
1213-2126	STÅLSÆTSKRUE M8-15	ST. SETSCHRAUBE M8-15	STEEL SET SCREW M8-15
1213-2222	STÅLSÆTSKRUE M8-20	ST. SETSCHRAUBE M8-20	STEEL SET SCREW M8-20
1213-2224	STÅLSÆTSKRUE M8-25	ST. SETSCHRAUBE M8-25	STEEL SET SCREW M8-25
1213-3222	STÅLSÆTSKRUE M10-20	ST. SETSCHRAUBE M10-20	STEEL SET SCREW M10-20
1213-3224	STÅLSÆTSKRUE M10-25	ST. SETSCHRAUBE M10-25	STEEL SET SCREW M10-25
1213-3322	STÅLSÆTSKRUE M10-30	ST. SETSCHRAUBE M10-30	STEEL SET SCREW M10-30
1213-3622	STÅLSÆTSKRUE M10-60	ST. SETSCHRAUBE M10-60	STEEL SET SCREW M10-60
1213-4222	STÅLSÆTSKRUE M12-20	ST. SETSCHRAUBE M12-20	STEEL SET SCREW M12-20
1213-4224	STÅLSÆTSKRUE M12-25	ST. SETSCHRAUBE M12-25	STEEL SET SCREW M12-25
1213-4322	STÅLSÆTSKRUE M12-30	ST. SETSCHRAUBE M12-30	STEEL SET SCREW M12-30
1213-4327	STÅLSÆTSKRUE M12-35 KVAL 10.9	ST. SETSCHRAUBE M12-35 Q 10.9	STEEL SET SCREW M12-35 Q 10.9
1213-4622	STÅLSÆTSKRUE M12-60	ST. SETSCHRAUBE M12-60	STEEL SET SCREW M12-60
1213-5324	STÅLSÆTSKRUE M16-35	ST. SETSCHRAUBE M16-35	STEEL SET SCREW M16-35
1213-5424	STÅLSÆTSKRUE M16-45	ST. SETSCHRAUBE M16-45	STEEL SET SCREW M16-45
1213-6422	STÅLSÆTSKRUE M20-40	ST. SETSCHRAUBE M20-40	STEEL SET SCREW M20-40
1214-1101	STÅLSÆTSKRUE M4-40	ST. SETSCHRAUBE M4-40	STEEL SET SCREW M4-40
1214-1126	STÅLSÆTSKRUE M6-45 GALV.	STAHLSCHRAUBE M6-45 GALV.	STEEL SET SCREW M6-45 GALV.
1214-2122	STÅLSKRUE M8-35	STAHLSECHSKANTSCHRAUBE M8-35	STEEL SCREW M8-35
1214-2126	STÅLSKRUE M8-45	STAHLSECHSKANTSCHRAUBE M8-45	STEEL SCREW M8-45
1214-2226	STÅLSKRUE M8-60	STAHLSECHSKANTSCHRAUBE M8-60	STEEL SCREW M8-60
1214-3122	STÅLSKRUE M10-45	STAHLSECHSKANTSCHRAUBE M10-45	STEEL SCREW M10-45
1214-3228	STÅLSKRUE M10-65 KV. 8.8	STAHLSECHSKANTSCHR. M10-65 Q8.8	STEEL SCHREW M10-65 Q 8.8
1214-4228	STÅLSKRUE M12-65 KV. 10.9	STAHLSCHRAUBE M12-65 KV. 10.9	STEEL SCREW M12-65 Q. 10.9
1214-4430	STÅLSÆTSKRUE M12-140	STAHLSCHRAUBE M12-140	STEEL SET SCREW M12-140
1215-2222	BREÐESKRUE M8-20	FLACHRUNDSCHRAUBE M8-20	CARRIAGE SCREW M8-20
1215-3226	BREÐESKRUE M10-25 KVAL. 8.8	FLACHRUNDSCHRAUBE M10-25 Q 8.8	CARRIAGE SCREW M10-25 Q 8.8
1215-3228	BREÐESKRUE M10-20 KV 8.8	FLACHRUNDSCHRAUBE M10-20 Q 8.8	CARRIAGE SCREW M10-20 Q 8.8
1215-3320	BREÐESKRUE M10-30 KV 8.8	FLACHRUNDSCHRAUBE M10-30 Q 8.8	CARRIAGE SCREW M10-30 Q 8.8
1215-4220	BREÐESKRUE M12-25 KV. 8.8	FLACHRUNDSCHRAUBE M12-25	CARRIAGE SCREW M12-25 Q. 8.8
1216-1156	MASKINSKRUE R/H M5-15	ZYLINDERSCHRAUBE M5-15	MACHINE SCREW ROUNDH. M5-15
1216-1324	MASKINSKRUE R/H M5-35	ZYLINDERSCHRAUBE M5-35	MACHINE SCREW ROUNDH. M5-35
1219-0210	SKRUE M10-30 12.9 DELTA B	SCHRAUBE M10-30 12.9 DELTA B	SCREW M10-30 12.9 DELTA B
1219-0217	UNBRACOSKRUE M8-20 MSP	INNENSECHSK. M8-20 MSP	ALLEN SCREW M8-20 MSP
1219-0245	UNBRACOSKRUE M12-30 MC	INNENSECHSK. SCHR. M12-30 MC	ALLEN SCREW M12-30 MC
1219-0266	UNBRACOSKRUE M10-30	INNENSECHSKANTSCHRAUBE M10-30	ALLEN SCREW M10-30
1219-0290	SKRUE CH M12-35	SCHRAUBE M12-35	SCREW CH M12-35
1219-0404	ØTÆBOLT M10-17	AUGENBOLZEN M10-17	EYE BOLT M10-17
1219-0599	SELVSKÆRENDE SKRUE M6-20/M6SF	SCHRAUBE M6-40/M6SF	SCREW M6-40/M6SF
1220-1321	NYLOC MØTRIK M4 DIN 985-8	NYLOC MUTTER M4 DIN 985-8	NYLOC NUT M4 DIN 985-8
1220-1322	NYLOC MØTRIK M5	NYLOC MUTTER M5	NYLOC NUT M5
1220-1323	NYLOC MØTRIK M6	NYLOC MUTTER M6	NYLOC NUT M6
1220-2321	NYLOC MØTRIK M8	NYLOC MUTTER M8	NYLOC NUT M8
1220-3122	STÅLMØTRIK M10	STAHLMUTTER M10	STEEL NUT M10
1220-3321	NYLOC MØTRIK M10	NYLOC MUTTER M10	NYLOC NUT M10
1220-3323	NYLOC MØTRIK M10 KVAL 10.9	NYLOC MUTTER M10 Q. 10.9	NYLOC NUT M10 Q. 10.9
1220-3922	MØTRIK M10	MUTTER M10	NUT M10
1220-3924	MØTRIK M10	MUTTER M10	NUT M10
1220-4122	STÅLMØTRIK M12	STAHLMUTTER M12	STEEL NUT M12
1220-4321	NYLOC MØTRIK M12	NYLOC MUTTER M12	NYLOC NUT M12
1220-4323	NYLOC MØTRIK M12 KV 10	NYLOC MUTTER M12 Q 10	NYLOC NUT M12 Q 10
1220-5122	STÅLMØTRIK M16	STAHLMUTTER M16	STEEL NUT M16
1220-5321	NYLOC MØTRIK M16	NYLOC MUTTER M16	NYLOC NUT M16
1220-6122	STÅLMØTRIK M20	STAHLMUTTER M20	STEEL NUT M20
1241-1101	SPÆNDESKIVE 4,3-12-1 GALV.	SCHIBE 4,3-12-1 GALV.	WASHER 4,3-12-1 GALV.
1241-1202	SPÆNDESKIVE 8,4-16-1,6	SCHIBE 8,4-16-1,6	WASHER 8,4-16-1,6
1241-1203	SPÆNDESKIVE 6,5-13-1,2	SCHIBE 6,5-13-1,2	WASHER 6,5-13-1,2
1241-1206	SPÆNDESKIVE 6,4-18-1,6	SCHIBE 6,4-18-1,6	WASHER 6,4-18-1,6
1241-1304	SPÆNDESKIVE 8-22-1,5	SCHIBE 8-22-1,5	WASHER 8-22-1,5
1241-1407	SKIVE	SCHIBE	WASHER
1241-2401	SPÆNDESKIVE 11-20-2,5	SCHIBE 11-20-2,5	WASHER 11-20-2,5
1241-2402	SPÆNDESKIVE 10,5-20-2,0	SCHIBE 10,5-20-2,0	WASHER 10,5-20-2,0
1241-2404	SPÆNDESKIVE 10-36-2	SCHIBE 10-36-2	WASHER 10-36-2
1241-2502	SPÆNDESKIVE 10,5-22-3	SCHIBE 10,5-22-3	WASHER 10,5-22-3
1241-2505	SPÆNDESKIVE 12,5-32-3	SCHIBE 12,5-32-3	WASHER 12,5-32-3
1241-3403	SPÆNDESKIVE 13-25-2,5	SCHIBE 13-25-2,5	WASHER 13-25-2,5
1241-4304	SPÆNDESKIVE 17-30-1,5	SCHIBE 17-30-1,5	WASHER 17-30-1,5
1241-4505	SPÆNDESKIVE 17-28-3	SCHIBE 17-28-3	WASHER 17-28-3
1241-4601	SPÆNDESKIVE 17,5-42-4	SCHIBE 17,5-42-4	WASHER 17,5-42-4
1241-6702	SPÆNDESKIVE 29-42-5	SCHIBE 29-42-5	WASHER 29-42-5
1241-7601	SPÆNDESKIVE 30-56-4	SCHIBE 30-56-4	WASHER 30-56-4
1241-7802	SPÆNDESKIVE 37-52-6	SCHIBE 37-52-6	WASHER 37-52-6
1241-8705	SPÆNDESKIVE 36-60-5	SCHIBE 36-60-5	WASHER 36-60-5
1241-8907	SPÆNDESKIVE	SCHIBE	WASHER
1241-9982	SPECIALSKIVE	SONDERSCHIBE	SPECIAL WASHER
1251-3204	SPÆNDESTIFT 5,0-30	SPANNSTIFT 5,0-30	SPECIAL PIN 5,0-30
1251-3501	SPÆNDESTIFT 5-60	SPANNSTIFT 5-60	SPECIAL PIN 5-60
1251-3601	SPÆNDESTIFT 5-70	SPANNSTIFT 5-70	SPECIAL PIN 5-70
1251-5401	SPÆNDESTIFT 7-50	SPANNSTIFT 7-50	SPECIAL PIN 7-50
1251-5406	SPÆNDESTIFT 7-55	SPANNSTIFT 7-55	SPECIAL PIN 7-55
1251-5503	SPÆNDESTIFT 8-60	SPANNSTIFT 8-60	SPECIAL PIN 8-60

FIGURNØGLE - FIGURSCHLÜSSEL - FIGURE KEY - LISTE DE FIGURES

GXS-0005/1

NUMMERNØGLE - NUMMERSCHLUSSEL - NUMBER KEY - LISTE DES NUMEROS

VARENUMMER	FIGUR	POS.	VARENUMMER	FIGUR	POS.	VARENUMMER	FIGUR	POS.	VARENUMMER	FIGUR	POS.
2365-893X	2.	15.									
3085-705X	10.	5.									
3085-738A	10.	4.									
3085-747X	10.	1.									
3087-449A	9.	6.									
3088-050X	11.	19.									
3088-076X	11.	20.									
3088-078X	11.	9.									
3088-079X	11.	10.									
3088-536X	9.	3.									
3088-539X	9.	2.									
3088-541X	9.	1.									
3088-549X	8.	17.									
3088-554X	8.	16.									
3088-563X	8.	12.									
3088-564X	8.	11.									
3088-571X	8.	9.									
3088-575X	8.	10.									
3113-233X	1.	9.									
3113-233X	30.	0.									
3210-436X	9.	14.									
3225-578A	8.	1.									
3225-578A	31.	0.									
3229-517A	9.	4.									
3279-502X	11.	8.									
3321-980X	2.	7.									
3322-120A	2.	9. 1									
3322-120X	2.	9.									
3322-124A	2.	6. 1									
3322-124X	2.	6.									
3325-291X	6.	32.									
3325-291X	6. 1	32.									
3325-291X	7.	32.									
3325-291X	7. 1	32.									
3325-595X	6.	15.									
3325-595X	6. 1	15.									
3325-595X	7.	15.									
3325-595X	7. 1	15.									
3325-611X	8.	3.									
3325-612X	8.	2.									
3325-656X	2.	1.									
3362-143X	80.	14.									
3365-073A	1.	17.									
3365-088X	5.	2.									
3365-122A	1.	21.									
3365-124B	1.	15.									
3365-157X	4.	7.									
3365-227X	5.	16.									
3365-259X	6.	26.									
3365-259X	7.	26.									
3365-260X	6.	27.									
3365-260X	7.	27.									
3365-295X	5.	10.									
3365-299X	3.	1.									
3365-299X	5.	11.									
3365-398X	3.	2.									
3365-398X	5.	1.									
3365-410X	1.	10.									
3365-830X	2.	4.									
3365-870X	4.	5.									
3365-873X	4.	6.									
3365-876X	4.	8.									
3365-877X	4.	9.									
3365-907X	1.	16.									
3365-909X	1.	18.									
3889-252X	1.	99.									
3889-296X	6.	99.									
3889-296X	6. 1	99.									
3889-296X	7.	99.									
3889-296X	7. 1	99.									

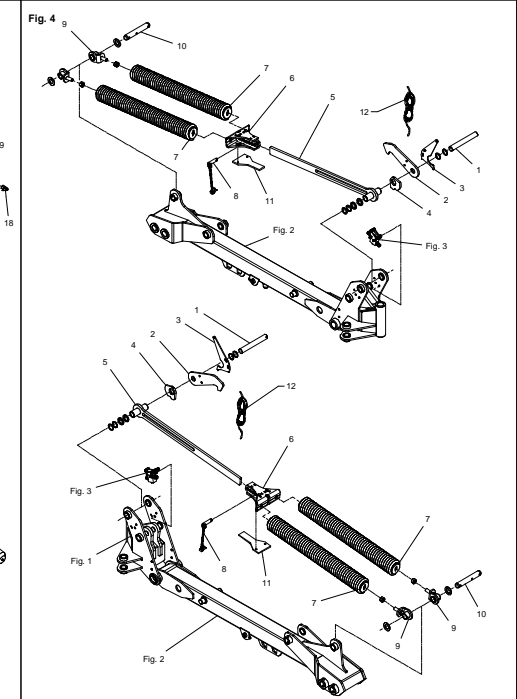
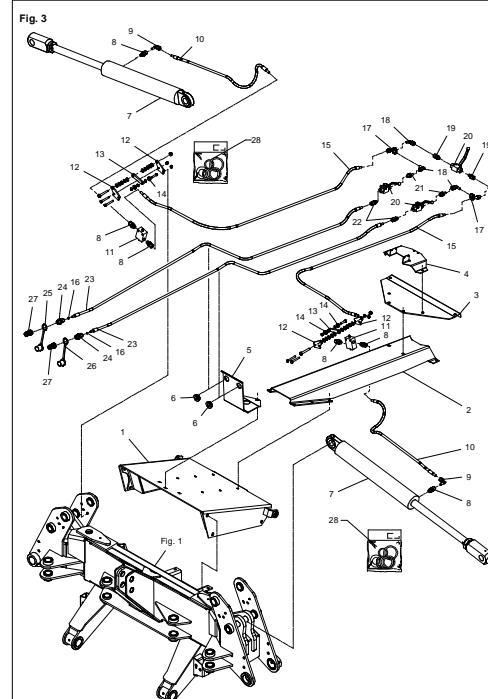
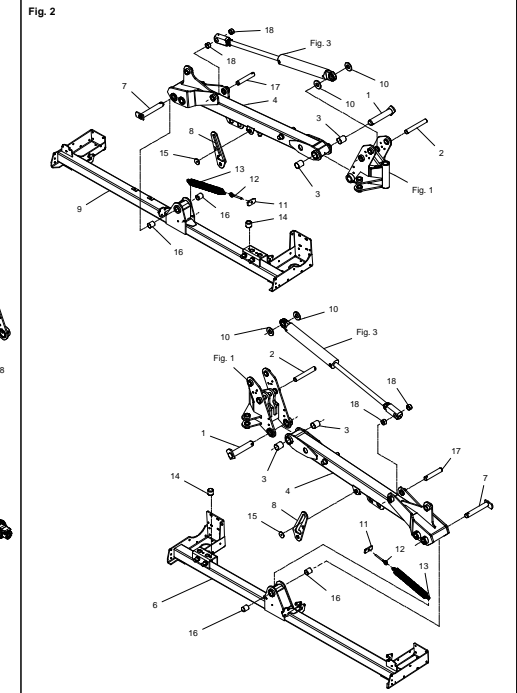
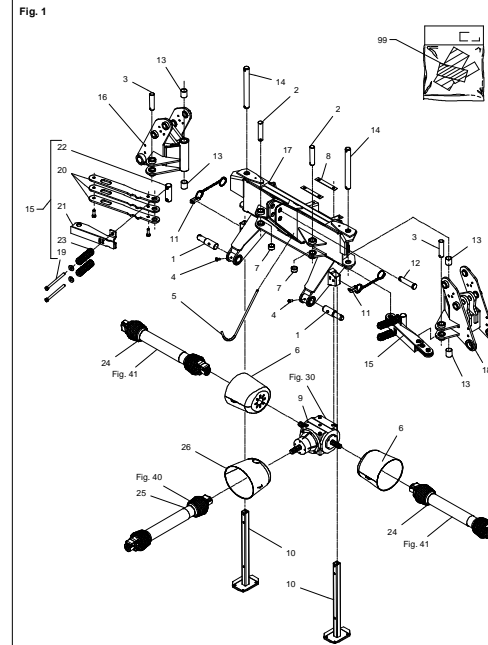

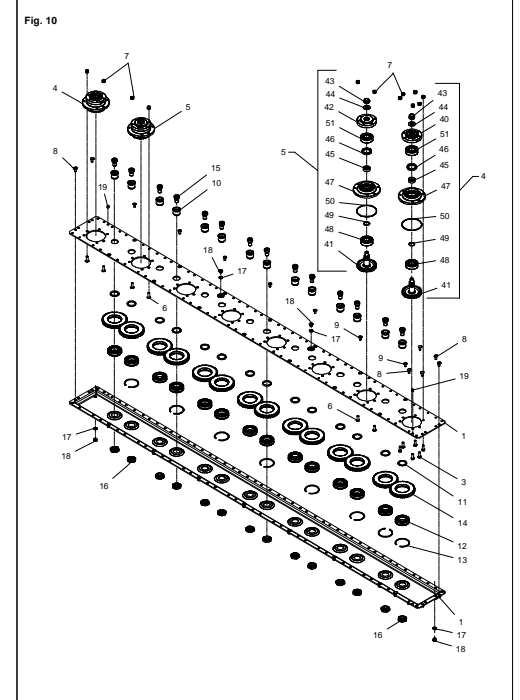
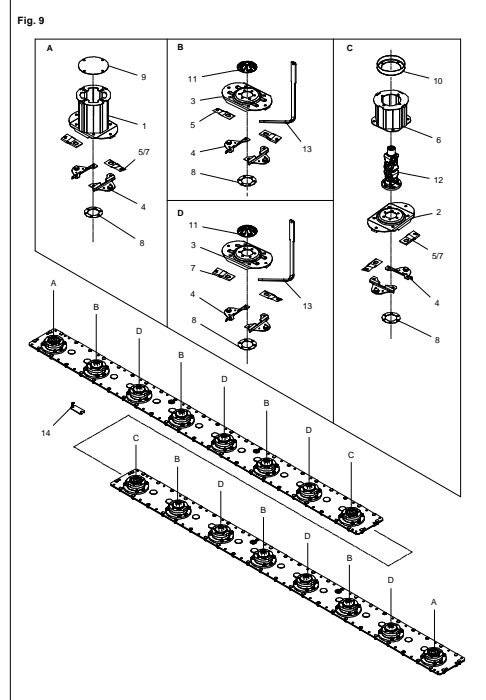
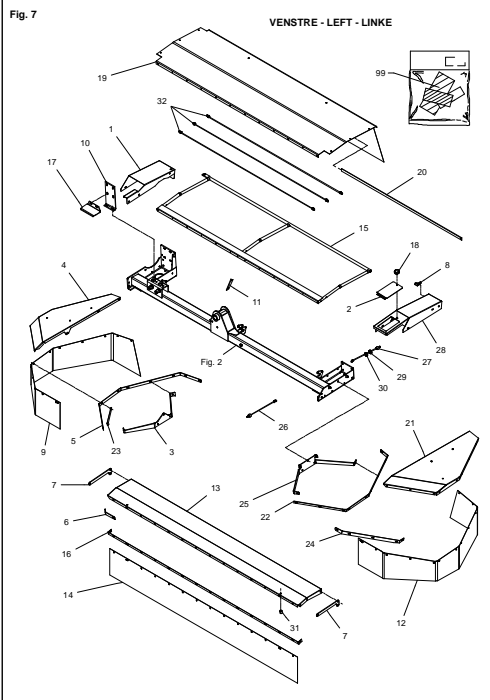
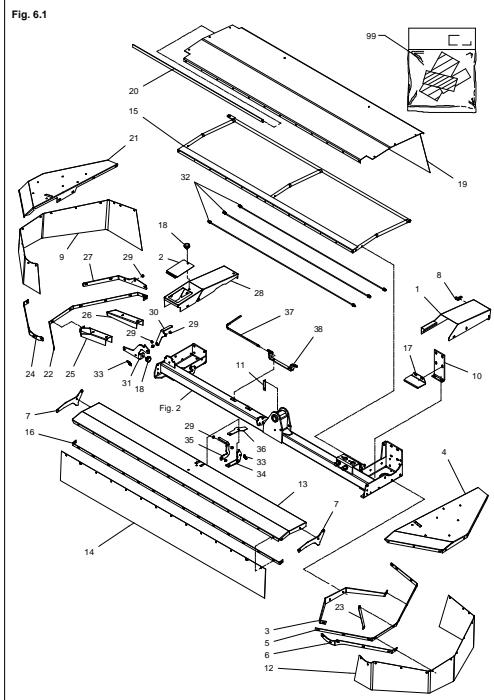
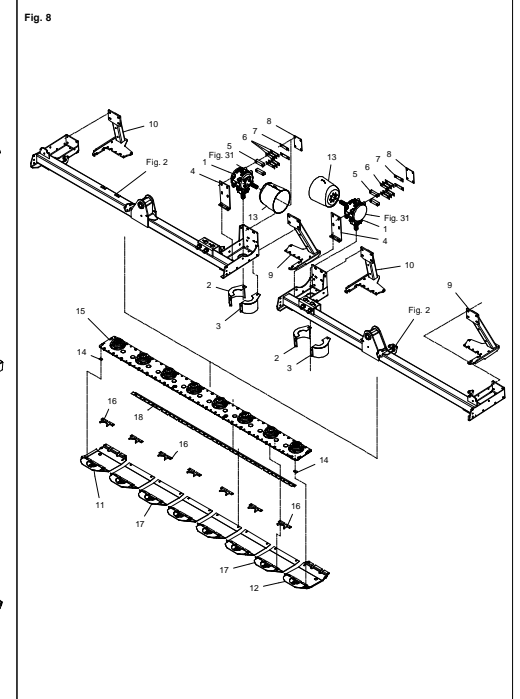
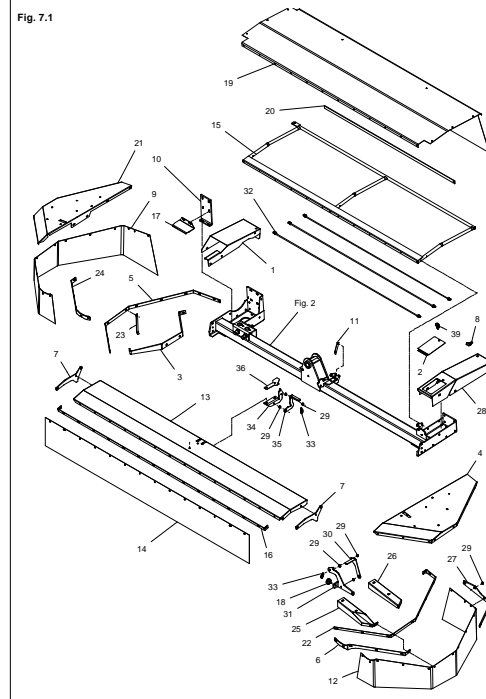
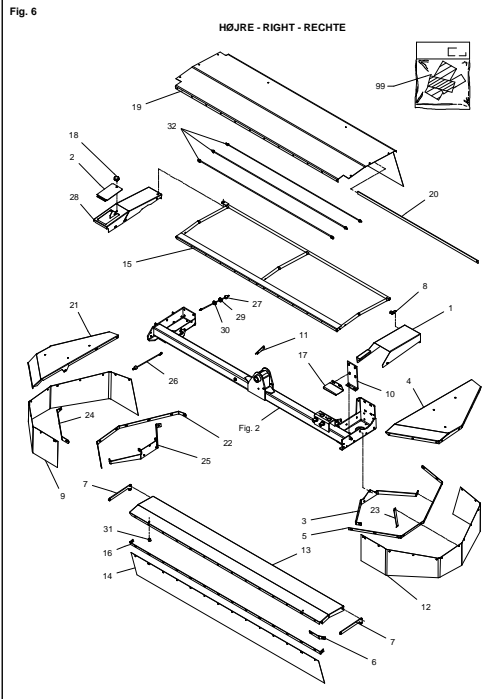
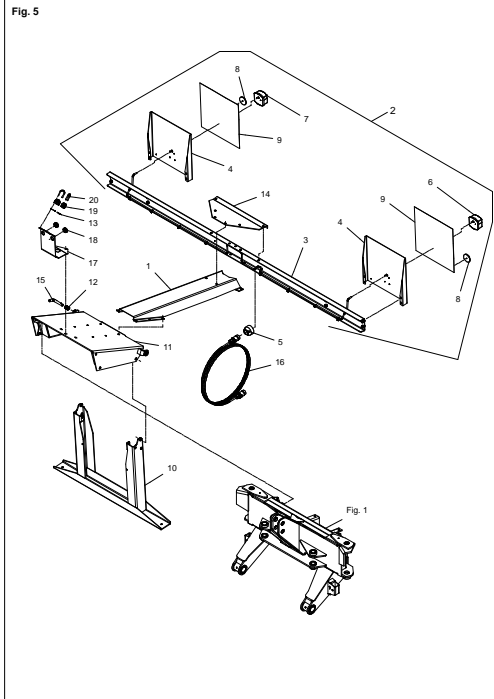

FIGURNØGLE - FIGURSCHLÜSSEL - FIGURE KEY - LISTE DE FIGURES

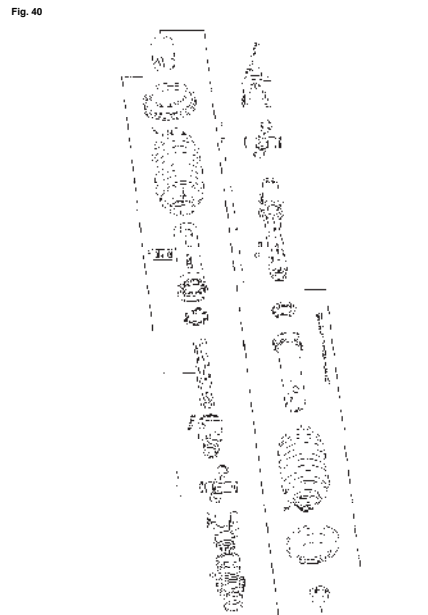
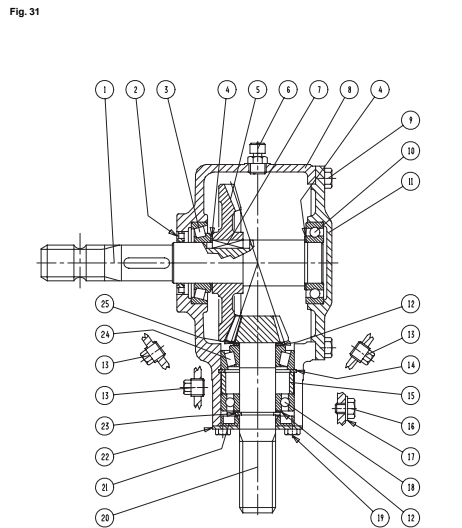
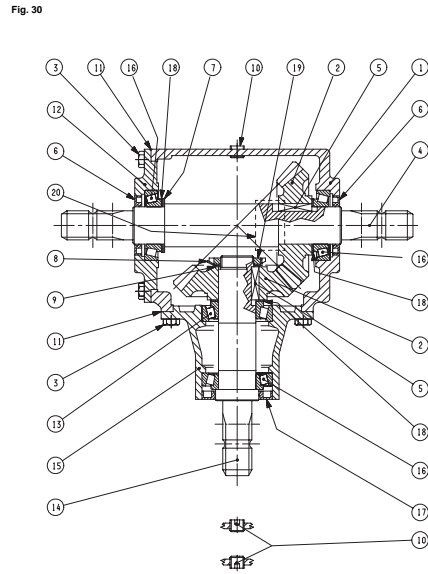
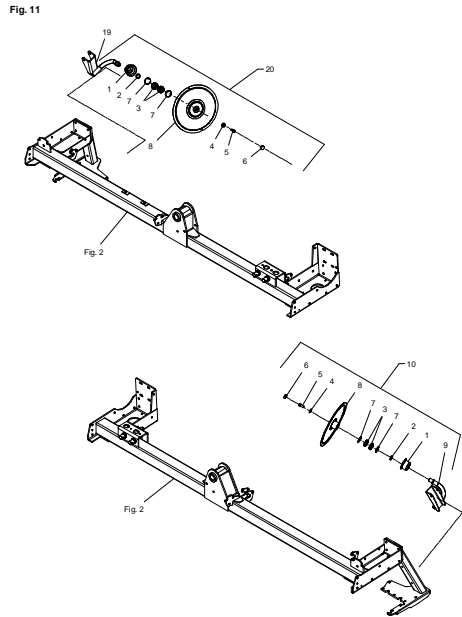

FIGURNØGLE - FIGURSCHLÜSSEL - FIGURE KEY - LISTE DE FIGURES

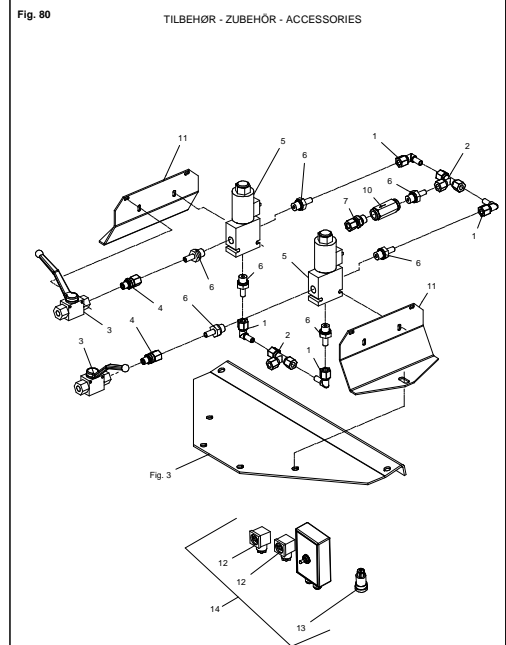
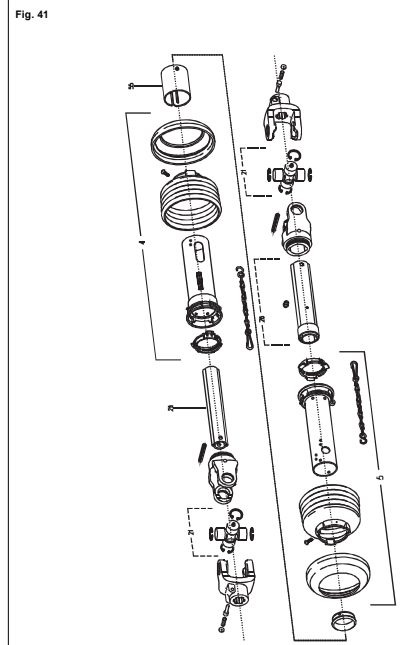
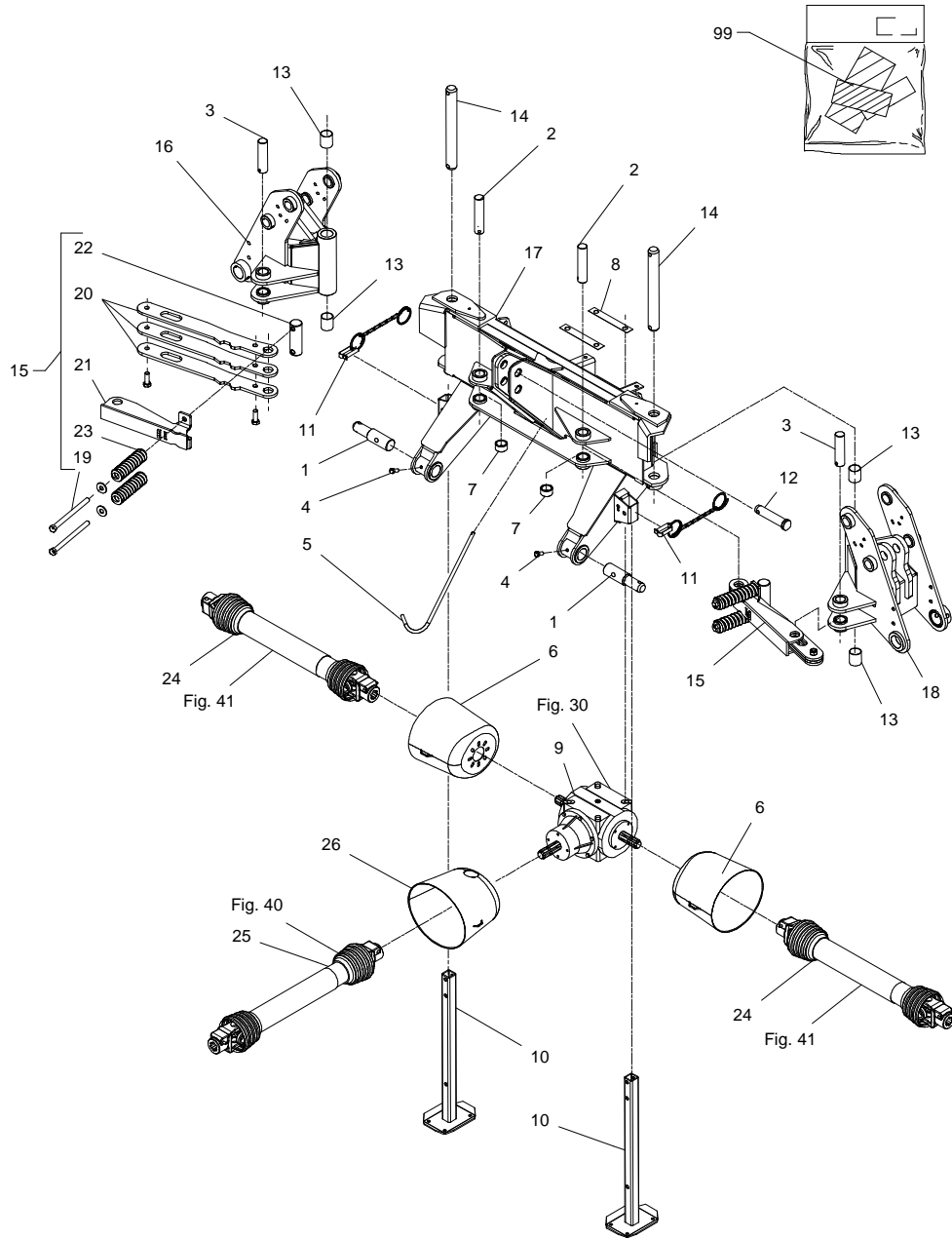

Fig. 1



GXS-0005/1 GXS 9005

FIG. 1.

>=2650101501

HERTIL, DAZU,
TO THIS, A CECI

POS.	VARENUMMER	ANTAL	BENÆVNELSE	BEZEICHNUNG	DESIGNATION		
1.	2365-090X	2	TAP KAT. 3 ZAPPEN KAT. 3		DOWEL CAT. 3		
2.	2365-094X	2	TAP ZAPPEN		DOWEL	1251-6503	1
3.	2365-093X	2	TAP ZAPPEN		DOWEL	1251-6503	1
4.	2184-229X	2	BOLT BOLZEN		BOLT	1220-4122	1
5.	2228-249X	1	BØJLE BUEGEL		RAIL	1241-3403 1251-3204	1 1
6.	2210-399X	2	PTO-SKÆRM, OVAL PTO-SCHUTZ, OVAL		PTO-GUARD, OVAL	1213-2126 1241-1304	4 4
7.	2365-198X	2	BØSNING BUCHSE		BUSH		
8.	2113-297X	2	LÅSEBLIK SPERRBLECH		COVER PLATE	1213-5324	2
9.	3113-233X	1	VINKELTRÆK, 540 RPM WINKELGETRIEBE, 540 RPM		BEVEL GEAR, 540 RPM		
10.	3365-410X	2	STØTTEBEN ABSTELLSTUETZE		JACK	1252-5501 1433-0292	1 1
11.	2365-313X	2	LÅSETAP FEDERSTECKBOLZEN		PIN LOCK		
12.	1399-0125	1	TAP KAT. 3 ZAPPEN KAT. 3		DOWEL CAT. 3		
13.	1335-4401	4	GLACIERLEJE 44-40-50 GLISSALAGER 44-40-50		BEARING GLISSA 44-40-50		
14.	2225-421A	2	TAP Ø40 L=359 SCHNÄPPER Ø40 L=359		DOWEL Ø40 L=359	1251-5505 1251-8505	2 2
15.	3365-124B	2	STENUDLØSER STEINSCHUTZ		STONE PROTECTION		
16.	3365-900X	1	DREJEKONSOL HØJRE DREHKONSOLE RECHTS		ROTARY BRACKET RIGHT		
17.	3365-073A	1	TOPRAMME TOPRAHMEN		HEADSTOCK		
18.	3365-905X	1	DREJEKONSOL VENSTRE DREHKONSOLE LINKS		ROTARY BRACKET LEFT		
19.	1214-5626	4	STÅLSKRUE M16-220 STAHLSECHSKANTSCHRAUBE M16-220		STEEL SCREW M16-220	1241-4601	1
20.	2365-120B	6	UDLØSERSTANG AUSLÖSER STANGE		RELEASE ROD	1213-5424 1220-5122 1241-4601	2 2 2
21.	3365-122A	2	ÅG YOKE		YOKE		
22.	2365-123X	2	TAP ZAPPEN		DOWEL		
23.	1431-5698	4	TRYKFJEDER DRUCKFEDER		COMPRESSION SPRING		
24.	1340-5117	2	KRAFTOVERFØRINGSAKSEL GELENKWELLE		PTO SHAFT		
25.	1340-5112	1	KRAFTOVERFØRINGSAKSEL GELENKWELLE		PTO SHAFT		
26.	2210-961X	1	PTO SKÆRM SCHUTZ FÜR GELENKWELLE		PTO GUARD	1165-0186 1213-2126 1241-1304	3 4 4
99.	3889-252X	1	TRANSFER 9005 AUFKLEBER 9005		TRANSFER 9005		

Fig. 2

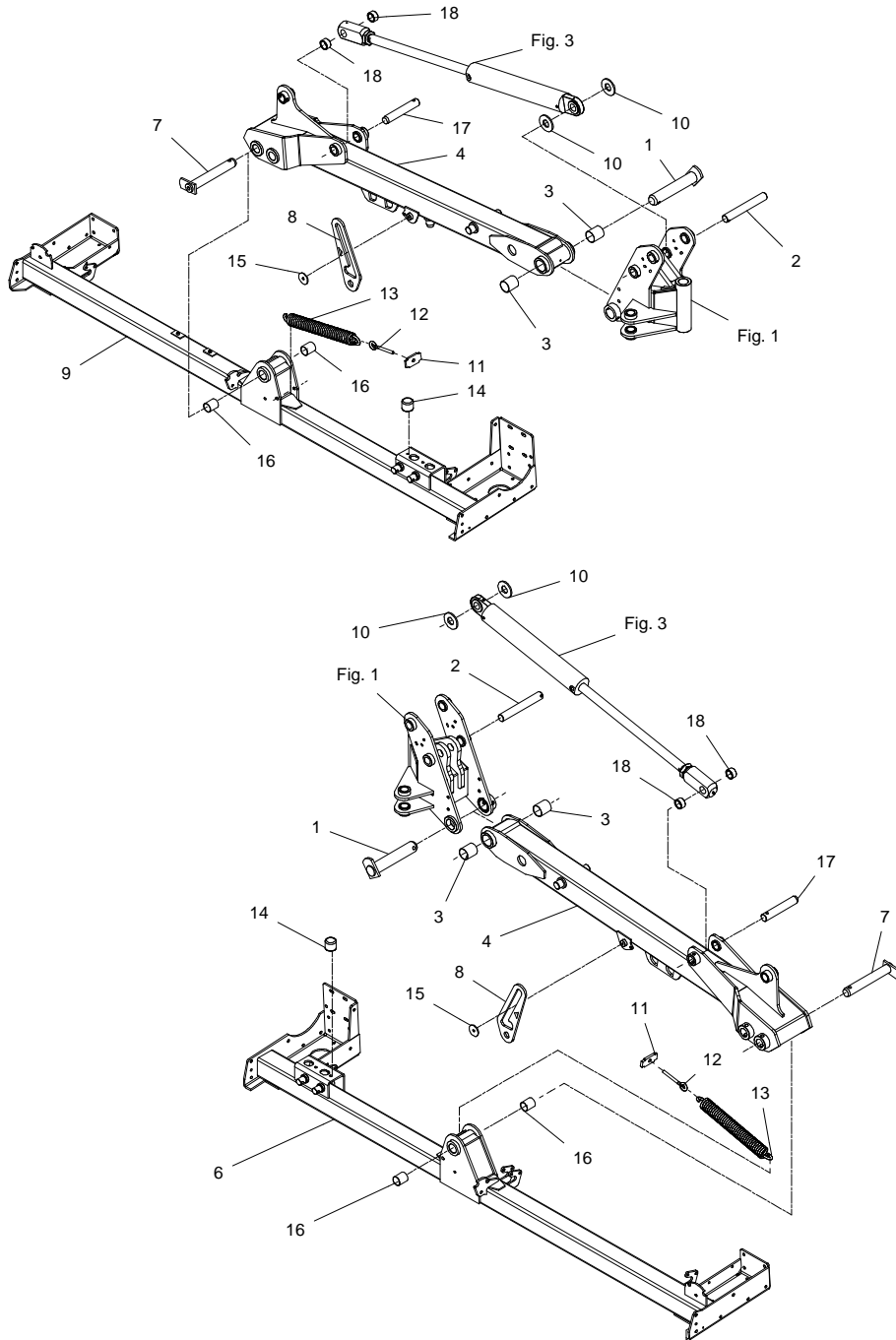

GXS-0005/1 GXS 9005

FIG. 2.

>=2650101501

HERTIL, DAZU,
TO THIS, A CECI

POS.	VARENUMMER	ANTAL	BENÆVNELSE	BEZEICHNUNG	DESIGNATION		
1.	3325-656X	2	TAP ZAPFEN		DOWEL	1251-3601 1251-5602 1251-8601	1 1 1
2.	2365-445X	2	TAP ZAPFEN		DOWEL		
3.	1335-5520	4	GLACIERLEJE 55-50-60 GLISSALAGER 55-50-60		BEARING GLISSA 55-50-60		
4.	3365-830X	2	UDLIGGER AUSLEGER		SPINNAKER		
6.	3322-124X	1	STEL RAHMEN >=2650101501 <=2650101511		FRAME	1215-3320 1220-3321	2 2
6. 1	3322-124A	1	STEL RAHMEN >=2650101612		FRAME		
7.	3321-980X	2	TAP ZAPFEN		DOWEL	1241-6702 1251-3501 1251-5503 1251-8501 1313-1101	1 1 1 1 1
8.	2365-842X	2	LÅS SCHLOSS		LOCK	1241-7601 1251-7501 1254-4201	1 1 1
9.	3322-120X	1	STEL RAHMEN >=2650101501 <=2650101511		FRAME	1213-2224 1219-0217	1 1
9. 1	3322-120A	1	STEL RAHMEN >=2650101612		FRAME		
10.	2365-625X	4	SKIVE SCHEIBE		WASHER		
11.	2365-854X	2	BESLAG BESCHLAG		SUPPORT	1214-4430 1220-4321 1241-3403	1 2 3
12.	1392-0110	2	ØTEBOLT M12-123 GALV AUGBOLZEN M12-123 GALV		EYE BOLT M12-123 GALV		
13.	1432-6698	2	TRÆKFJEDER ZUGFEDER		TENSION SPRING		
14.	1393-0110	2	GUMMIBUFFE GUMMIBUFFER		RUBBER BUFFER	1213-3224 1241-2502	1 1
15.	2365-893X	2	SKIVE SCHEIBE		WASHER	1213-3222	1
16.	1335-4401	4	GLACIERLEJE 44-40-50 GLISSALAGER 44-40-50		BEARING GLISSA 44-40-50	1241-8705 1251-5401 1251-7406	2 1 3
17.	2322-132X	2	TAP ZAPFEN		DOWEL	1251-5406 1251-7408	1 1
18.	2365-198X	4	BØSNING BUCHSE		BUSH		

Fig. 3

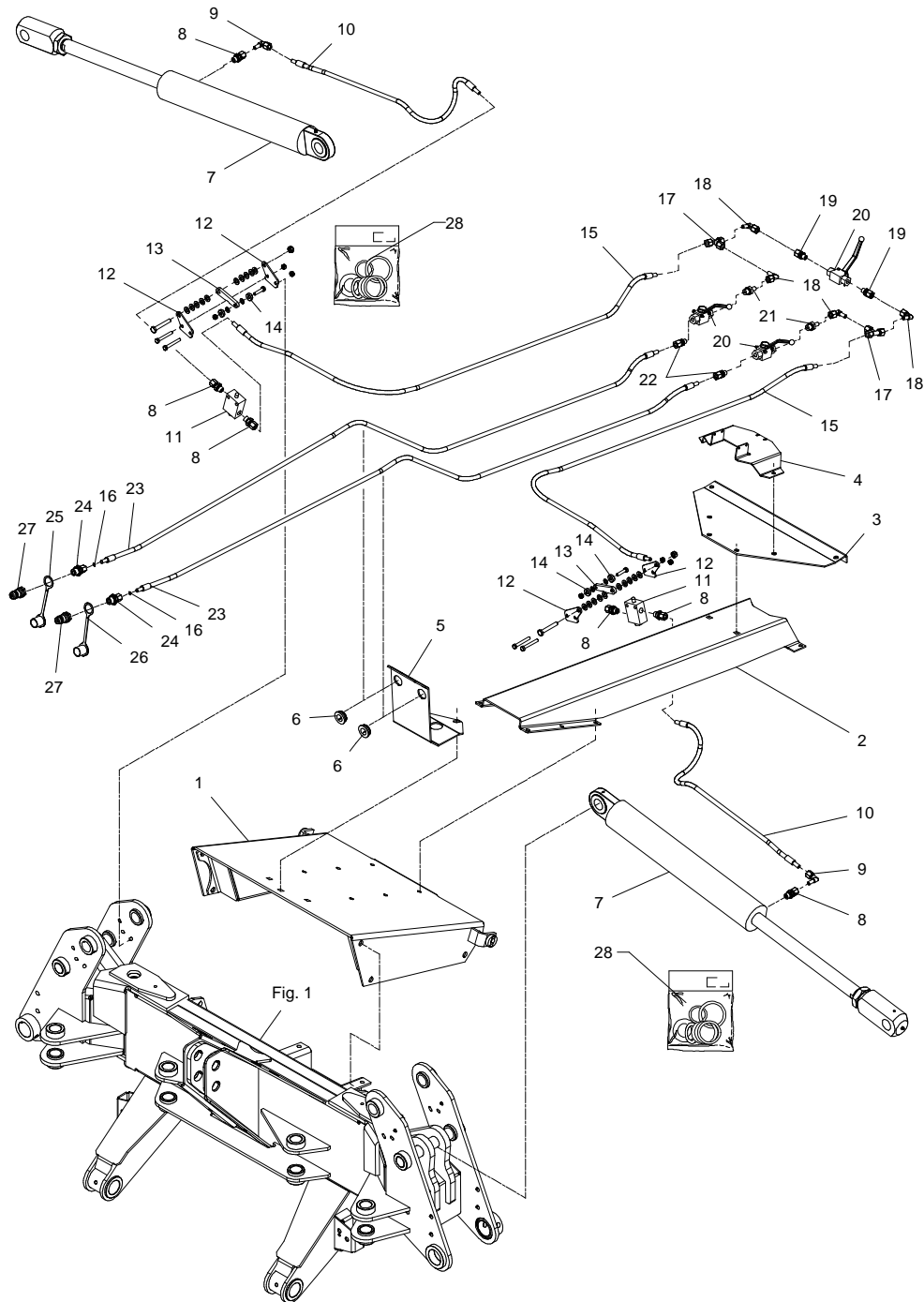

GXS-0005/1 GXS 9005

FIG. 3.

>=2650101501

POS.	VARENUMMER	ANTAL	BENÆVNELSE	BEZEICHNUNG	DESIGNATION	HERTIL, DAZU, TO THIS, A CECI
1.	3365-299X	1	KONSOL KONSOLE		BRACKET	1213-5424 4 1220-5321 4 1241-4505 4
2.	3365-398X	1	HOLDER HALTERUNG		SUPPORT	
3.	2365-399X	1	BESLAG BESCHLAG		CLAMP	1213-3224 4 1213-3322 10 1220-3321 14 1241-2401 4 1241-2502 10
4.	2365-261X	1	BESLAG BESCHLAG		CLAMP	1214-1101 6 1220-1321 6
5.	2365-414X	1	BESLAG BESCHLAG		FITTING	1213-3322 3 1220-3321 3 1220-3924 1 1241-2502 3
6.	2227-637X	2	LEJEBØSNING LAGERBUECHSE		BEARING BUSH	
7.	1317-3002	2	TRÆKCYLINDER ZUGZYLINDER		DRAWING CYLINDER	
8.	1311-8534	6	FORSKRUNING VERSCHRAUBUNG		SCREWED CONNECTION	
9.	1311-8603	2	VINKELFORSKRUNING WINKELVERSCHRAUBUNG		ANGLE COUPLING	
10.	1317-5010	2	SLANGE 1/4"-950 SCHALUCH 1/4"-950		HOSE 1/4"-950	
11.	1317-0107	2	VENTIL VENTIL		VALVE	
12.	2321-952X	4	MONTERINGSPLADE MONTIERUNGSPLATTE		MOUNTING PLATE	1214-2226 2 1214-3228 1 1220-2321 2 1220-3321 1 1241-2402 10
13.	2321-954X	2	RULLEARM ROLLEARM		ROLLER ARM	1214-2122 1 1220-2321 1 1241-1202 2
14.	1331-3107	4	KUGLELEJE KUGELLAGER		BALL BEARING	
15.	1317-0828	2	HYDRAULIKSLANGE L=1750 HYDRAULIKSLAUCH L=1750		HYDRAULIC HOSE L=1750	
16.	2320-676X	2	DYSE DUESE		NOZZLE	
17.	1311-8406	2	T-STYKKE T-STUECK		T-PIECE	
18.	1311-8603	4	VINKELFORSKRUNING WINKELVERSCHRAUBUNG		ANGLE COUPLING	
19.	1311-1416	2	RØRSTUDS ROHRSTUTZEN		PIPE STUB	
20.	1317-0725	3	KUGLEHANE 1/4" KUGELHAHN 1/4"		BALL TAP 1/4"	1214-1101 2 1220-1321 2 1241-1101 2
21.	1311-8535	2	RØRSTUDS ROHRSTUTZEN		PIPE STUB	
22.	1311-1411	2	RØRFORSKRUNING ROHRVERSCHRAUBUNG		PIPE COUPLING	
23.	1317-0880	2	HYDRAULIKSLANGE L=2300 HYDRAULIKSLAUCH L=2300		HYDRAULIC HOSE L=2300	
24.	1311-1409	2	RØRFORSKRUNING ROHRVERSCHRAUBUNG		PIPE COUPLING	

Fig. 3

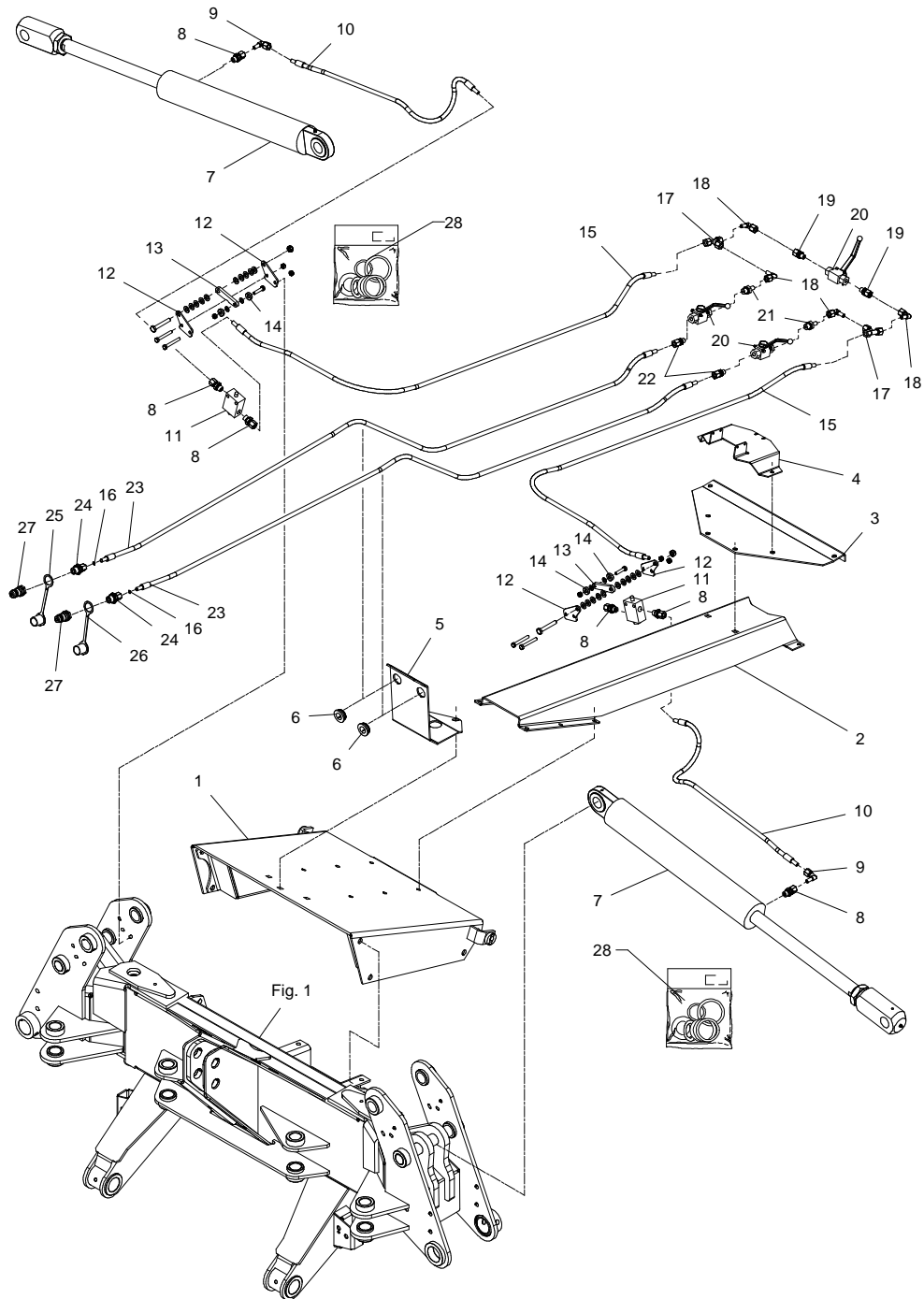

GXS-0005/1 GXS 9005

FIG. 3.

>=2650101501

HERTIL, DAZU,
TO THIS, A CECI

POS.	VARENUMMER	ANTAL	BENÆVNELSE	BEZEICHNUNG	DESIGNATION
25.	1393-0138	1	BESKYTTELSESHÆTTE GUL SCHUTZKAPPE GELB		PROTECTION CAP YELLOW
26.	1393-0139	1	BESKYTTELSESHÆTTE RØD SCHUTZKAPPE ROT		PROTECTION CAP RED
27.	1317-0302	2	STIK F/LYNKOBLING ANSCHLUSS F/SCHNELLKUPPLUNG		CONNECTION F/QUICK-COUPLING
28.	1317-9831	2	PAKNINGSSÆT DICHTUNGSSATZ		SET OF GASKETS

Fig. 4

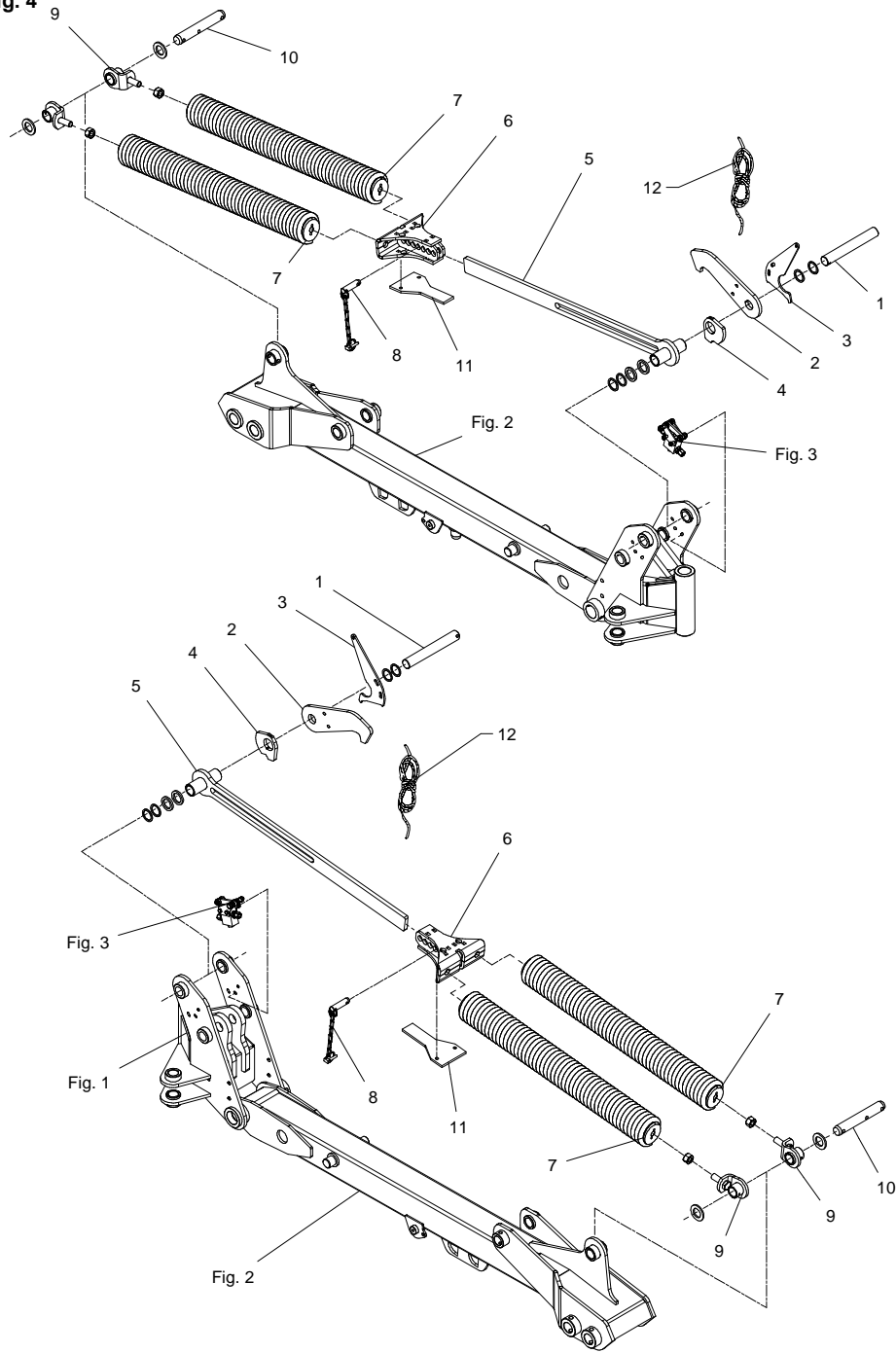

GXS-0005/1 GXS 9005

FIG. 4.

>=2650101501

HERTIL, DAZU,
TO THIS, A CECI

POS.	VARENUMMER	ANTAL	BENÆVNELSE	BEZICHTUNG	DESIGNATION		
1.	2365-445X	2	TAP ZAPFEN		DOWEL		
2.	2365-825X	2	KROG HAGEN		HOOK	1241-7802 1241-8907	3 2
3.	2365-823X	2	UDLØSER AUSLØSER		RELEASE	1215-3320 1220-3321	2 2
4.	2321-866X	2	KURVESTYR FØHRINGSPLATTE		STEERING PLATE	1213-2224 1219-0217	1 1
5.	3365-870X	2	FJEDER TRÆKSTANG FEDER ZUGSTANGE		SPRING DRAWBAR	1313-1101	1
6.	3365-873X	2	FJEDERBESLAG FEDERBESCHLAG		SPRING BRACKET		
7.	3365-157X	4	TRÆKFJEDER KPL ZUGFEDER KPL		TENSION SPRING CPL	1213-6422	1
8.	3365-876X	2	TAP ZAPFEN		DOWEL		
9.	3365-877X	4	FJEDERHOLDER FEDERHALTER		SPRING SUPPORT	1220-6122 1313-1101	1 1
10.	2321-979X	2	TAP ZAPFEN		DOWEL	1241-8705 1251-5401 1251-7406	2 1 1
11.	2365-824X	2	GLIDEPLADE GLEITPLATTE		SLIDEPLATE	1215-3320 1220-3321 1241-2401	2 2 2
12.	2365-403X	2	SNOR SEIL		STRING		

Fig. 5

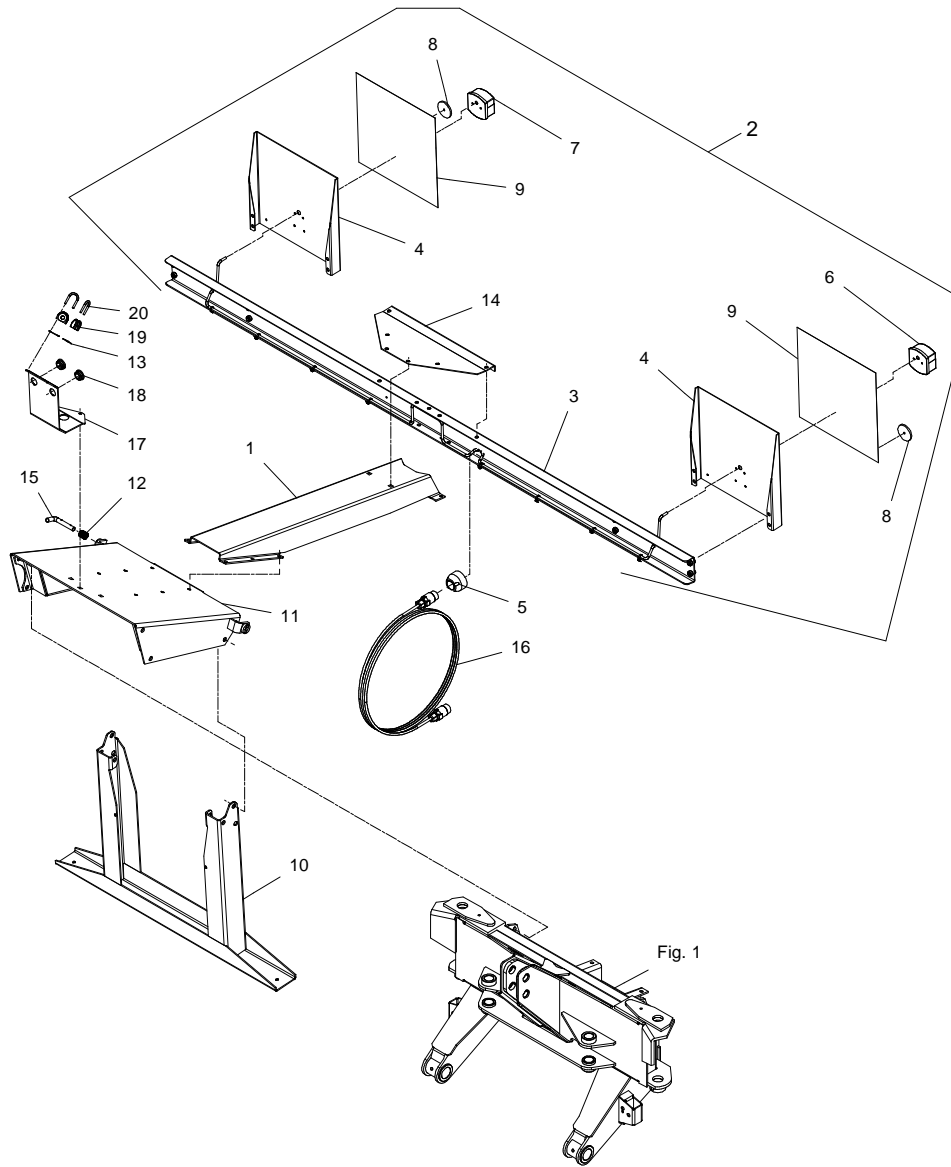

GXS-0005/1 GXS 9005

FIG. 5.

>=2650101501

HERTIL, DAZU,
TO THIS, A CECI

POS.	VARENUMMER	ANTAL	BENÆVNELSE	BEZEICHNUNG	DESIGNATION		
1.	3365-398X	1	HOLDER HALTERUNG	SUPPORT			
2.	3365-088X	1	BOM AUSLEGER	BAR			
3.	2365-083X	1	SKINNE SCHIENE	RAIL		1165-0130	8
4.	2365-134X	2	PLADE FOR ADVARSELSTAVLE PLATTE FUER WARNTAFEL	PLATE FOR WARNING BOARD		1213-4222 1220-4321	4 4
5.	1391-0711	1	7-POLET STIKDÅSE 7-POL STECKDOSE	PLUG BOX 7-POLES		1216-1324 1220-1322 1241-1203	3 3 3
6.	1391-0917	1	BAGLYGTE, VENSTRE RUECKLICHT, LINKE	REAR LIGHT, LEFT		1216-1156 1220-1322 1241-1203	2 2 2
7.	1391-0916	1	BAGLYGTE, HØJRE RUECKLICHT, RECHTE	REAR LIGHT, RIGHT		1216-1156 1220-1322 1241-1203	2 2 2
8.	1391-0600	2	REFLEX RØD RUECKSTRAHLER ROT	REFLECTION RED			
9.	PR80-6604	2	SELVKLEBENDE ADVARSELSFOLIE SELBSTKLEBENDE WARNFOLIE	SELF-ADHESIVE WARNING FOIL			
10.	3365-295X	1	STØTTEBEN ABSTELLSTUETZE	JACK		1213-5324 1220-5321 1241-4505	4 4 4
11.	3365-299X	1	KONSOL KONSOLE	BRACKET		1213-5424 1220-5321 1241-4505	4 4 4
12.	1431-3298	2	TRYKFJEDER DRUCKFEDER	COMPRESSION SPRING			
13.	2365-404X	2	UNDERLAG ZWISCHENLAGE	INTERMEDIATE PLATE			
14.	2365-399X	1	BESLAG BESCHLAG	CLAMP		1213-3322 1220-3321 1241-2502	5 5 5
15.	2365-396X	1	TAP SCHNÄPPER	DOWEL		1241-4304 1251-3204	1 2
16.	3365-227X	1	TRAILERLEDNING, 4 M ANHAENGER LEITUNG, 4 M	TARILER CABLE, 4 M			
17.	2365-414X	1	BESLAG BESCHLAG	FITTING		1213-3322 1220-3321 1220-3924 1241-2502	2 2 1 1
18.	2227-637X	2	LEJEBØSNING LAGERBUECHSE	BEARING BUSH			
19.	2365-366X	2	PORCELÆNSØJE PORZELAN OESE	PORCELAIN EYE			
20.	2365-367X	2	BØJLESKRUE SCHRAUBE	SCREW			

Fig. 6

HØJRE - RIGHT - RECHTE

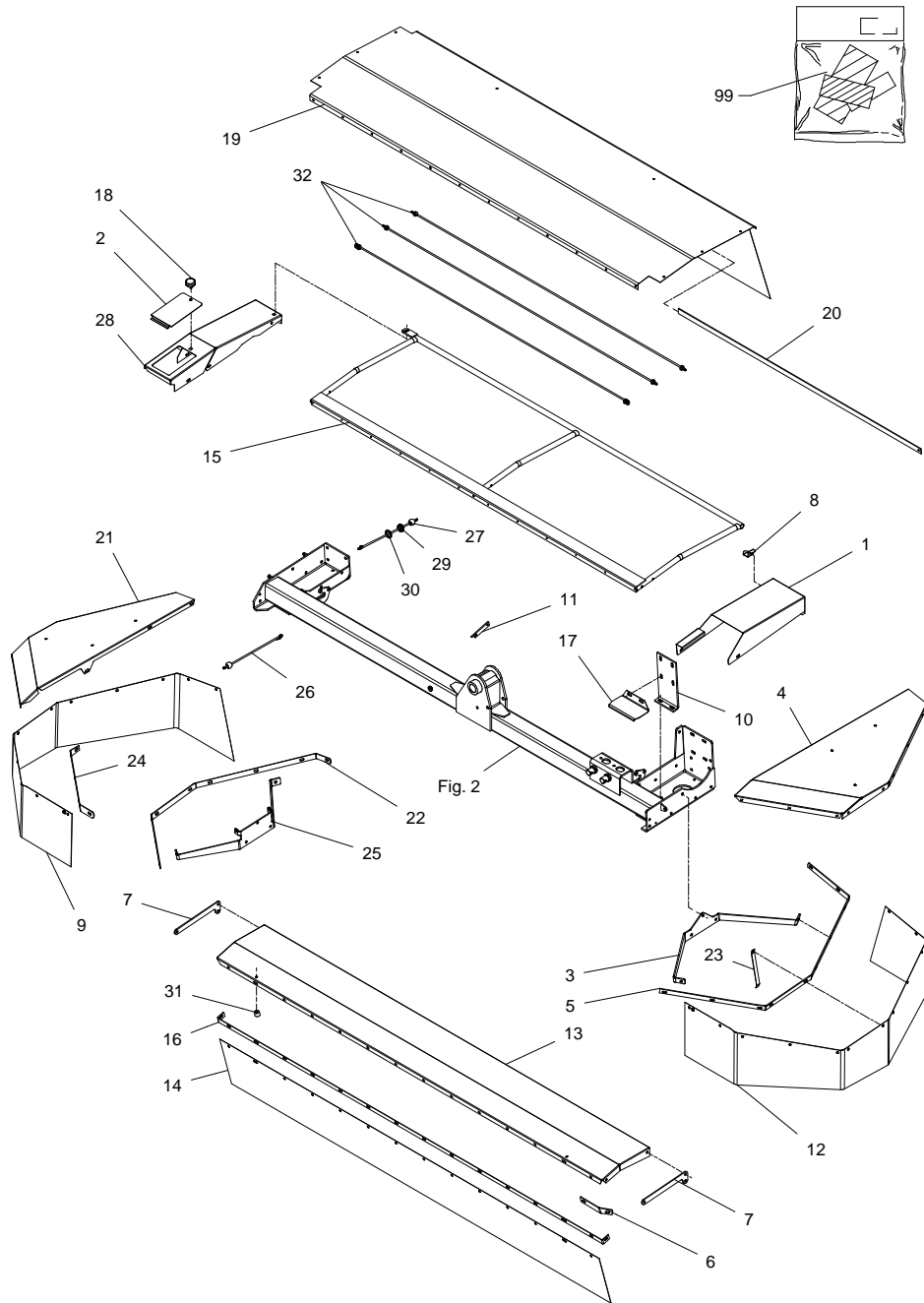

GXS-0005/1 GXS 9005

FIG. 6.

>=2650101501 <=2650101511

HERTIL, DAZU,
TO THIS, A CECI

POS.	VARENUMMER	ANTAL	BENÆVNELSE	BEZEICHNUNG	DESIGNATION		
1.	2087-850X	1	SKÆRM SCHUTZ		GUARD	1213-3322	1
						1213-4322	2
						1220-3321	1
						1220-4321	2
						1241-2502	2
						1241-3403	4
2.	2325-336X	1	DÆKSEL DECKEL		COVER	1219-0404	1
						1241-2404	1
3.	2087-852X	1	SKÆRMBÆRER SCHIRMTREAGER		GUARD HOLDER		
4.	2087-833X	1	SKÆRM, VENSTRE SCHUTZ, LINKE		GUARD, LEFT	1213-4322	3
						1220-4321	3
						1241-2505	6
5.	2087-851X	1	SKINNE SCHIENE		RAIL		
6.	2087-856X	1	BESLAG BESCHLAG		PLATE		
7.	2087-854X	2	BESLAG BESCHLAG		PLATE	1213-3322	3
						1220-3321	3
						1241-2502	6
8.	2325-603X	1	BESLAG BESCHLAG		CLAMP	1215-2222	1
						1220-2321	1
						1241-2502	1
9.	2087-860X	1	DUG, HØJRE TUCH, RECHTE		CANVAS, RIGHT	1215-3226	3
						1215-3228	7
						1220-3321	10
						1241-2502	8
10.	2325-628X	1	STIVER STUETZE		SUPPORT	1213-4224	4
						1213-4327	2
						1241-3403	8
11.	2325-335X	1	STOP STOP		STOP	1214-2126	1
						1220-2321	1
						1241-1202	1
12.	2087-858X	1	DUG, VENSTRE TUCH, LINKE		CANVAS, LEFT	1215-3226	3
						1215-3228	6
						1220-3321	9
						1241-2502	7
13.	2087-843X	1	FORSKÆRM SCHUTZ, FORDERE		GUARD, FRONT		
14.	2087-859X	1	DUG, FORRESTE TUCH, VORDERE		CANVAS, FRONT	1215-3226	4
						1215-3228	13
						1220-3321	17
						1241-2502	17
15.	3325-595X	1	BØJLE BUEGEL		HOOP	1213-3322	1
						1213-3622	3
						1213-4622	3
						1220-3122	3
						1220-3321	3
						1220-4321	3
						1241-2404	1
						1393-0105	2
16.	2087-846X	1	SKINNE SCHIENE		RAIL	1213-3322	3
						1220-3321	3
						1241-2502	6
17.	2087-794X	1	SKÆRM ABSCHIRMUNG		GUARD		
18.	1393-0186	1	GUMMIBUFFE GUMMIPUFFER		RUBBER BUFFER		
19.	2320-844X	1	DUG TUCH		CANVAS	1219-0599	12
						1241-1206	12

Fig. 6

HØJRE - RIGHT - RECHTE

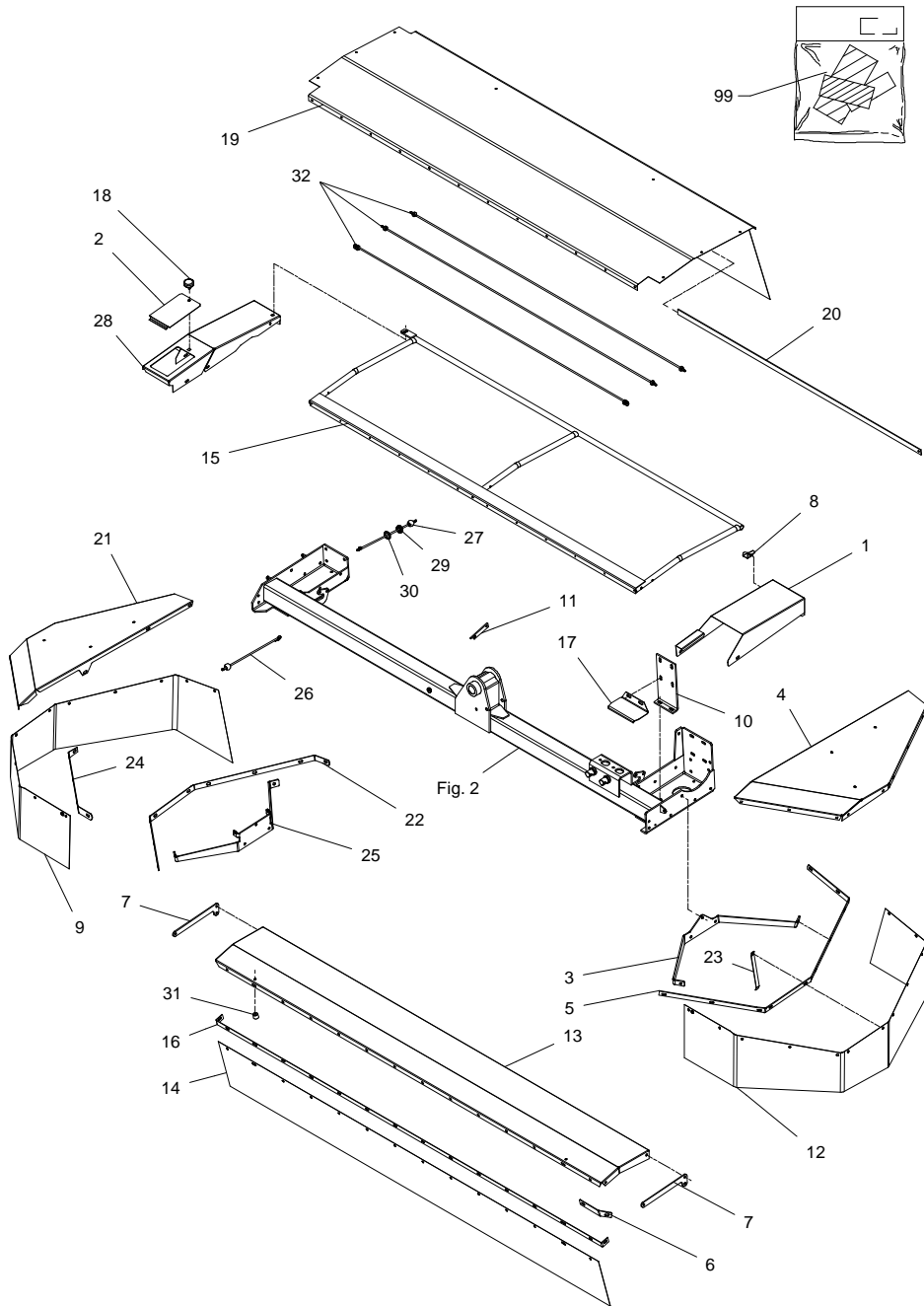

GXS-0005/1 GXS 9005

FIG. 6.

>=2650101501 <=2650101511

HERTIL, DAZU,
TO THIS, A CECI

POS.	VARENUMMER	ANTAL	BENÆVNELSE	BEZEICHNUNG	DESIGNATION		
20.	2228-791X	1	SKINNE SCHIENE		RAIL	1213-2224 1241-1304	1 2
21.	2087-844X	1	SKÆRM, HØJRE SCHUTZ, RECHTE		GUARD, RIGHT	1213-4322 1220-4321 1241-2505	3 3 3
22.	2365-242X	1	SKINNE SCHIENE		RAIL		
23.	2223-576X	1	HOLDER HALTER		HOLDER		
24.	2365-240X	1	SKINNE SCHIENE		RAIL		
25.	2365-142X	1	SKÆRMHOLDER, HØJRE SCHUTZHALTER, RECHTE		GUARD HOLDER, RIGHT		
26.	3365-259X	1	STROP RIEMEN		STRAP		
27.	3365-260X	1	STROP RIEMEN		STRAP		
28.	2365-245X	1	SKÆRM SCHUTZ		GUARD	1220-3922 1241-1304	1 3
29.	2227-637X	1	LEJEBØSNING LAGERBUCHSE		BEARING BUSH	1241-6702	1
30.	1241-6702	1	SPÆNDESKIVE 29-42-5 SCHEIBE 29-42-5		WASHER 29-42-5		
31.	2114-175X	1	BØSNING BUCHSE		BUSH	1214-3122 1220-3321	1 1
32.	3325-291X	3	STROP STROPP		STRAP	1213-2222 1220-2321 1241-1304	2 2 6
99.	3889-298X	1	TRANSFER GXS 9005 AUFKLEBER GXS 9005		TRANSFER GXS 9005		

Fig. 6.1

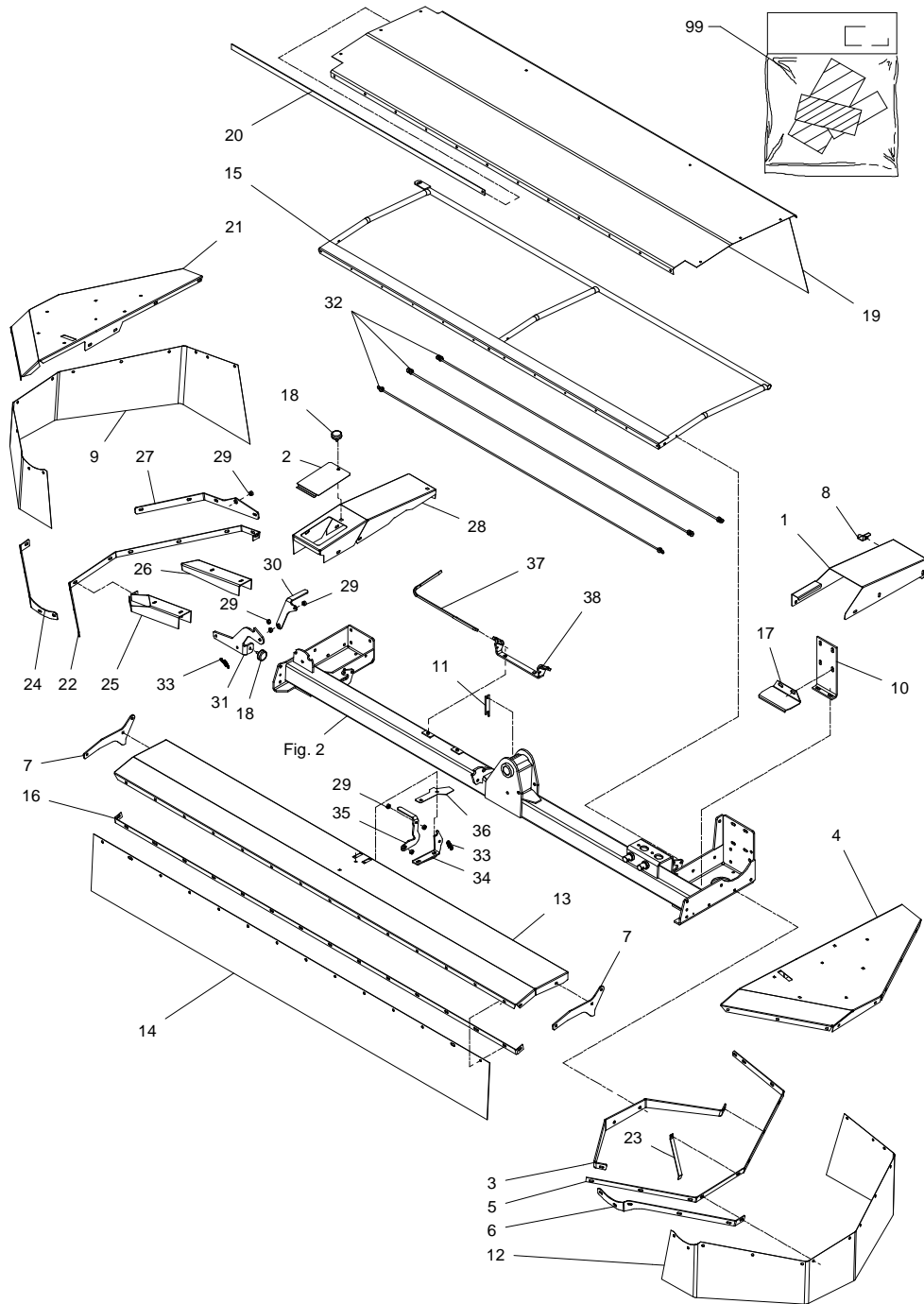

GXS-0005/1 GXS 9005

FIG. 6. 1

>=2650101612

POS.	VARENUMMER	ANTAL	BENÆVNELSE	BEZEICHNUNG	DESIGNATION	HERTIL, DAZU, TO THIS, A CECI
1.	2087-850X	1	SKÆRM SCHUTZ	GUARD	1213-3322	1
					1213-4322	2
					1220-3321	1
					1220-4321	2
					1241-2502	2
1241-3403	4					
2.	2325-336X	1	DÆKSEL DECKEL	COVER	1241-2404	1
3.	2087-852A	1	SKÆRMBÆRER SCHIRMTREAGER	GUARD HOLDER		
4.	2087-833A	1	SKÆRM, VENSTRE SCHUTZ, LINKE	GUARD, LEFT	1213-4322	3
					1220-4321	3
					1241-2505	6
5.	2087-851X	1	SKINNE SCHIENE	RAIL		
6.	2322-237X	1	SKINNE F. SIDESKÆRM SCHIENE F. SEITENSCHUTZ	RAIL F. SIDE GUARD		
7.	2322-240X	2	HÆNGSEL SCHARNIER	HINGE	1213-3322	3
					1220-3321	3
					1241-2502	6
8.	2325-603X	1	BESLAG BESCHLAG	CLAMP	1215-2222	1
					1220-2321	1
					1241-2502	1
9.	2322-245X	1	DUG TUCH	CANVAS	1215-3226	3
					1215-3228	7
					1220-3321	10
					1241-2502	8
10.	2325-628X	1	STIVER STÜTZE	SUPPORT	1213-4224	4
					1213-4327	2
					1241-3403	8
11.	2325-335X	1	STOP STOP	STOP	1214-2126	1
					1220-2321	1
					1241-1202	1
12.	2322-246X	1	DUG TUCH	CANVAS	1215-3226	3
					1215-3228	6
					1220-3321	9
					1241-2502	7
13.	2087-843A	1	FORSKÆRM SCHUTZ, FORDERE	GUARD, FRONT		
14.	2087-859A	1	DUG, FORRESTE TUCH, VORDERE	CANVAS, FRONT	1215-3226	4
					1215-3228	13
					1220-3321	17
					1241-2502	17
15.	3325-595X	1	BØJLE BUEGEL	HOOP	1213-3322	1
					1213-3622	3
					1213-4622	3
					1220-3122	3
					1220-3321	3
					1220-4321	3
					1241-2404	1
					1393-0105	2
16.	2087-846X	1	SKINNE SCHIENE	RAIL	1213-3322	3
					1220-3321	3
					1241-2502	6
17.	2087-794X	1	SKÆRM ABSCHIRMUNG	GUARD		
18.	1393-0186	2	GUMMIBUFFE GUMMIPUFFER	RUBBER BUFFER		
19.	2320-844A	1	DUG TUCH	CANVAS	1219-0599	12
					1241-1206	12

Fig. 6.1

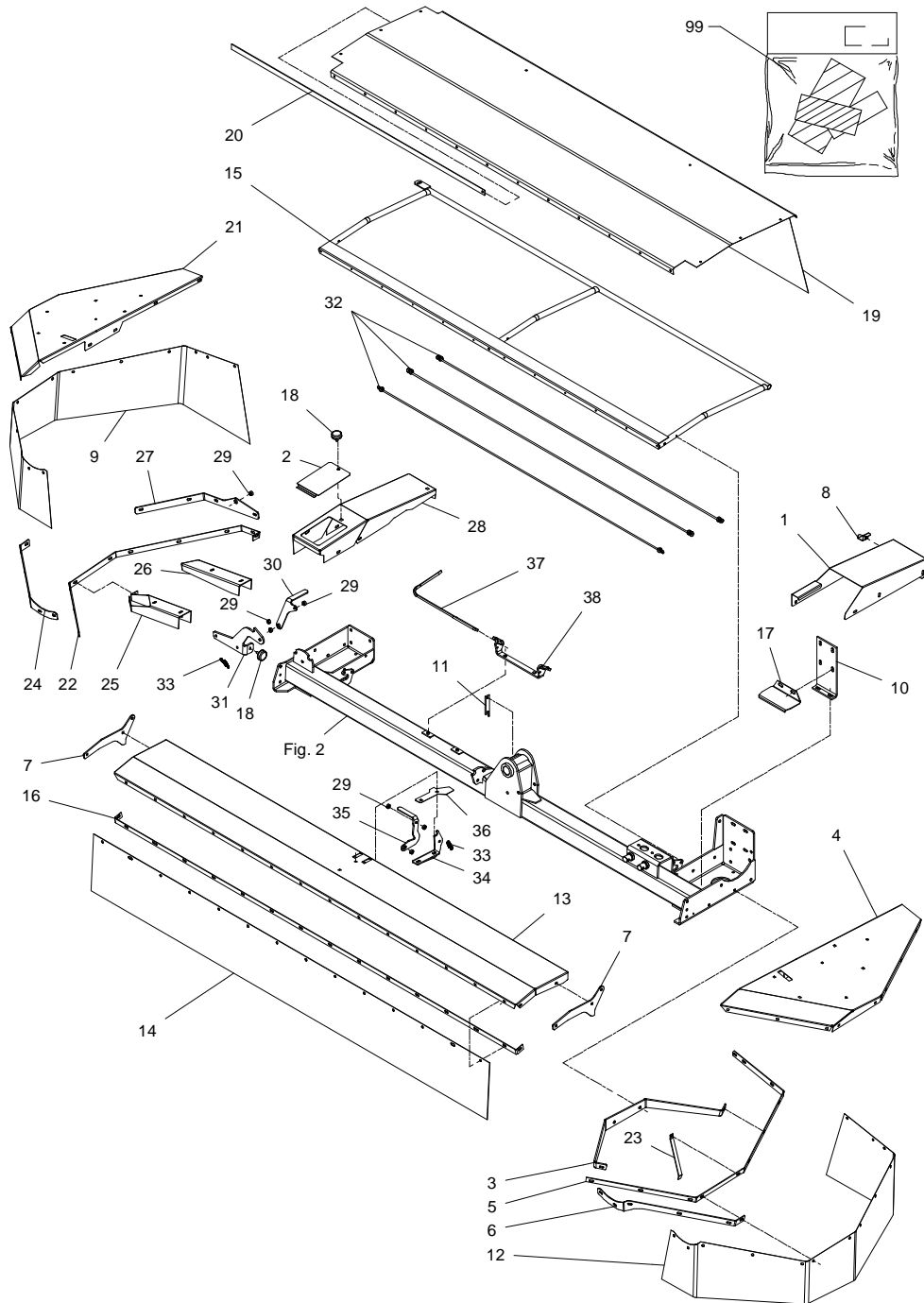

GXS-0005/1 GXS 9005

FIG. 6. 1

>=2650101612

HERTIL, DAZU,
TO THIS, A CECI

POS.	VARENUMMER	ANTAL	BENÆVNELSE	BEZEICHNUNG	DESIGNATION		
20.	2228-791X	1	SKINNE SCHIENE		RAIL	1213-2224 1241-1304	1 2
21.	2087-844A	1	SKÆRM, HØJRE SCHUTZ, RECHTE		GUARD, RIGHT	1213-4322 1220-4321 1241-2505	3 3 3
22.	2365-242A	1	SKINNE SCHIENE		RAIL		
23.	2223-576X	1	HOLDER HALTER		HOLDER		
24.	2322-236X	1	HOLDER HALTER		SUPPORT		
25.	2322-145X	1	KONSOL KONSOLE		BRACKET		
26.	2322-146X	1	KONSOL KONSOLE		BRACKET		
27.	2321-641X	1	HÆNGSEL SCHARNIER		HINGE		
28.	2322-143X	1	SKÆRM SCHUTZ		GUARD	1220-3922 1241-1304	1 3
29.	2322-243X	7	BØSNING BUCHSE		BUSH	1241-6702	1
30.	2322-238X	1	LÅS SCHLOSS		LOCK		
31.	2322-144X	1	HÆNGSEL SCHARNIER		HINGE	1214-3122 1220-3321	1 1
32.	3325-291X	3	STROP STROPP		STRAP	1213-2222 1220-2321 1241-1304	2 2 6
33.	1432-2297	2	TRÆKFJEDER ZUGFEDER		TENSION SPRING		
34.	2322-234X	1	HÆNGSEL SCHARNIER		HINGE		
35.	2322-235X	1	LÅS SCHLOSS		LOCK		
36.	2322-239X	1	SKÆRM SCHUTZ		GUARD		
37.	2083-706B	1	VÆRKTØJ WERKZEUG		TOOL		
38.	2322-227X	1	HOLDER HALTER		SUPPORT		
99.	3889-298X	1	TRANSFER GXS 9005 AUFKLEBER GXS 9005		TRANSFER GXS 9005		

Fig. 7

VENSTRE - LEFT - LINKE

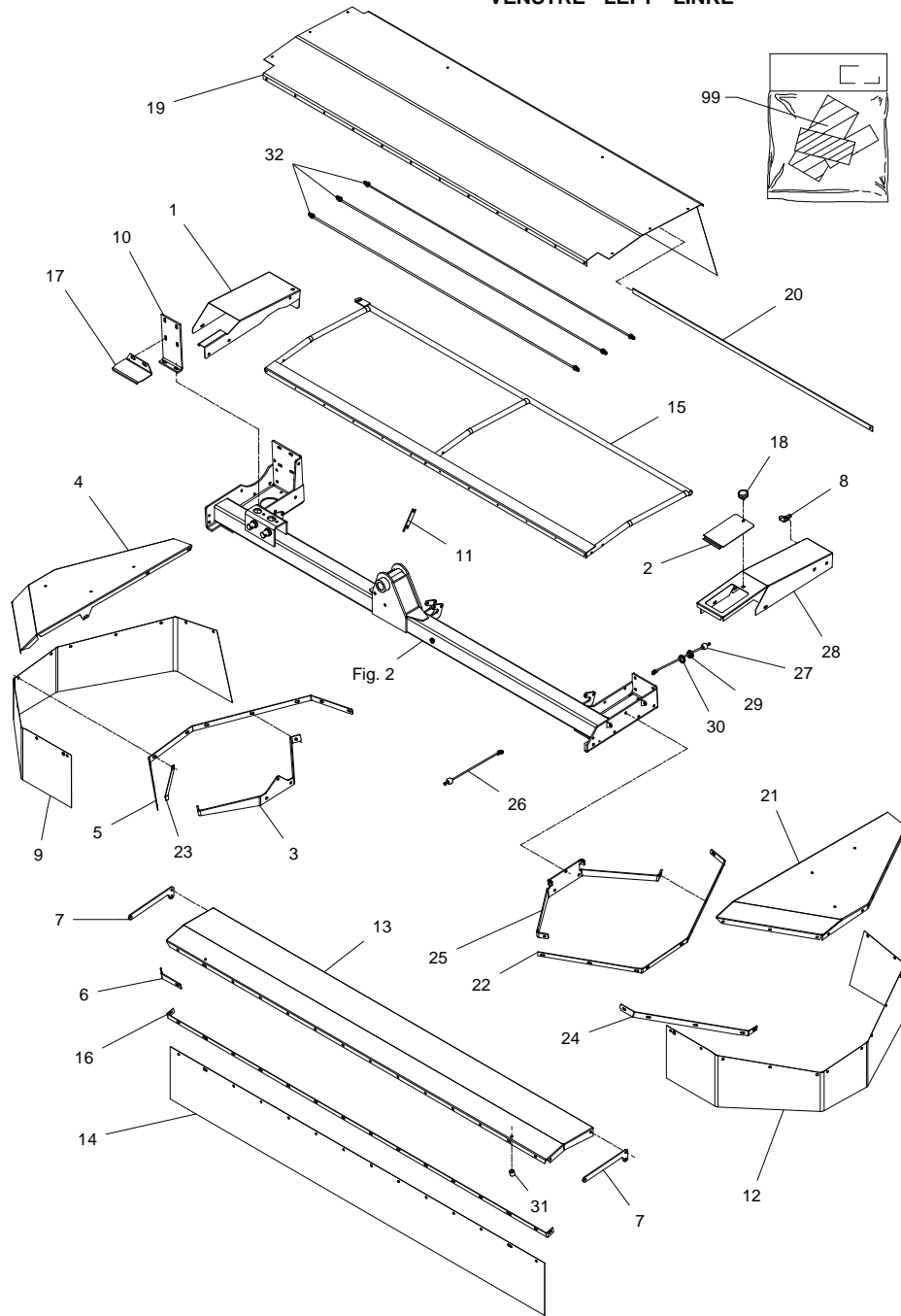

GXS-0005/1 GXS 9005

FIG. 7.

>=2650101501 <=2650101511

POS.	VARENUMMER	ANTAL	BENÆVNELSE	BEZEICHNUNG	DESIGNATION	HERTIL, DAZU, TO THIS, A CECI
1.	2365-132X	1	SKÆRM SCHUTZ	GUARD	1213-3322	1
					1213-4322	2
					1220-3321	1
					1220-4321	2
					1241-2502	2
1241-3403	4					
2.	2325-336X	1	DÆKSEL DECKEL	COVER	1219-0404	1
1241-2404	1					
3.	2087-853X	1	SKÆRMBERER STUETZE	SUPPORT		
4.	2087-844X	1	SKÆRM, HØJRE SCHUTZ, RECHTE	GUARD, RIGHT	1213-4322	3
					1220-4321	3
					1241-2505	6
5.	2087-855X	1	SKINNE SCHIENE	RAIL		
6.	2087-857X	1	BESLAG BESCHLAG	PLATE		
7.	2087-854X	2	BESLAG BESCHLAG	PLATE	1213-3322	3
					1220-3321	3
					1241-2502	6
8.	2325-603X	1	BESLAG BESCHLAG	CLAMP	1215-2222	1
					1220-2321	1
					1241-2502	1
9.	2087-860X	1	DUG, HØJRE TUCH, RECHTE	CANVAS, RIGHT	1215-3226	3
					1215-3228	7
					1220-3321	10
					1241-2502	8
10.	2325-628X	1	STIVER STUETZE	SUPPORT	1213-4224	4
					1213-4327	2
					1241-3403	8
11.	2325-335X	1	STOP STOP	STOP	1214-2126	1
					1220-2321	1
					1241-1202	1
12.	2087-858X	1	DUG, VENSTRE TUCH, LINKE	CANVAS, LEFT	1215-3226	3
					1215-3228	6
					1220-3321	9
					1241-2502	7
13.	2087-843X	1	FORSKÆRM SCHUTZ, FORDERE	GUARD, FRONT		
14.	2087-859X	1	DUG, FORRESTE TUCH, VORDERE	CANVAS, FRONT	1215-3226	4
					1215-3228	13
					1220-3321	17
					1241-2502	17
15.	3325-595X	1	BØJLE BUEGEL	HOOP	1213-3322	1
					1213-3622	3
					1213-4622	3
					1220-3122	3
					1220-3321	3
					1220-4321	3
					1241-2404	1
					1393-0105	2
16.	2087-846X	1	SKINNE SCHIENE	RAIL	1213-3322	3
					1220-3321	3
					1241-2502	6
17.	2087-794X	1	SKÆRM ABSCHIRMUNG	GUARD		
18.	1393-0186	1	GUMMIBUFFE GUMMIPUFFER	RUBBER BUFFER		
19.	2320-844X	1	DUG TUCH	CANVAS	1219-0599	12
					1241-1206	12

Fig. 7

VENSTRE - LEFT - LINKE

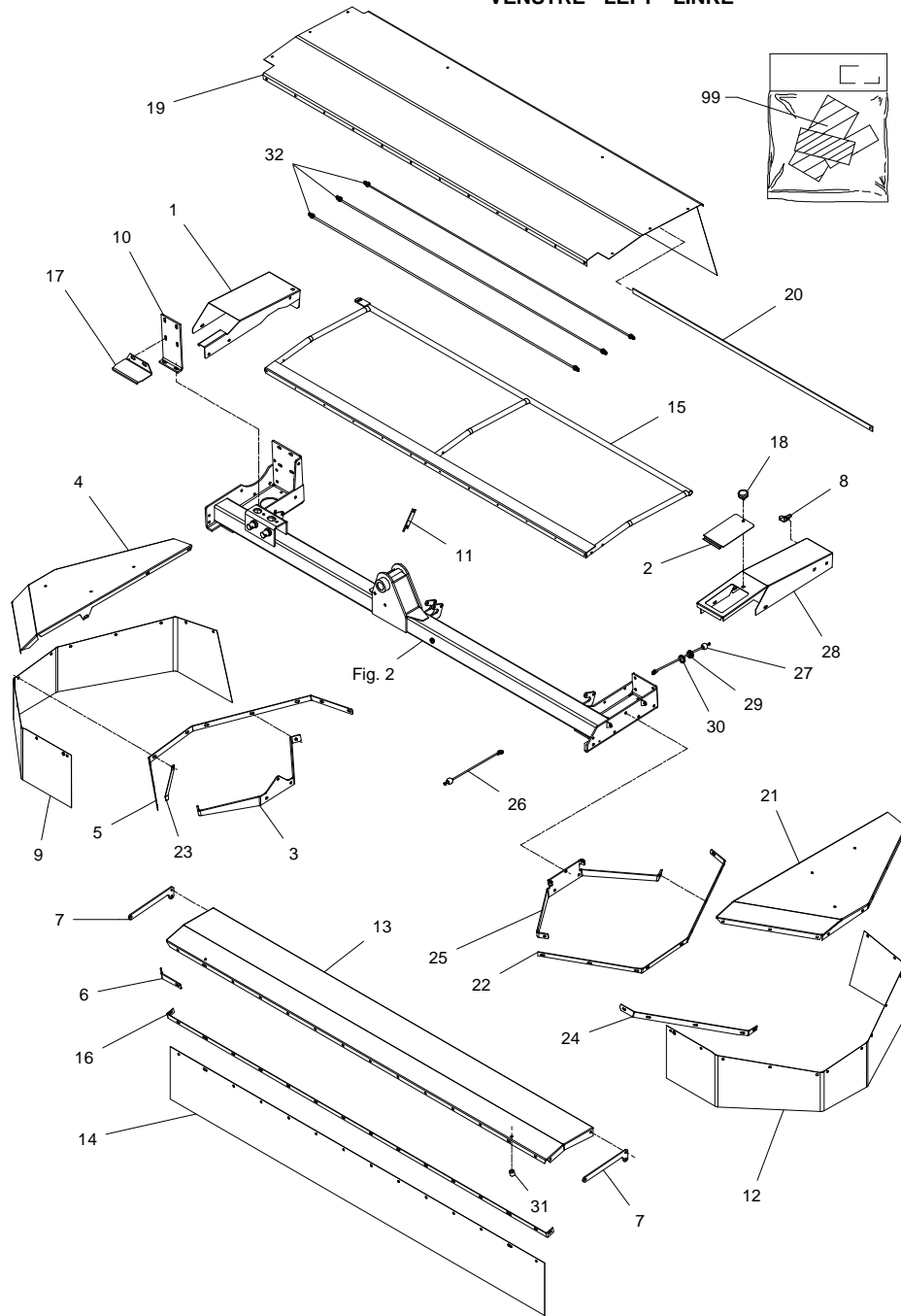

GXS-0005/1 GXS 9005

FIG. 7.

>=2650101501 <=2650101511

HERTIL, DAZU,
TO THIS, A CECI

POS.	VARENUMMER	ANTAL	BENÆVNELSE	BEZEICHNUNG	DESIGNATION		
20.	2228-791X	1	SKINNE SCHIENE	RAIL		1213-2224 1241-1304	1 2
21.	2087-833X	1	SKÆRM, VENSTRE SCHUTZ, LINKE	GUARD, LEFT		1213-4322 1220-4321 1241-2505	3 3 3
22.	2365-241X	1	SKINNE SCHIENE	RAIL			
23.	2223-576X	1	HOLDER HALTER	HOLDER			
24.	2365-239X	1	SKINNE SCHIENE	RAIL			
25.	2365-144X	1	SKÆRMHOLDER, VENSTRE SCHUTZHÄLTER, LINKE	GUARD HOLDER, LEFT			
26.	3365-259X	1	STROP RIEMEN	STRAP			
27.	3365-260X	1	STROP RIEMEN	STRAP			
28.	2365-133X	1	SKÆRM SCHUTZ	GUARD		1220-3922 1241-1304	1 3
29.	2227-637X	1	LEJEBØSNING LAGERBUCHSE	BEARING BUSH		1241-6702	1
30.	1241-6702	1	SPÆNDESKIVE 29-42-5 SCHEIBE 29-42-5	WASHER 29-42-5			
31.	2114-175X	1	BØSNING BUCHSE	BUSH		1214-3122 1220-3321	1 1
32.	3325-291X	3	STROP STROPP	STRAP		1213-2222 1220-2321 1241-1304	2 2 6
99.	3889-298X	1	TRANSFER GXS 9005 AUFKLEBER GXS 9005	TRANSFER GXS 9005			

Fig. 7.1

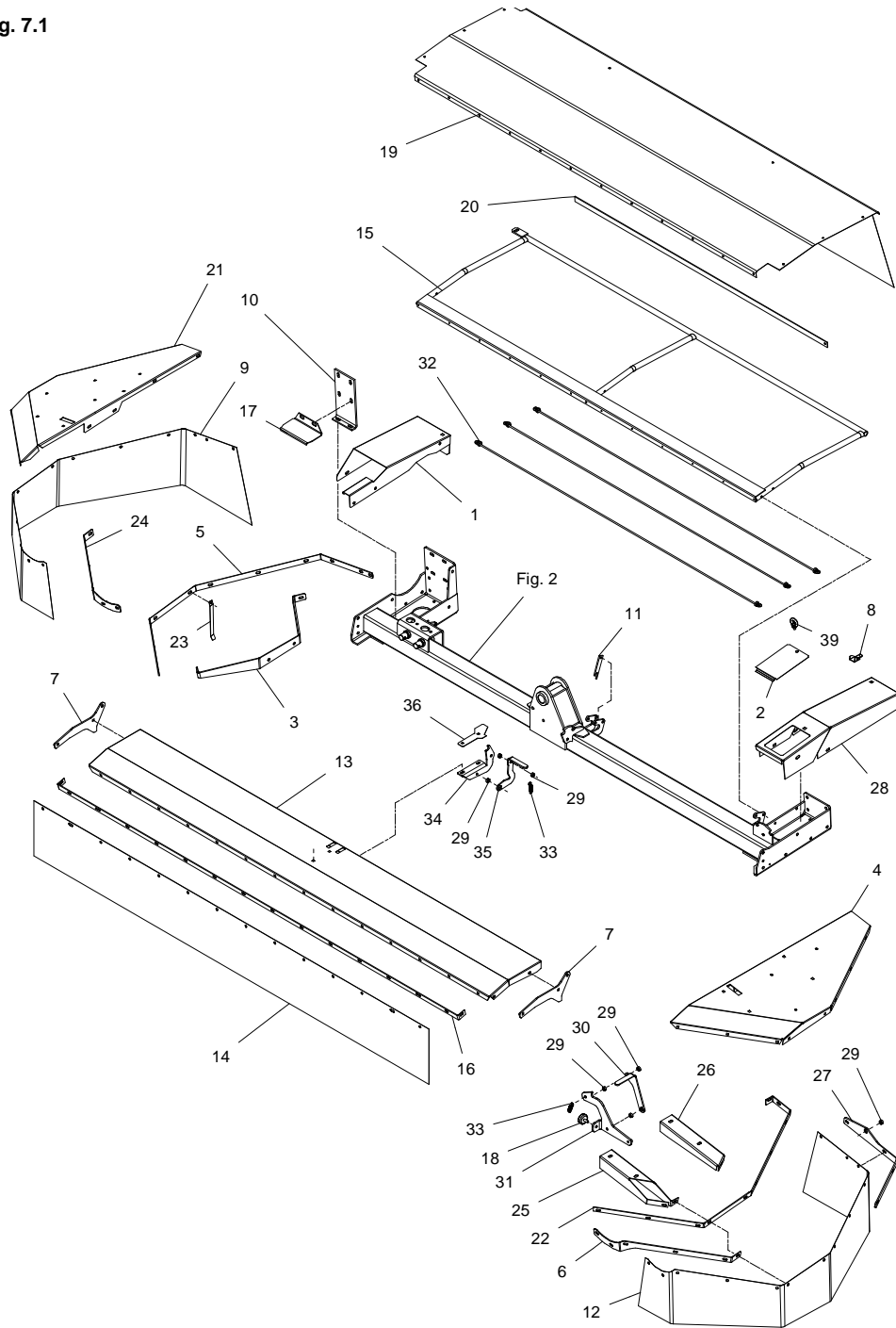

GXS-0005/1 GXS 9005

FIG. 7. 1

>=2650101612

POS.	VARENUMMER	ANTAL	BENÆVNELSE	BEZEICHNUNG	DESIGNATION	HERTIL, DAZU, TO THIS, A CECI
1.	2365-132X	1	SKÆRM SCHUTZ	GUARD	1213-3322 1213-4322 1220-3321 1220-4321 1241-2502 1241-3403	1 2 1 2 2 4
2.	2325-336X	1	DÆKSEL DECKEL	COVER	1241-2404	1
3.	2087-853A	1	SKÆRMBÆRER SCHUTZHALTER	HOLDER FOR GUARD		
4.	2087-833A	1	SKÆRM, VENSTRE SCHUTZ, LINKE	GUARD, LEFT	1213-4322 1220-4321 1241-2505	3 3 6
5.	2087-855X	1	SKINNE SCHIENE	RAIL		
6.	2322-237X	1	SKINNE F. SIDESKÆRM SCHIENE F. SEITENSCHUTZ	RAIL F. SIDE GUARD		
7.	2322-240X	2	HÆNGSEL SCHARNIER	HINGE	1213-3322 1220-3321 1241-2502	3 3 6
8.	2325-603X	1	BESLAG BESCHLAG	CLAMP	1215-2222 1220-2321 1241-2502	1 1 1
9.	2322-245X	1	DUG TUCH	CANVAS	1215-3226 1215-3228 1220-3321 1241-2502	3 7 10 8
10.	2325-628X	1	STIVER STUETZE	SUPPORT	1213-4224 1213-4327 1241-3403	4 2 8
11.	2325-335X	1	STOP STOP	STOP	1214-2126 1220-2321 1241-1202	1 1 1
12.	2322-246X	1	DUG TUCH	CANVAS	1215-3226 1215-3228 1220-3321 1241-2502	3 6 9 7
13.	2087-843A	1	FORSKÆRM SCHUTZ, FORDERE	GUARD, FRONT		
14.	2087-859A	1	DUG, FORRESTE TUCH, VORDERE	CANVAS, FRONT	1215-3226 1215-3228 1220-3321 1241-2502	4 13 17 17
15.	3325-595X	1	BØJLE BUEGEL	HOOP	1213-3322 1213-3622 1213-4622 1220-3122 1220-3321 1220-4321 1241-2404 1393-0105	1 3 3 3 3 3 1 2
16.	2087-846X	1	SKINNE SCHIENE	RAIL	1213-3322 1220-3321 1241-2502	3 3 6
17.	2087-794X	1	SKÆRM ABSCHIRMUNG	GUARD		
18.	1393-0186	2	GUMMIBUFFE GUMMIPUFFER	RUBBER BUFFER		
19.	2320-844A	1	DUG TUCH	CANVAS	1219-0599 1241-1206	12 12

Fig. 7.1

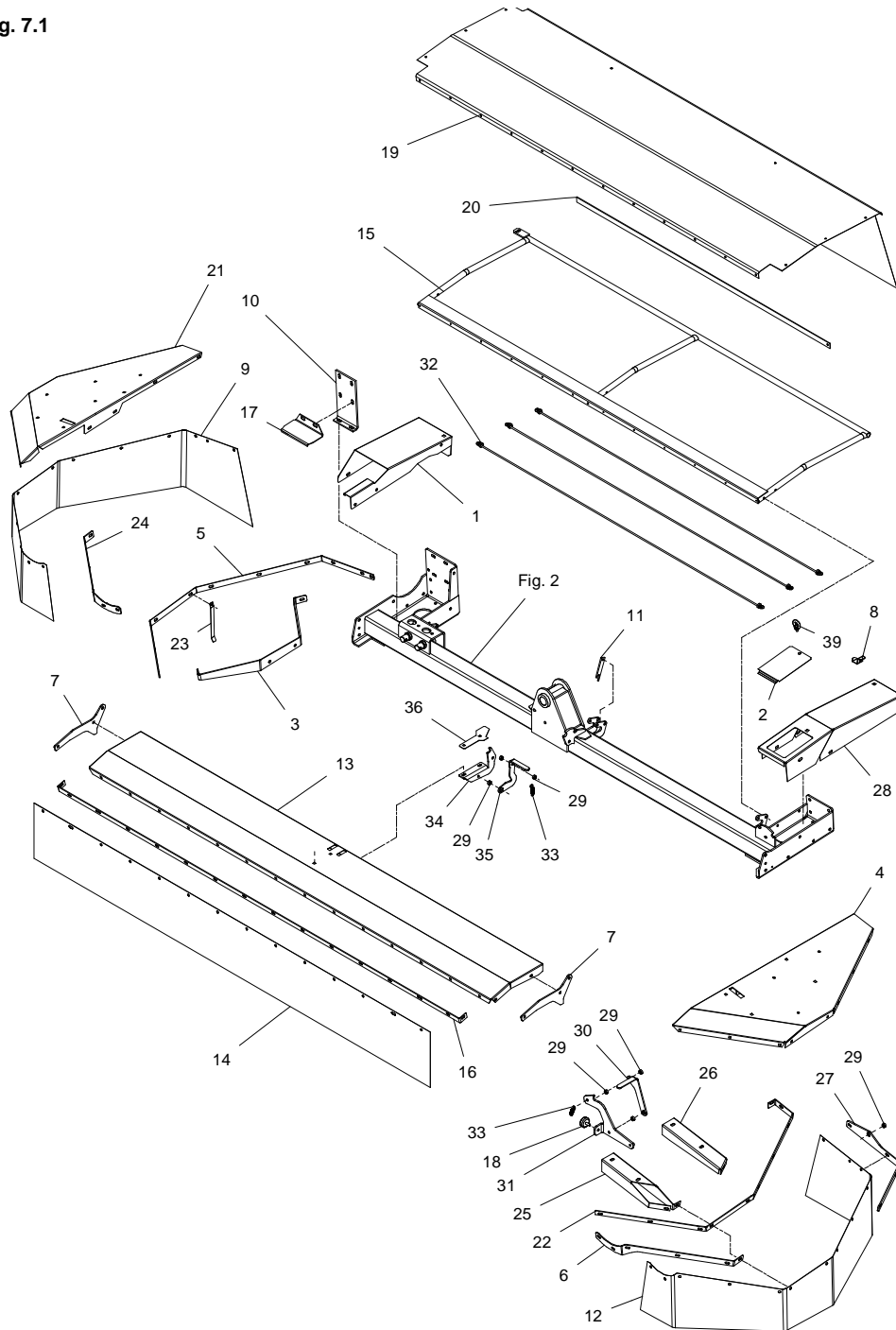

GXS-0005/1 GXS 9005

FIG. 7. 1

>=2650101612

POS.	VARENUMMER	ANTAL	BENÆVNELSE	BEZEICHNUNG	DESIGNATION	HERTIL, DAZU, TO THIS, A CECI
20.	2228-791X	1	SKINNE SCHIENE		RAIL	1213-2224 1241-1304
21.	2087-844A	1	SKÆRM, HØJRE SCHUTZ, RECHTE		GUARD, RIGHT	1213-4322 1220-4321 1241-2505
22.	2365-241A	1	SKINNE VENSTRE SCHIENE RECHTE		RAIL LEFT	
23.	2223-576X	1	HOLDER HALTER		HOLDER	
24.	2322-236X	1	HOLDER HALTER		SUPPORT	
25.	2322-215X	1	AFSTIVNING VENSTRE ABSTÜTZUNG RECHTE		BRACE RIGHT	
26.	2322-216X	1	AFSTIVNING VENSTRE ABSTÜTZUNG RECHTE		BRACE LEFT	
27.	2322-217X	1	HÆNGSEL SHARNIER		HINGE	
28.	2365-133A	1	SKÆRM SCHUTZBLECH		GUARD	1220-3922 1241-1304
29.	2322-243X	7	BØSNING BUCHSE		BUSH	1241-6702
30.	2322-238X	1	LÅS SCHLOSS		LOCK	
31.	2322-144X	1	HÆNGSEL SHARNIER		HINGE	1214-3122 1220-3321
32.	3325-291X	3	STROP STROPP		STRAP	1213-2222 1220-2321 1241-1304
33.	1432-2297	2	TRÆKFJEDER ZUGFEDER		TENSION SPRING	
34.	2322-247X	1	HÆNGSEL SHARNIER		HINGE	
35.	2322-244X	1	SKÆRMLÅS SCHTUTZSCHLOSS		GUARD LOCK	
36.	2322-239X	1	SKÆRM SCHUTZ		GUARD	
39.	1219-0404	1	ØJEBOLT M10-17 AUGENBOLZEN M10-17		EYE BOLT M10-17	
99.	3889-298X	1	TRANSFER GXS 9005 AUFKLEBER GXS 9005		TRANSFER GXS 9005	

Fig. 8

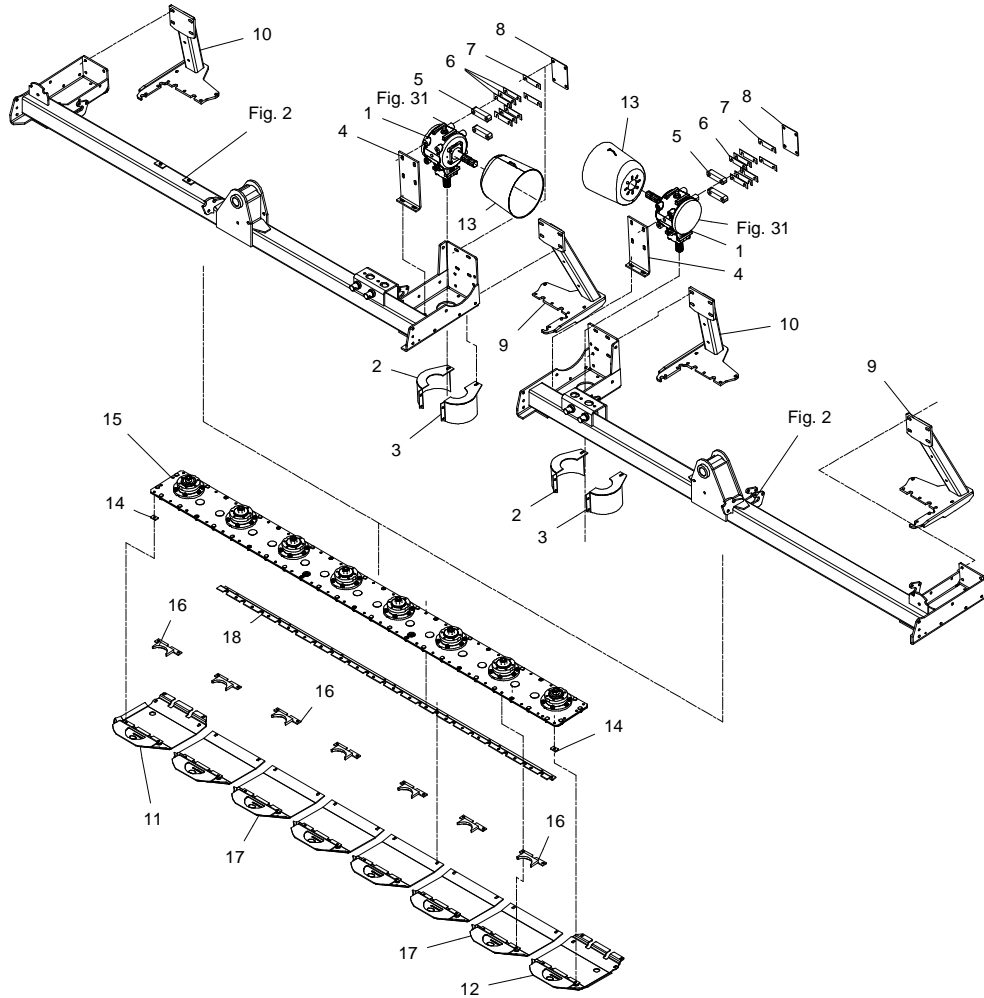

GXS-0005/1 GXS 9005

FIG. 8.

>=2650101501

HERTIL, DAZU,
TO THIS, A CECI

POS.	VARENUMMER	ANTAL	BENÆVNELSE	BEZEICHNUNG	DESIGNATION		
1.	3225-578A	2	VINKELTRÆK WINKELGETRIEBE		BEVEL GEAR		
2.	3325-612X	2	SKÆRM, VENSTRE SCHUTZ, LINKE		GUARD, LEFT		
3.	3325-611X	2	SKÆRM, VENSTRE SCHUTZ, LINKE		GUARD, LEFT	1213-3222	2
						1213-3322	2
						1220-3321	4
						1241-2502	8
4.	2325-628X	2	STIVER STUETZE		SUPPORT	1213-4224	4
						1213-4327	2
						1241-3403	8
5.	2229-501X	4	MELLEMLEG ZWISCHENAUSLEGER		SHIM		
6.	2225-576X	12	MELLEMLEG 2 MM ZWISCHENLAGE 2 MM		SHIM 2 MM		
7.	2225-577X	4	MELLEMLEG 1 MM ZWISCHENLAGE 1 MM		SHIM 1 MM		
8.	2322-136X	2	SPÆNDEPLADE SPANNPLATTE		RETAINING PLATE	1214-4228	4
						1241-9982	2
9.	3088-571X	2	BEN, VENSTRE BEIN, LINKE		LEG, LEFT		
10.	3088-575X	2	BEN, HØJRE BEIN, RECHTE		LEG, RIGHT		
11.	3088-564X	2	SLÆBESKO, YDRE GLEITKUFE, ÅUSSER		GUIDE SHOE, OUTER	1215-3320	2
						1219-0210	7
						1220-3323	9
						1241-2502	2
12.	3088-563X	2	SLÆBESKO, YDRE - VENSTRE GLEITKUFE, ÅUSSER - LINKE		GUIDE SHOE, OUTER - LEFT	1215-3320	2
						1219-0210	7
						1220-3323	9
						1241-2502	2
13.	2210-399X	2	PTO-SKÆRM, OVAL PTO-SCHUTZ, OVAL		PTO-GUARD, OVAL		
14.	2088-566X	4	MELLEMLEG DICHTUNG		DISTANCE PIECE		
15.	1380-0228	2	KNIVBJÆLKE 8-SKIVER MÄHBALKEN 8-SCHIEBEN		CUTTER BAR 8-DISC		
16.	3088-554X	14	MODSKER GEGENSCHNEIDE		SHEAR BAR		
17.	3088-549X	12	SLÆBESKO GLEITKUFE		GUIDE SHOE		
18.	2088-567X	2	FORSTÆRKNING VERSTÄRKERUNG		REINFORCEMENT		

Fig. 9

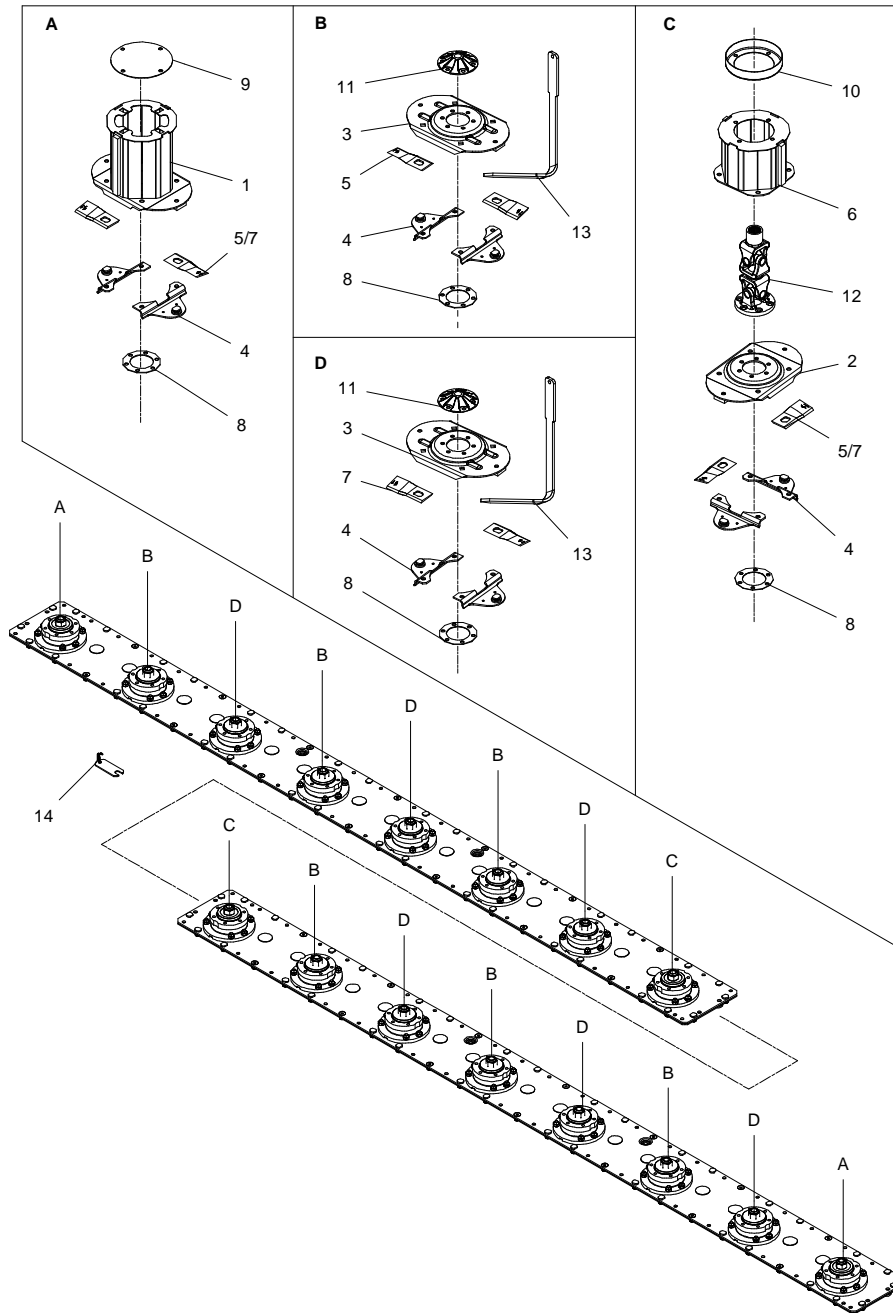

GXS-0005/1 GXS 9005

FIG. 9.

>=2650101501

HERTIL, DAZU,
TO THIS, A CECI

POS.	VARENUMMER	ANTAL	BENÆVNELSE	BEZEICHNUNG	DESIGNATION		
1.	3088-541X	2	SKIVE SCHEIBE		WASHER	1213-3222 1220-3922	4 4
2.	3088-539X	1	INDGANGSSKIVE ANTRIEBSSCHEIBE		INPUT WASHER		
3.	3088-536X	12	SKIVE SCHEIBE		WASHER	1215-4220 1220-4323 1241-3403	4 4 4
4.	3229-517A	32	KNIVHOLDER MESSERHALTER		KNIFE HOLDER	1219-0245 1220-4323 1241-3403	2 2 2
5.	1380-0047	16	KNIV H. VREDET 55-4-134 MESSER, RECHTE		KNIFE, RIGHT		
6.	3087-449A	2	TROMLE, INDGANG TROMMEL, EIN		BARREL, IN	1213-3224 1219-0290 1220-3323	4 4 4
7.	1380-0046	16	KNIV, VENSTRE MESSER, LINKS		KNIFE, LEFT		
8.	2085-704X	16	MELLEMLÆG DICHTUNG		DISTANCE PIECE		
9.	2089-180X	2	TÆTNING DICHTUNG		SEAL		
10.	2225-397X	4	TÆTNING DICHTUNG		SEAL	1213-3224	8
11.	2085-703X	12	TOP OBERTEIL		TOP	1213-3224 1241-2402	6 6
12.	1350-0144	2	BJÆLKEDREV L= 312 MM BALKEN L= 312 MM		CUTTERBAR L= 312 MM	1219-0266	6
13.	2083-706B	2	VÆRKTØJ WERKZEUG		TOOL		
14.	3210-436X	2	KONTROLLERE KONTROLLEHRE		CONTROL GAUGE		

Fig. 10

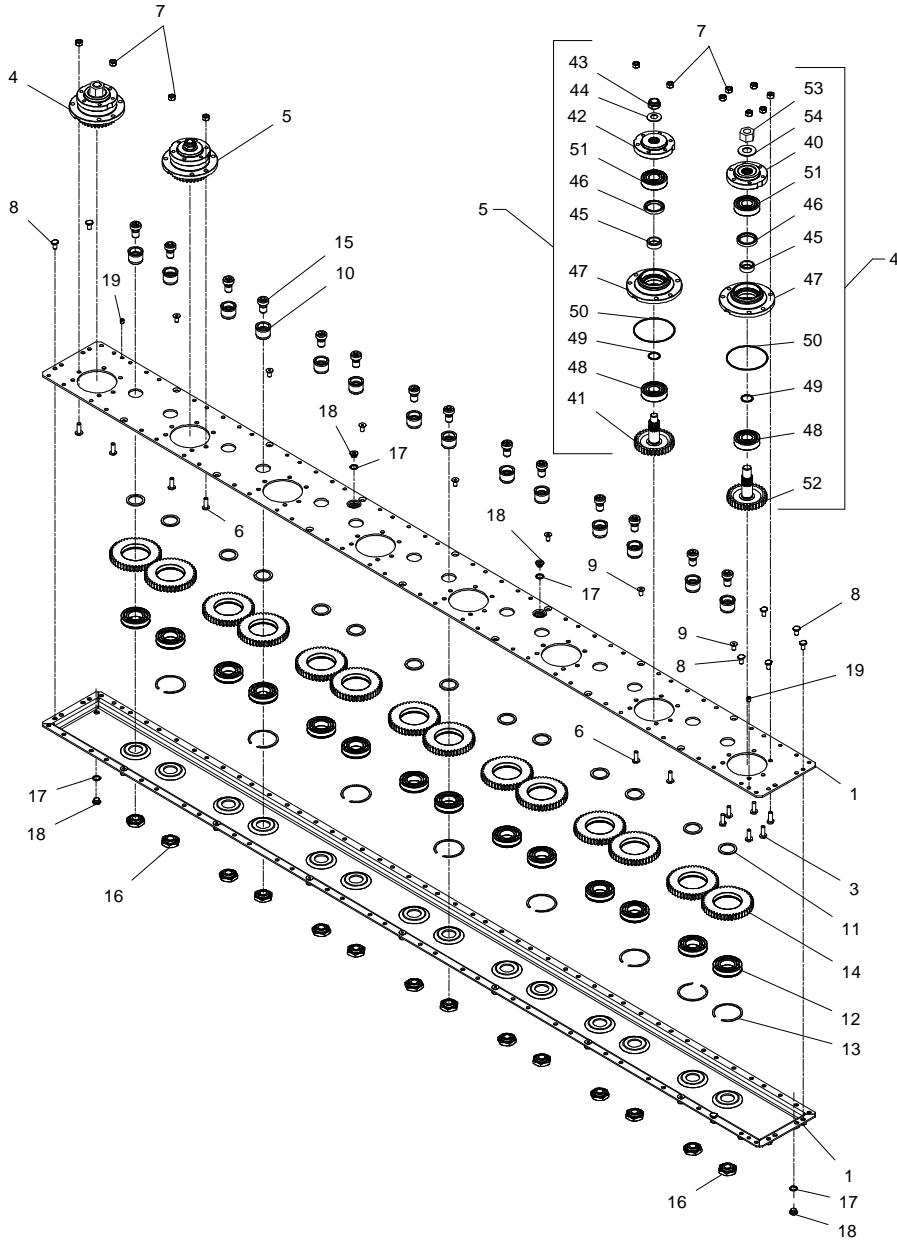

GXS-0005/1 GXS 9005

FIG. 10.

>=2650101501

HERTIL, DAZU,
TO THIS, A CECI

POS.	VARENUMMER	ANTAL	BENÆVNELSE	BEZEICHNUNG	DESIGNATION
.	1380-0228		KNIVBJÆLKE 8-SKIVER MÅHBALKEN 8-SCHEIBEN		CUTTER BAR 8-DISC
1.	3085-747X	1	KNIVBJÆLKE HALVDEL 8-SK SCHNITTBALKEN		CUTTERBAR
3.	1219-0210	34	SKRUE M10-30 SCHRAUBE M10-30	12.9 DELTA B 12.9 DELTA B	SCREW M10-30 12.9 DELTA B
4.	3085-738A	2	LEJEHUS DREV RITZEL LAGERGEHÅUSE		PINION BEARINGHOUSING
5.	3085-705X	6	LEJEHUS LAGERGEHÅUSE		BEARING HOUSING
6.	2085-733X	14	KNIVBJÆLKE SKRUE SCHNITTBALKEN SCHRAUBE		SCREW FOR CUTTERBAR
7.	2085-729X	98	MØTRIK M10 H=10 MUTTER M10 H=10		NUT M10 H=10
8.	1219-0208	36	KNIVBJÆLKE SKRUE SCHNITTBALKEN SCHRAUBE		SCREW FOR CUTTERBAR
9.	1219-0227	14	UNBRACOSKRUE M10-20 MK INNENSEKSKANTSCHR M10-20 MK		ALLEN SCREW M10-20 MK
10.	2085-717X	14	TAP ZAPFEN		DOWEL
11.	2085-719X	14	SKIVE 40,3X51,3X3 SCHEIBE 40,3X51,3X3		WASHER 40,3X51,3X3
12.	2085-720X	14	LEJE 6208 N/C3 LAGER 6208 N/C3		BEARING 6208 N/C3
13.	2085-721X	8	SPRINGRING KLEMMRING		SPRINGRING
14.	2085-724X	14	MELLEMHJUL Z45 M3 ZWISCHENRAD Z45 M3		INTERMEDIATE WHEEL Z45 M3
15.	2085-718X	14	SKRUE M20X18 SCHRAUBE M20X18		SCREW M20X18
16.	2085-723X	14	MØTRIK MUTTER		NUT
17.	1315-9671	4	SKIVE 17 X 22 X 1,5 SCHEIBE 17 X 22 X 1,5		WASHER 17 X 22 X 1,5
18.	2085-731X	4	PROP 3/8" VERSCHLUSS 3/8"		PLUG 3/8"
19.	2085-735X	2	SPÆNDSTIFT M10X12 D1481 SPANNSTIFT M10X12 D1481		ROLL PIN M10X12 D1481
40.	2085-739X	1	FLANGE FLANSCH		FLANGE
41.	2085-706X	1	TANDHJUL Z34 M20 ZAHNRAD Z34 M20		SPROCKET WHEEL Z34 M20
42.	2085-707X	1	FLANGE FLANSCH		FLANGE
43.	2085-709X	1	LÅSEMØTRIK M20X1,5 GEGENMUTTER M20X1,5		LOCK NUT M20X1,5
44.	1434-0108	1	TALLERKENFJEDER 20,0-40-2,5 TELLERFEDER 20,0-40-2,5		DISC SPRING 20,0-40-2,5
45.	2085-710X	1	BØSNING BUCHSE		BUSH
46.	2085-711X	1	OLIETÆTNINGSRING DICHTUNGSRING ØL		SEAL RING OIL
47.	2085-708X	1	LEJEHUS LAGERGEHÅEUS		BEARING HOUSING

Fig. 10

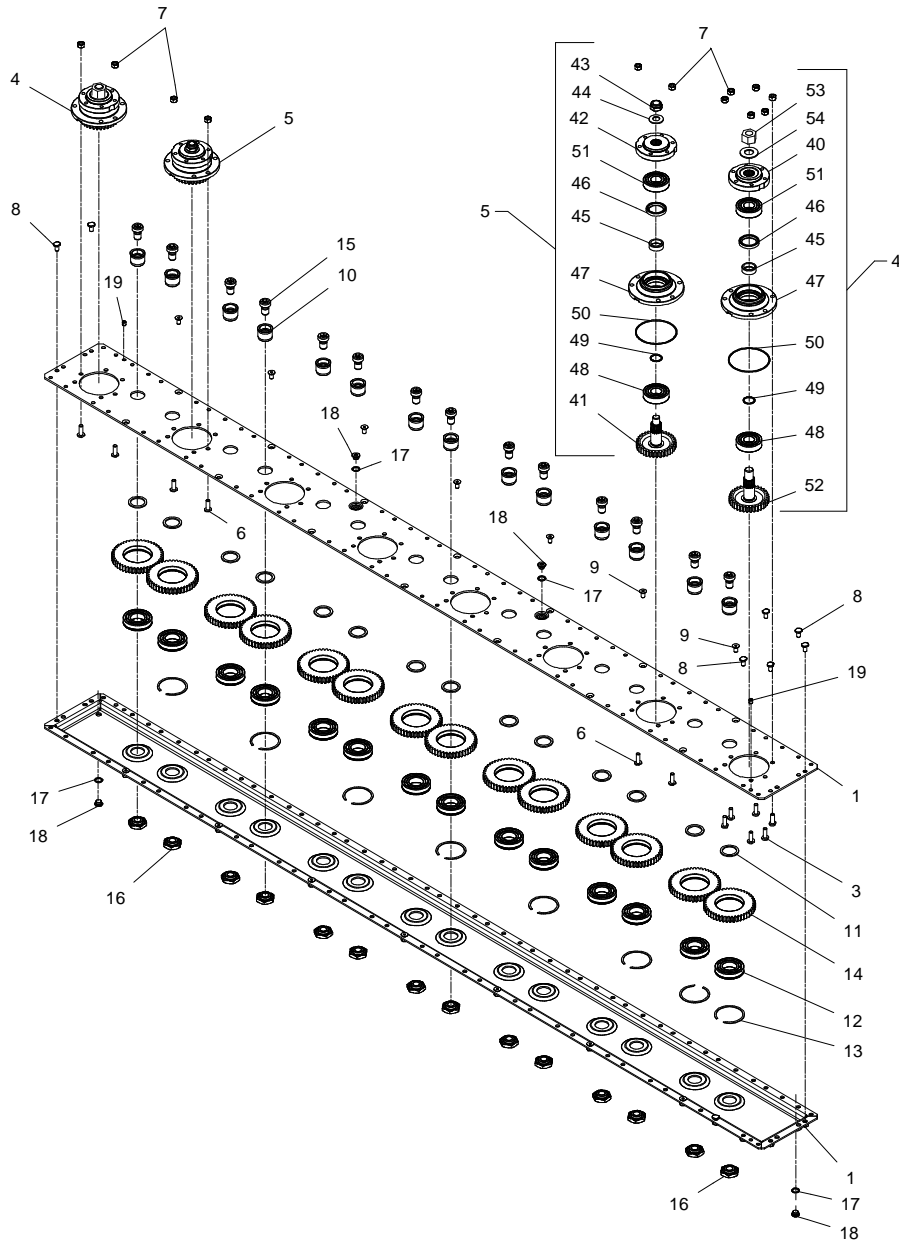

GXS-0005/1 GXS 9005

FIG. 10.

>=2650101501

HERTIL, DAZU,
TO THIS, A CECI

POS.	VARENUMMER	ANTAL	BENÆVNELSE	BEZEICHNUNG	DESIGNATION
48.	2085-712X	1	LEJE 6306C3/Z2 LAGER 6306C3/Z2		BEARING 6306C3/Z2
49.	2085-714X	1	O-RING 3112 O-RING 3112		O-RING 3112
50.	2085-715X	1	O-RING O-RING		O-RING
51.	2085-716X	1	KUGLELEJE 6306 C3 2RS KUGELLAGER 6306 C3 2RS		BALL BEARING 6306 C3 2RS
52.	2085-750X	1	TANDHJUL Z34 M24 ZAHNRAD Z34 M24		SPROCKET WHEEL Z34 M24
53.	2085-751X	1	LÅSEMØTRIK M24X1,5 GEGENMUTTER M24X1,5		LOCK NUT M24X1,5
54.	1434-0111	1	TÅLL-FJEDER 25,4-50-3		

Fig. 11

GXS-0005/1 GXS 9005

FIG. 11.

>=2650101501

HERTIL, DAZU,
TO THIS, A CECI

POS.	VARENUMMER	ANTAL	BENÆVNELSE	BEZEICHNUNG	DESIGNATION
1.	2279-221X	2	DÆKSEL DECKEL		COVER
2.	2279-223X	2	AFSTANDSRING Distanzring		DISTANCE RING
3.	1331-2303	4	KUGLELEJE 6005 2RS KUGELLAGER 6005 2RS		BALL BEARING 6005 2RS
4.	2279-023X	2	SKIVE SCHEIBE		WASHER
5.	1219-0220	2	UNBRACOSKRUE M12-25 MC INNENSECHSKANTSCHR. M12-25 MC		ALLEN SCREW M12-25 MC
6.	1165-0189	2	AFDÆKNINGSPROP ABDECKUNGSVERSCHLUSS		COVERING PLUG
7.	1255-4102	4	LÅSERING 47 MM INDVENDIG SICHERINGSRING 47 MM INNEN		SNAP RING 47 MM INNER
8.	3279-502X	2	TALLERKEN SCHEIBE		REINFORCED DISC
9.	3088-078X	1	ARM F. SKÅRRULLE ARN F. SCHWADROLLE		ARM F. SWATH ROLLER
10.	3088-079X	1	SKÅRRULLE, SML., VENSTRE SCHWADROLLE SATZ, LINKS		SWATH ROLLER SET, LEFT
19.	3088-050X	1	ARM F. SKÅRRULLE ARM F. SCHWADROLLE		ARM F. SWATH ROLLER
20.	3088-076X	1	SKÅRRULLE, SML. SCHWADROLLE SATZ		SWATH ROLLER SET

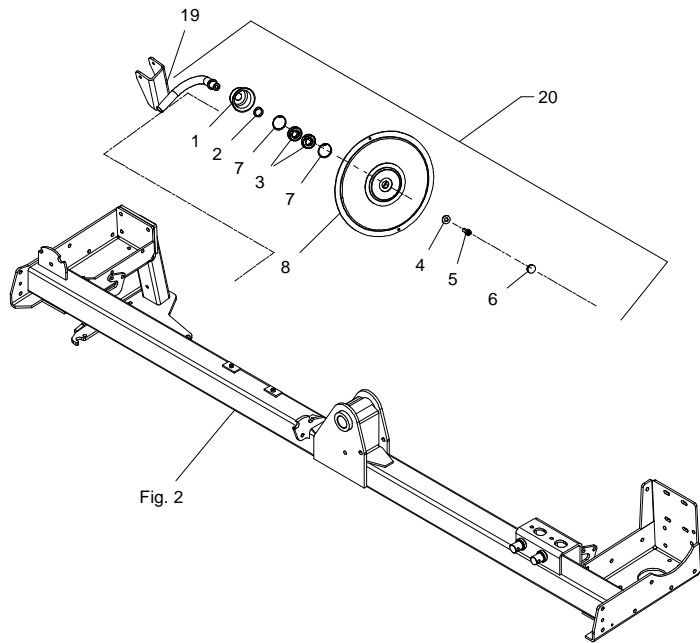

Fig. 2

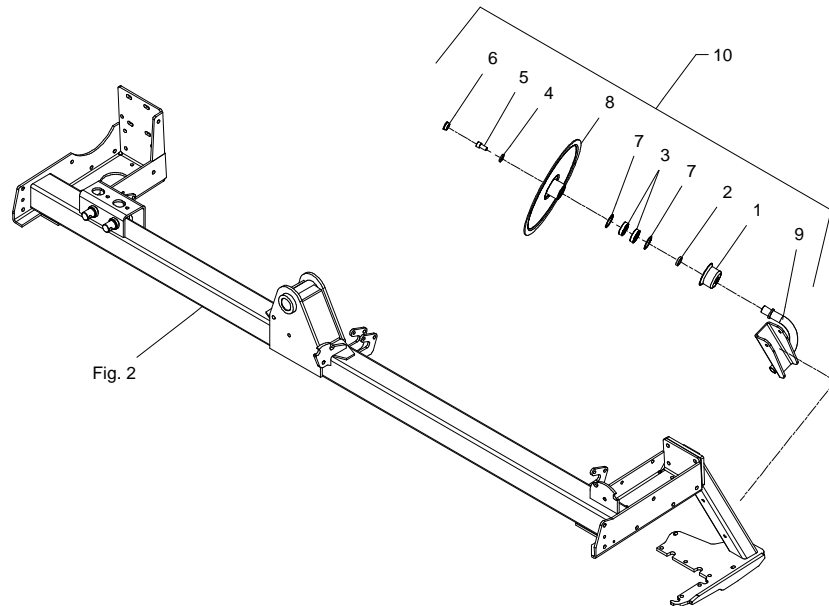
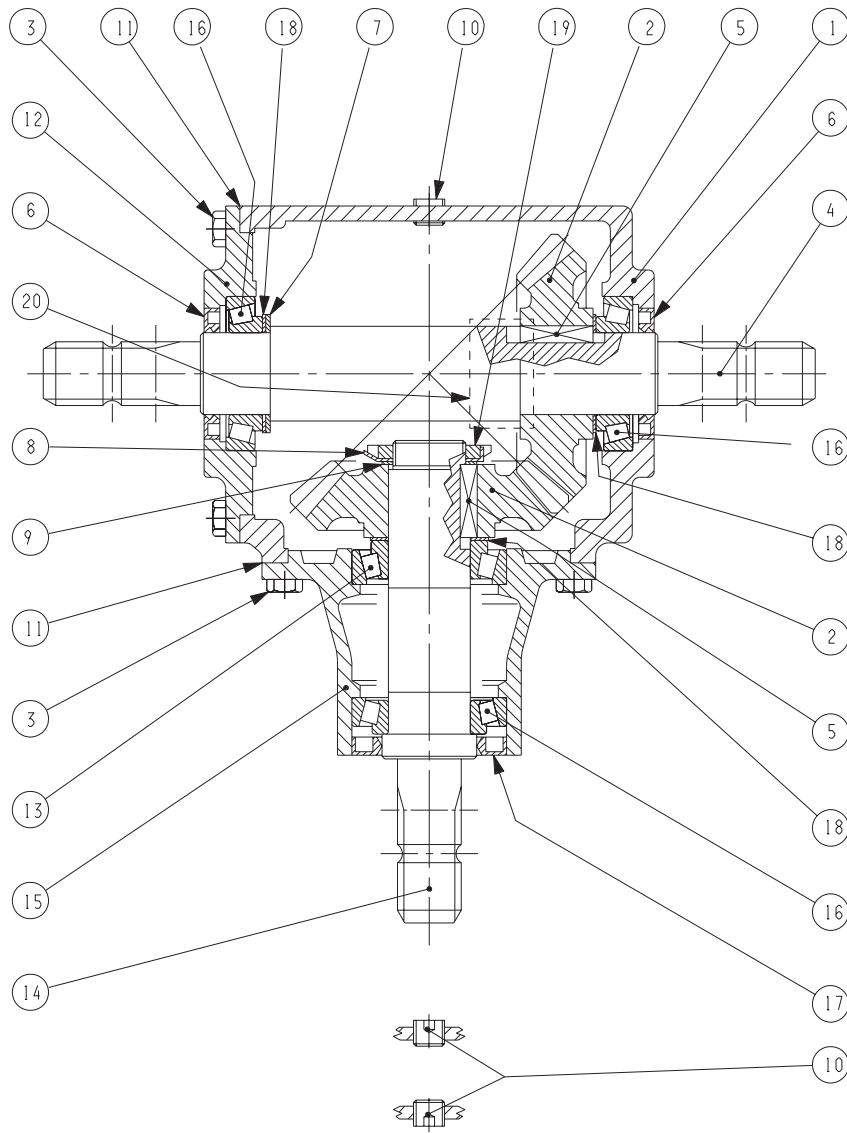

Fig. 2

Fig. 30



GXS-0005/1 GXS 9005

FIG. 30.

>=2650101501

HERTIL, DAZU,
TO THIS, A CECI

POS.	VARENUMMER	ANTAL	BENÆVNELSE	BEZEICHNUNG	DESIGNATION
.	3113-233X		VINKELTRÆK, 540 RPM WINKELGETRIEBE, 540 RPM		BEVEL GEAR, 540 RPM
1.	1315-9378	1	HUS GEHÄUSE		HOUSING
2.	1315-9390	2	GEAR GETRIEBE		GEAR
3.	1315-9380	16	BOLT BOLT		BOLT
4.	1315-9391	1	AKSEL WELLE		SHAFT
5.	1315-9392	1	PASFEDER B14-9-40 FEDERKEIL B14-9-40		FLAT KEY B14-9-40
6.	1315-9383	2	OLIETÆTNINGSRING 45-72-8 DICHTUNGSRING 45-72-8		OIL SEAL 45-72-8
7.	1315-9384	1	SKIVESÆT SCHEIBENSATZ		SET AF WASHERS
8.	1315-9114	1	LÅSESKIVE FEDERSCHEIBE		SPRING WASHER
9.	1315-9385	1	SKIVESÆT SCHEIBENSATZ		SET AF WASHERS
10.	1315-9245	4	PROP ROHRVERSCHLUSS		PLUG
11.	1315-9256	2	PAKNING DICHTUNG		GASKET
12.	1315-9386	1	DÆKSEL DECKEL		COVER
13.	1315-9387	1	KUGLELEJE, KONISK 32209 ROLLENLAGER, KONISK 32209		ROLLING BEARING, CONE 32209
14.	1315-9388	1	AKSEL WELLE		SHAFT
15.	1315-9389	1	FORLÆNGER VERLAENGERUNG		EXTENSION
16.	1331-9907	3	KONISK RULLELEJE 30209 KON. ROLLENLAGER 30209		TAPER ROLLER BEARING 30209
17.	1315-9227	1	OLIETÆTNINGSRING 52-85-10 DICHTUNGSRING 52-85-10		OIL SEAL 52-85-10
18.	1315-9132	3	AFSTANDSSKIVE Distanzscheibe		DISTANCE WASHER
19.	1315-9113	1	MØTRIK MUTTER		NUT

Fig. 31

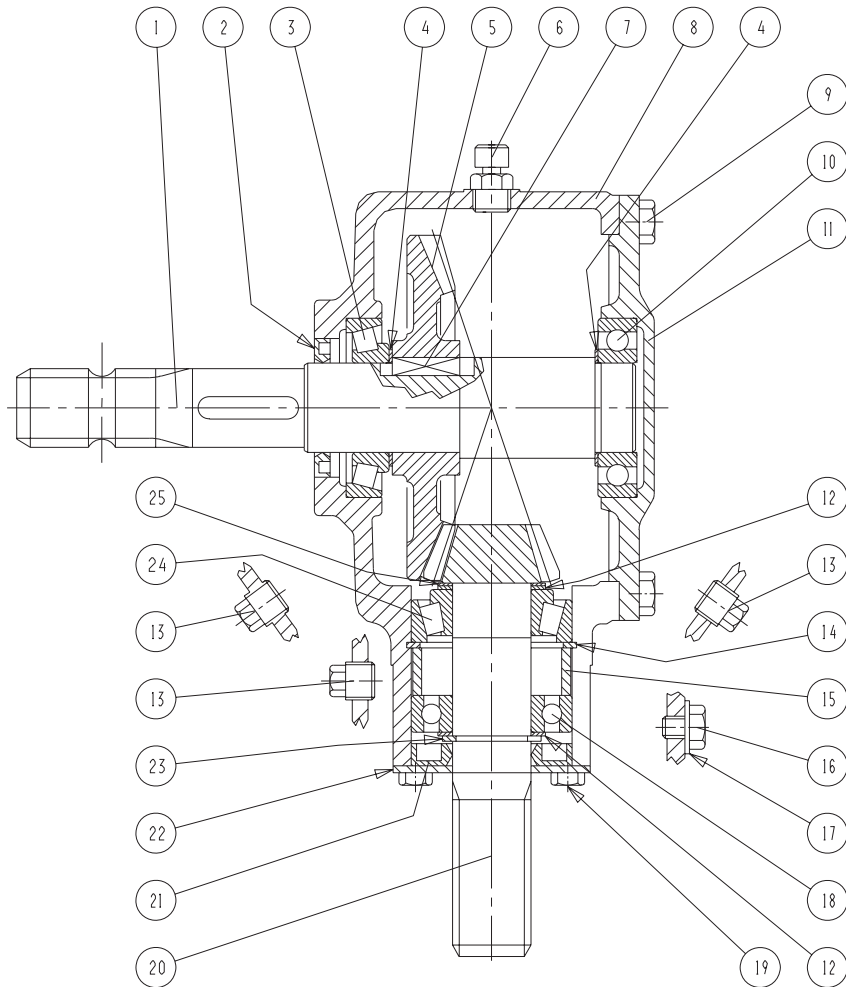

GXS-0005/1 GXS 9005

FIG. 31.

>=2650101501

HERTIL, DAZU,
TO THIS, A CECI

POS.	VARENUMMER	ANTAL	BENÆVNELSE	BEZEICHNUNG	DESIGNATION
.	3225-578A		VINKELTRÆK WINKELGETRIEBE		BEVEL GEAR
1.	1315-9164	1	AKSEL WELLE		SHAFT
2.	1332-4502	1	OLIETÆTNINGSRING M40-62-7 DICHTUNGSRING M40-62-7		OIL SEAL M40-62-7
3.	1331-9994	1	RULLELEJE KONISK 30208A ROLLENLAGER 30208A		ROLLER BEARING 30208A
4.	1315-9109	2	AFSTANDSRING, SÆT DISTANZRING, SATZ		DISTANCE RING, SET
5.	1315-9163	1	KRONHJUL KRONRAD		CROWN WHEEL
6.	1315-9167	1	UDLUFTNINGSPROP ENTLÛFTUNGSSCHRAUBE		AIR ESCAPE PLUG
7.	1338-0102	1	PASFEDER 12-8-28 FEDERKEIL 12-8-28		FLAT KEY 12-8-28
8.	1315-9317	1	HUS GEHÆUSE		HOUSING
9.	1213-3224	8	STÅLSÆTSKRUE M10-25 ST. SÆTSCHRAUBE M10-25		STEEL SET SCREW M10-25
10.	1331-3106	1	KUGLELEJE 6208 KUGELLAGER 6208		BALL BEARING 6208
11.	1315-9318	1	DÆKSEL DECKEL		COVER
12.	1315-9140	2	SKIVESÆT DISTANZSCHEIBENSATZ		SET OF SHIMS
13.	1311-2201	3	PROP VERSCHLUSS		PLUG
14.	1255-6101	1	LÅSERING 72 MM INDVENDIG SICHERINGSRING 72 MM INNEN		SNAP RING 72 MM INNER
15.	1315-9301	1	AFSTANDSBØSNING DISTANZBUCHSE		DISTANCE BUSH
16.	1315-9136	1	BOLT M10-10 BOLZEN M10-10		BOLT M10-10
17.	1315-9282	1	KOBBERSKIVE 10,5-18 KUPPERSCHEIBE 10,5-18		COPPER WASHER 10,5-18
18.	1331-3104	1	KUGLELEJE 6207 KUGELLAGER 6207		BALL BEARING 6207
19.	1213-2126	4	STÅLSÆTSKRUE M8-15 ST. SÆTSCHRAUBE M8-15		STEEL SET SCREW M8-15
20.	1315-9319	1	SPIDSHJUL Z=12 ZÄHNRAD Z=12		BEVEL PINION WHEEL Z=12
21.	1332-3602	1	OLIETÆTNINGSRING 35-72-10 DICHTUNGSRING 35-72-10		OIL SEAL 35-72-10
22.	1315-9165	1	DÆKSEL DECKEL		COVER
23.	1315-9191	1	LÅSERING 35 SICHERINGSRING 35		SNAP RING 35
24.	1331-9910	1	RULLELEJE ROLLENLAGER		ROLLER BEARING
25.	1315-9220	1	PASSKIVE 35.3-1.3 SCHEIBE 35.3-1.3		WASHER 35.3-1.3

Fig. 40

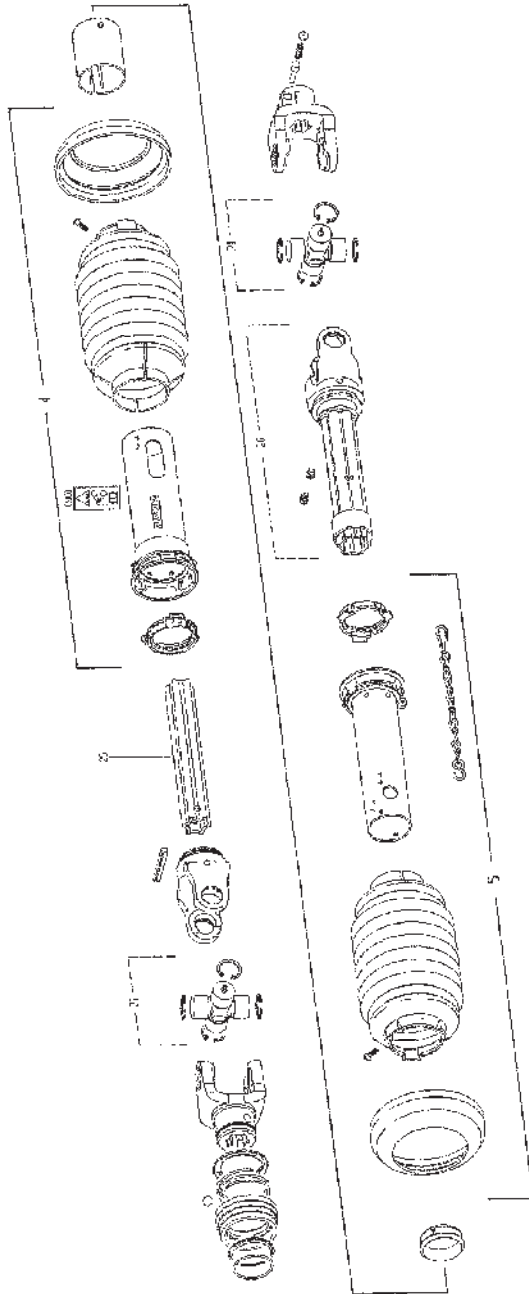

GXS-0005/1 GXS 9005

FIG. 40.

>=2650101501

HERTIL, DAZU,
TO THIS, A CECI

POS.	VARENUMMER	ANTAL	BENÆVNELSE	BEZEICHNUNG	DESIGNATION
.	1340-5117		KRAFTOVERFØRINGSAKSEL GELENKWELLE		PTO SHAFT
4.	1342-3088	1	BESKYTTELSERØR, UDV. SCHUTZROHR, AUSSEN		PROTECTION TUBE, OUTER
5.	1342-3089	1	RØR, INDV. SCHUTZ, INNERE		GUARD, INNER
21.	1340-9212	2	KRYD KREUTZGARNITURE		CENTRE CROSS
25.	1501-0113	1	PROFILRØR S4LH 1000 MM PROFILROHR GR.S4LH 1000 MM		PROFILE TUBE SIZE S4LH 1000 MM
26.	1501-0117	1	PROFILRØR, 1000 MM PROFILROHR, 1000 MM		PROFIL TUBE, 1000 MM

Fig. 41

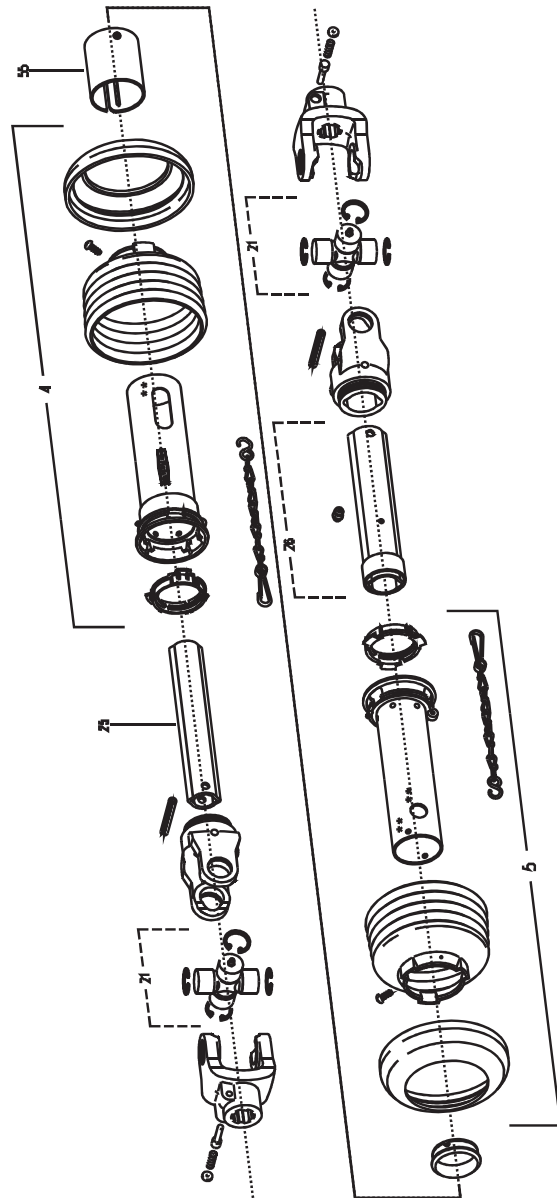

GXS-0005/1 GXS 9005

FIG. 41.

>=2650101501

HERTIL, DAZU,
TO THIS, A CECI

POS.	VARENUMMER	ANTAL	BENÆVNELSE	BEZEICHNUNG	DESIGNATION
.	1340-5112		KRAFTOVERFØRINGSAKSEL GELENKWELLE		PTO SHAFT
4.	1501-0010	1	BESKYTTELSERØR UDV. 1000 MM SCHUTZROHR AUSSEN, 1000 MM		PROTECTION TUBE, OUTER 1000 MM
5.	1501-0009	1	BESKYTTELSERØR, INDV. 1000 MM SCHUTZROHR INNEN, 1000 MM		PROTECTION TUBE INNER, 1000 MM
21.	1340-9228	2	KRYDS KREUTZ		CROSS
25.	1501-0111	1	PROFILRØR 1BH 1000 MM PROFILROHR GR.1BH 1000 MM		PROFILE TUBE SIZE 1BH 1000 MM
26.	1501-0110	1	PROFILRØR 2AG 1000 MM PROFILROHR GR.2AG 1000 MM		PROFIL TUBE SIZE 2AG 1000 MM
55.	1341-9538	1	AFDÆKNING ABDECKUNG		COVER

Fig. 80

TILBEHØR - ZUBEHÖR - ACCESSORIES

GXS-0005/1 GXS 9005

FIG. 80.
TILBEHØR, ZUBEHÖR, ACCESSORIES

>=2650101501

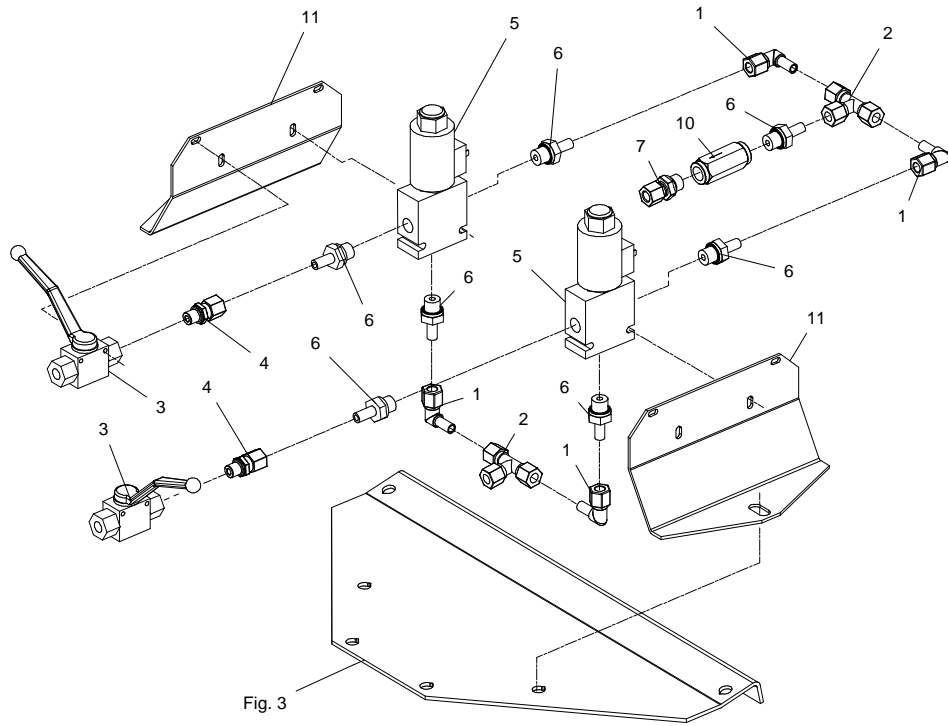
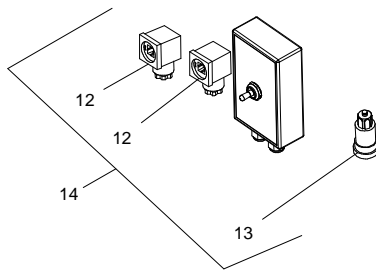

Fig. 3



POS.	VARENUMMER	ANTAL	BENÆVNELSE	BEZEICHNUNG	DESIGNATION	HERTIL, DAZU, TO THIS, A CECI	
1.	1311-8603	4	VINKELFORSKRUNING WINKELVERSCHRÄUBUNG		ANGLE COUPLING		
2.	1311-8406	2	T-STYKKE T-STUECK		T-PIECE		
3.	1317-0725	2	KUGLEHANE 1/4" KUGELHAHN 1/4"		BALL TAP 1/4"	1214-1101	1
						1220-1321	1
4.	1311-1411	2	RØRFORSKRUNING ROHRVERSCHRÄUBUNG		PIPE COUPLING		
5.	1317-0106	2	3/2-VENTIL 3/2-VENTIL		3/2-VALVE	1214-1126	1
						1220-1323	1
						1241-1407	1
6.	1311-8535	7	RØRSTUDS ROHRSTUTZEN		PIPE STUB		
7.	1311-8534	1	FORSKRUNING VERSCHRÄUBUNG		SCREWED CONNECTION		
10.	1317-0744	1	KONTRAVENTIL KONTRAVENTIL		NON-RETURN VALVE		
11.	2365-448X	2	BESLAG BESCHLAG		FITTING	1213-3224	2
						1220-3321	2
						1241-2401	2
12.	1391-9038	2	STIK STECKER		PLUG		
13.	1391-0703	1	STIK, 2-POLET STECK, 2-POLET		PLUG, 2-POLES		
14.	3362-143X	1	KONTAKT SCHALTER		SWITCH		

Valid from: | Gültig ab:
Valable à partir de: | Gyldig fra:
01. 04. 2011

Serial No.: | Maschinen Nr.:
No. de serie: | Fabrikationsnr.:
2650101501