

GXS 3205

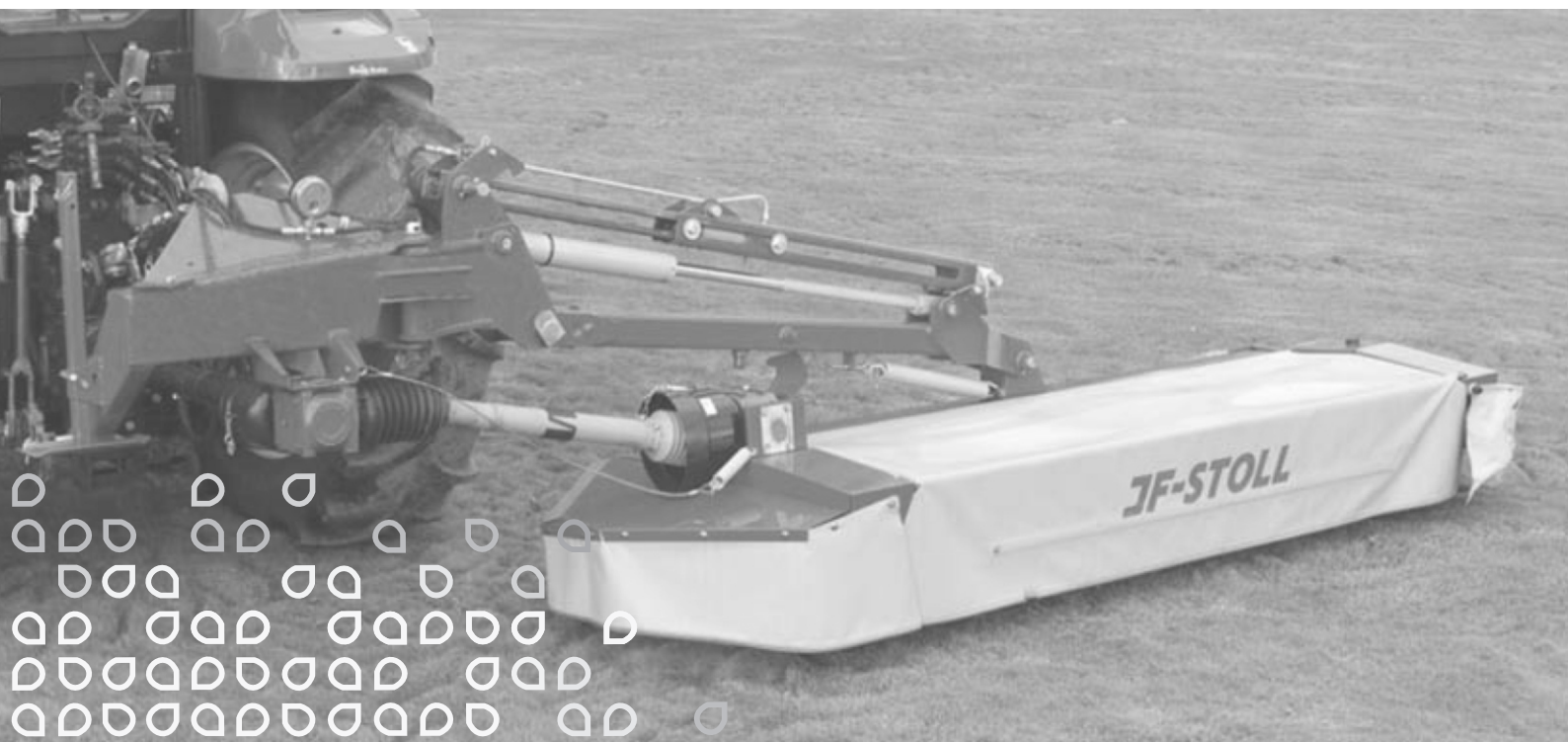

Reservedelsliste
Spare parts list
Ersatzteilliste
Liste de pièce de rechange

X3

JF-STOLL

Always state the serial number and if possible the year of the machine when ordering spare parts whereby you save time and money and facilitates matters for us.
Please enter the number of your machine here:

No..... Delivered on the / 20.....

Appropriate when ordering parts.
The serial number is located as shown on the figure.

Bei Ersatzteilbestellungen ist die Fabrikationsnummer Ihrer Maschine unbedingt anzugeben.
Das erspart Ihnen Zeit, Geld und Ärger und erleichtert uns die Abfertigung.
Tragen Sie die Nummer Ihrer Maschine bitte hier ein:

Nr..... Geliefert am / 20.....

dann haben Sie bei Ersatzteilbestellungen immer die Nummer bei der Hand.
Die Fabrikationsnummer ist im Rahmen eingeschlagen, siehe Figur.

Lorsque vous commandez des pièces détachées, indiquez toujours le numéro de série de votre machine et si possible son année de fabrication. Vous éviterez des pertes de temps et vous nous faciliterez le travail.

Prière de noter ici le numéro de série de votre machine:

Numéro..... Livrée le / 20.....

Ceci vous sera utile lorsque vous commanderez des pièces.
Le numéro de série est gravé dans le cadre comme indiqué sur la figure.

Bestiller De reservedele så opgiv venligst maskinens fabrikationsnummer og eventuelt købsår. Det sparer Dem tid, penge og ærgrelser og os unødigt besvær.
De kan notere nummeret på Deres maskine her:

Nr..... Leveret den / 20.....

så har De det ved hånden, når De eventuelt skal bestille reservedele.
Fabrikationsnummeret findes indhugget i rammen, som vist på figuren.

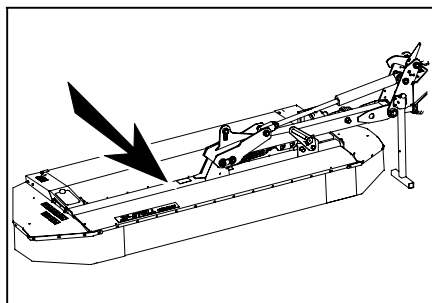

SPARE PARTS BOOK ERSATZTEILKATALOG CATALOGUE DE PIÈCES RESERVEDELSKATALOG

The book is divided into 5 passages:

1. Description of the spare part book.
2. Number key for assembly parts.
3. Number key showing on which figures the spare part numbers can be found.
4. Figure key showing on which figures the parts can be found.
5. Spare parts list.

Der Katalog ist in 5 Abschnitte eingeteilt:

1. Beschreibung des Ersatzteilkataloges.
2. Nummernschlüssel für Montagezubehör.
3. Nummernschlüssel mit Angabe der jeweiligen Ersatzteilnummer.
4. Figurliste mit Angabe, auf welche Figuren die Teile zu finden sind.
5. Ersatzteilliste.

Le catalogue est divisé en 5 sections:

1. Description du catalogue de pièces.
2. Liste de pièces de montage.
3. Numéros des pièces de rechange indiquant le numéro de figure.
4. Liste des figures indiquant sur quelle figure se trouvent les pièces.
5. Liste de pièces de rechange.

Kataloget er opdelt i 5 afsnit:

1. Beskrivelse af reservedelskataloget.
2. Nummernøgle for monteringsdele.
3. Nummernøgle - viser på hvilke figurer reservedelsnumrene findes.
4. Figurnøgle - viser på hvilke figurer delene findes.
5. Reservedelsliste.

Description of the spare parts book: Beschreibung des Ersatzteilkataloges: Description du catalogue de pièces: Beskrivelse af reservedelskataloget:

The spare parts book is built up as follows:

Fig. 01-29 Standard	Fig. 50-59 Hub
Fig. 30-39 Gear	Fig. 60-79 Variation of standard (Accessory)
Fig. 40-49 PTO drives	Fig. 80- Accessory

Der Ersatzkatalog ist so aufgebaut:

Fig. 01-29 Standard	Fig. 50-59 Nabe
Fig. 30-39 Getriebe	Fig. 60-79 Variation vom Standard (Zubehör)
Fig. 40-49 Gelenkwellen	Fig. 80- Zubehör

Le catalogue de pièces est arrangé comme suit:

Fig. 01-29 Standard	Fig. 50-59 Moyeu
Fig. 30-39 Boîtier	Fig. 60-79 Variation du standard (Accessoire)
Fig. 40-49 Arbres à cardan	Fig. 80- Accessoire

Reservedelskataloget er opbygget således:

Fig. 01-29 Standard	Fig. 50-59 Nav
Fig. 30-39 Gear	Fig. 60-79 Variation af standard (Tilbehør)
Fig. 40-49 Kraftoverføringsaksler	Fig. 80- Tilbehør

Position No.:

The position No. marked "()" is not standard.
Is delivered as accessory.

Positionsnummer:

Die Positionsnummer, die mit "()" gezeichnet ist, ist nicht der Standard.
Wird als Zubehör geliefert.

No de pos.:

Le numéro de position marqué d'un "()" n'est pas une pièce standard.
Livrée comme accessoire.

Pos. nr.:

Positionsnummer mærket med "()" er ikke standard.
Leveres som tilbehør

Article no.:

The article no. marked "T" is not standard. Is delivered as accessories.
the article no. marked "+":
Modification is being made.

Warennummer:

Ist eine Warennummer mit "T" gekennzeichnet, wird sie als Zubehör geliefert.
Eine Warennummer mit "+" ist als Modifikation unterwegs.

No. D'article:

Le no d'article marqué d'un "T" n'est pas un article standard. Livré comme accessoire.
No. d'article marqué de "+":
Une modification viendra.

Varenr.:

Varennummer mærket med "T" er ikke standard. Leveres som tilbehør.
Varennummer mærket med "+":
ændring undervejs.

Designation:

>=0003219 <=0003448
Spare part used for machine from serial No. 3219 up to No. 3448 both Nos. included.

Benennung:

>=0003219 <=0003448
Ersatzteil für Maschinen von Fabrikationsnummer 3219 bis Nr. 3448.

Désignation:

>=0003219 <=0003448
Pièce de rechange employée sur machines à partir de no de série 3219 jusqu'à et y compris no 3448.

Benævnelse:

>=0003219 <=0003448
Reservedel anvendt på maskine fra og med fabrikationsnummer 3219 til og med nr. 3448

Quantity:

States quantity of parts for machine.
In connection with subassemblies:
Quantity for the assembly.

Anzahl:

Anzahl Teile je Maschine.
Bei Untersammlungen:
Anzahl je Sammlung.

Quantité:

Quantité de pièces par machine.
Pour les sous-ensembles: pièces par assemblage.

Antal:

Antal dele pr. maskine.
Ved undersamlinger: dele pr. samling.

POS.	VARENUMMER	ANTAL	BENÆVNELSE	BETEGNING	DESIGNATION	HERTEL, DAZU TO THIS, A CECI
33.	1340-9153 T	2	KRYDS KREUTZGARNITUR >=0003219 <=0003448	CENTRE		1341-9187 1
33.1	1350-7005	2	KRYDS KREUTZGARNITUR >=0003219	CENTRE		1350-9052 4 1350-9104 1
34.	1340-0196	1	PROFILAKSEL PROFILGABEL >=0003219 <=0003448	PROFIL FORK		
34.1	1350-8008	1	PROFILAKSEL PROFILGABEL >=0003249	PROFIL FORK		

To this:

States which and how many mounting assemblies (screws, nuts, discs etc.) are used with the spare part.
See under number key for assembly parts

Dazu:

Angabe von Montierungsteilen (Schrauben, Muttern, Scheiben usw.) die zusammen mit dem Ersatzteil angewendet werden sollen. Siehe Nummernschlüssel für Montagezubehör.

Pour ceci:

Indique lesquelles et combien de pièces de montage (vis, écrous, rondelles etc.) sont employées avec la pièce de rechange. Voir dans la liste de numéros pour pièces de montage.

Hertil:

Angiver hvilke og hvor mange monteringsdele (skruer, møtrikker, skiver osv.) der anvendes sammen med reservedelen. Se under nummernøgle for monteringsdele.

GXS-0002/1 NUMMERNØGLE FOR MONTERINGSDELE - NUMMERSLØSSEL FØR MONTAGEZUBEHØR
 NUMBER KEY FOR ASSEMBLY PARTS - LISTE DE PIÈCES DE MONTAGE

GXS-0002/1 NUMMERNØGLE FOR MONTERINGSDELE - NUMMERSLØSSEL FØR MONTAGEZUBEHØR
 NUMBER KEY FOR ASSEMBLY PARTS - LISTE DE PIÈCES DE MONTAGE

VARENUMMER	BENØVNELSE	BEZEICHNUNG	DESIGNATION
0602140	FJEDERBOLT 12X80/95	FEDERSTECKBOLZEN 12X80/95	SAFETY PIN
1213-2126	STÅLSÆTSKRUE M8-15	ST. SETSCHRAUBE M8-15	STEEL SET SCREW M8-15
1213-2222	STÅLSÆTSKRUE M8-20	ST. SETSCHRAUBE M8-20	STEEL SET SCREW M8-20
1213-2224	STÅLSÆTSKRUE M8-25	ST. SETSCHRAUBE M8-25	STEEL SET SCREW M8-25
1213-3126	STÅLSÆTSKRUE M10-16	ST. SETSCHRAUBE M10-16	STEEL SET SCREW M10-16
1213-3222	STÅLSÆTSKRUE M10-20	ST. SETSCHRAUBE M10-20	STEEL SET SCREW M10-20
1213-3224	STÅLSÆTSKRUE M10-25	ST. SETSCHRAUBE M10-25	STEEL SET SCREW M10-25
1213-3322	STÅLSÆTSKRUE M10-30	ST. SETSCHRAUBE M10-30	STEEL SET SCREW M10-30
1213-3622	STÅLSÆTSKRUE M10-60	ST. SETSCHRAUBE M10-60	STEEL SET SCREW M10-60
1213-4224	STÅLSÆTSKRUE M12-25	ST. SETSCHRAUBE M12-25	STEEL SET SCREW M12-25
1213-4322	STÅLSÆTSKRUE M12-30	ST. SETSCHRAUBE M12-30	STEEL SET SCREW M12-30
1213-4323	STÅLSÆTSKRUE M12-35	ST. SETSCHRAUBE M12-35	STEEL SET SCREW M12-35
1213-4324	STÅLSÆTSKRUE M12-35	ST. SETSCHRAUBE M12-35	STEEL SET SCREW M12-35
1213-4327	STÅLSÆTSKRUE M12-35 KVAL 10.9	ST. SETSCHRAUBE M12-35 Q 10.9	STEEL SET SCREW M12-35 Q 10.9
1213-4424	STÅLSÆTSKRUE M12-45	ST. SETSCHRAUBE M12-45	STEEL SET SCREW M12-45
1213-4622	STÅLSÆTSKRUE M12-60	ST. SETSCHRAUBE M12-60	STEEL SET SCREW M12-60
1213-5422	STÅLSÆTSKRUE M16-40	ST. SETSCHRAUBE M16-40	STEEL SET SCREW M16-40
1213-6323	STÅLSÆTSKRUE M20-35	ST. SETSCHRAUBE M20-35	STEEL SET SCREW M20-35
1213-6422	STÅLSÆTSKRUE M20-40	ST. SETSCHRAUBE M20-40	STEEL SET SCREW M20-40
1214-1126	STÅLSÆTSKRUE M6-45 GALV.	STAHLSCHEIBE M6-45 GALV.	STEEL SET SCREW M6-45 GALV.
1214-2122	STÅLSKRUE M8-35	STAHLSECHSKANTSCHRAUBE M8-35	STEEL SCREW M8-35
1214-2126	STÅLSKRUE M8-45	STAHLSECHSKANTSCHRAUBE M8-45	STEEL SCREW M8-45
1214-2226	STÅLSKRUE M8-60	STAHLSECHSKANTSCHRAUBE M8-60	STEEL SCREW M8-60
1214-2228	STÅLSKRUE M8-65	STAHLSECHSKANTSCHRAUBE M8-65	STEEL SCREW M8-65
1214-3122	STÅLSKRUE M10-45	STAHLSECHSKANTSCHRAUBE M10-45	STEEL SCREW M10-45
1214-3228	STÅLSKRUE M10-65 KV. 8.8	STAHLSECHSKANTSCHR. M10-65 Q 8.8	STEEL SCHREW M10-65 Q 8.8
1214-3422	STÅLSKRUE M10-100	STAHLSECHSKANTSCHRAUBE M10-100	STEEL SCREW M10-100
1214-4228	STÅLSKRUE M12-65 KV. 10.9	STAHLSCHEIBE M12-65 Q 10.9	STEEL SCREW M12-65 Q. 10.9
1214-4430	STÅLSÆTSKRUE M12-140	STAHLSCHEIBE M12-140	STEEL SET SCREW M12-140
1215-2222	BREDDESKRUE M8-20	FLACHRUNDSCHRAUBE M8-20	CARRIAGE SCREW M8-20
1215-2224	BREDDESKRUE M8-25	FLACHRUNDSCHRAUBE M8-25	CARRIAGE SCREW M8-25
1215-3226	BREDDESKRUE M10-25 KVAL. 8.8	FLACHRUNDSCHRAUBE M10-25 Q 8.8	CARRIAGE SCREW M10-25 Q 8.8
1215-3228	BREDDESKRUE M10-20 KV 8.8	FLACHRUNDSCHRAUBE M10-20 Q 8.8	CARRIAGE SCREW M10-20 Q 8.8
1215-3320	BREDDESKRUE M10-30 KV 8.8	FLACHRUNDSCHRAUBE M10-30 Q 8.8	CARRIAGE SCREW M10-30 Q 8.8
1215-4220	BREDDESKRUE M12-25 KV. 8.8	FLACHRUNDSCHRAUBE M12-25 Q 8.8	CARRIAGE SCREW M12-25 Q. 8.8
1216-1156	MASKINSKRUE R/H M5-15	ZYLINDERSCHRAUBE M5-15	MACHINE SCREW ROUNDH. M5-15
1219-0210	SKRUE M10-30 12.9 DELTA B	SCHRAUBE M10-30 12.9 DELTA B	SCREW M10-30 12.9 DELTA B
1219-0217	UNBRACOSKRUE M8-20 MSP	INNENSECHSK. M8-20 MSP	ALLEN SCREW M8-20 MSP
1219-0245	UNBRACOSKRUE M12-30 MC	INNENSECHSK. SCHR. M12-30 MC	ALLEN SCREW M12-30 MC
1219-0266	UNBRACOSKRUE M10-30	INNENSECHSKANTSCHRAUBE M10-30	ALLEN SCREW M10-30
1219-0290	SKRUE CH M12-35	SCHRAUBE M12-35	SCREW CH M12-35
1219-0345	SKRUE CH M6-40	SCHRAUBE CH M6-40	SCREW CH M6-40
1219-0404	ØJEBOLT M10-17	AUGENBOLZEN M10-17	EYE BOLT M10-17
1219-0599	SELVSKERENDE SKRUE M6-20/M6SF	SCHRAUBE M6-40/M6SF	SCREW M6-40/M6SF
1219-0926	U-BOLT HRD	U-BOLZEN HRD	U-BOLT HRD
1220-1322	NYLOC MØTRIK M5	NYLOC MUTTER M5	NYLOC NUT M5
1220-1323	NYLOC MØTRIK M6	NYLOC MUTTER M6	NYLOC NUT M6
1220-2122	STÅLMØTRIK M8	STAHLMUTTER M8	STEEL NUT M8
1220-2321	NYLOC MØTRIK M8	NYLOC MUTTER M8	NYLOC NUT M8
1220-3122	STÅLMØTRIK M10	STAHLMUTTER M10	STEEL NUT M10
1220-3321	NYLOC MØTRIK M10	NYLOC MUTTER M10	NYLOC NUT M10
1220-3323	NYLOC MØTRIK M10 KVAL 10.9	NYLOC MUTTER M10 Q. 10.9	NYLOC NUT M10 Q. 10.9
1220-3922	MØTRIK M10	MUTTER M10	NUT M10
1220-4122	STÅLMØTRIK M12	STAHLMUTTER M12	STEEL NUT M12
1220-4321	NYLOC MØTRIK M12	NYLOC MUTTER M12	NYLOC NUT M12
1220-4323	NYLOC MØTRIK M12 KV 10	NYLOC MUTTER M12 Q 10	NYLOC NUT M12 Q 10
1220-5321	NYLOC MØTRIK M16	NYLOC MUTTER M16	NYLOC NUT M16
1220-6122	STÅLMØTRIK M20	STAHLMUTTER M20	STEEL NUT M20
1220-6321	NYLOC MØTRIK M20	NYLOC MUTTER M20	NYLOC NUT M20
1241-1202	SPÆNDESKIVE 8,4-16-1,6	SCHEIBE 8,4-16-1,6	WASHER 8,4-16-1,6
1241-1206	SPÆNDESKIVE 6,4-18-1,6	SCHEIBE 6,4-18-1,6	WASHER 6,4-18-1,6
1241-1207	SPÆNDESKIVE 6,4-12-1,6	SCHEIBE 6,4-12-1,6	WASHER 6,4-12-1,6
1241-1304	SPÆNDESKIVE 8-22-1,5	SCHEIBE 8-22-1,5	WASHER 8-22-1,5
1241-1402	SKIVE	SCHEIBE	WASHER
1241-1405	SPÆNDESKIVE R5,5-18-2	SCHEIBE R5,5-18-2	WASHER R5,5-18-2
1241-1502	SPÆNDESKIVE 8,5-30-3	SCHEIBE 8,5-30-3	WASHER 8,5-30-3
1241-2401	SPÆNDESKIVE 11-20-2,5	SCHEIBE 11-20-2,5	WASHER 11-20-2,5
1241-2402	SPÆNDESKIVE 10,5-20-2,0	SCHEIBE 10,5-20-2,0	WASHER 10,5-20-2,0
1241-2404	SPÆNDESKIVE 10-36-2	SCHEIBE 10-36-2	WASHER 10-36-2
1241-2502	SPÆNDESKIVE 10,5-22-3	SCHEIBE 10,5-22-3	WASHER 10,5-22-3
1241-2505	SPÆNDESKIVE 12,5-32-3	SCHEIBE 12,5-32-3	WASHER 12,5-32-3
1241-2507	SPÆNDESKIVE 13-29-3	SCHEIBE 13-29-3	WASHER 13-29-3
1241-2603	SPÆNDESKIVE 10,5-25-4	SCHEIBE 10,5-25-4	WASHER 10,5-25-4
1241-3402	SPÆNDESKIVE 14-40-2	SCHEIBE 14-40-2	WASHER 14-40-2
1241-3403	SPÆNDESKIVE 13-25-2,5	SCHEIBE 13-25-2,5	WASHER 13-25-2,5
1241-3502	SPÆNDESKIVE 13-42-3	SCHEIBE 13-42-3	WASHER 13-42-3
1241-4502	SPÆNDESKIVE 17-30-3 STÅL	SCHEIBE 17-30-3 STAHL	WASHER 17-30-3 STEEL
1241-6502	SPÆNDESKIVE	SCHEIBE	WASHER
1241-6702	SPÆNDESKIVE 29-42-5	SCHEIBE 29-42-5	WASHER 29-42-5
1241-7601	SPÆNDESKIVE 30-56-4	SCHEIBE 30-56-4	WASHER 30-56-4
1241-7802	SPÆNDESKIVE 37-52-6	SCHEIBE 37-52-6	WASHER 37-52-6
1241-8705	SPÆNDESKIVE 36-60-5	SCHEIBE 36-60-5	WASHER 36-60-5

VARENUMMER	BENØVNELSE	BEZEICHNUNG	DESIGNATION
1241-8907	SPÆNDESKIVE	SCHEIBE	WASHER
1241-9982	SPECIALSKIVE	SONDERSSCHEIBE	SPECIAL WASHER
1251-3501	SPÆNDESTIFT 5-60	SPANNSTIFT 5-60	SPECIAL PIN 5-60
1251-3503	SPÆNDESTIFT 5,0-60	SPANNSTIFT 5,0-60	SPECIAL PIN 5,0-60
1251-5305	SPÆNDESTIFT 8,0-40	SPANNSTIFT 8,0-40	SPECIAL PIN 8,0-40
1251-5401	SPÆNDESTIFT 7-50	SPANNSTIFT 7-50	SPECIAL PIN 7-50
1251-5503	SPÆNDESTIFT 8-60	SPANNSTIFT 8-60	SPECIAL PIN 8-60
1251-5703	SPÆNDESTIFT 8,0-80	SPANNSTIFT 8,0-80	SPECIAL PIN 8,0-80
1251-6506	SPÆNDESTIFT 9-60	SPANNSTIFT 9-60	SPECIAL PIN 9-60
1251-7406	SPÆNDESTIFT 12-50	SPANNSTIFT 12-50	SPECIAL PIN 12-50
1251-7501	SPÆNDESTIFT 12-60	SPANNSTIFT 12-60	SPECIAL PIN 12-60
1251-8501	SPÆNDESTIFT 14-60	SPANNSTIFT 14-60	SPECIAL PIN 14-60
1251-8601	SPÆNDESTIFT 14-70	SPANNSTIFT 14-70	SPECIAL PIN 14-70
1252-3102	SPLIT 4-25	SPLINT 4-25	COTTER PIN 4-25
1254-4201	SKRINGSSPLIT 10 MM	FEDERSPLINT 10 MM	SECURING PIN 10 MM
1311-8600	TOPPLADE	TOPPLATTE	TOP PLATE
1313-1101	SMØRENIPEL	SCHMIERNIPPEL	GREASE NIPPLE
1393-0105	GUMMI-DUPSKO	GUMMISPITZE	RUBBER TIP
1399-0379	KUGLEKNOP	KUGELHAGEN	BALL HOOK

FIGURNØGLE - FIGURSCHLÜSSEL - FIGURE KEY - LISTE DE FIGURES

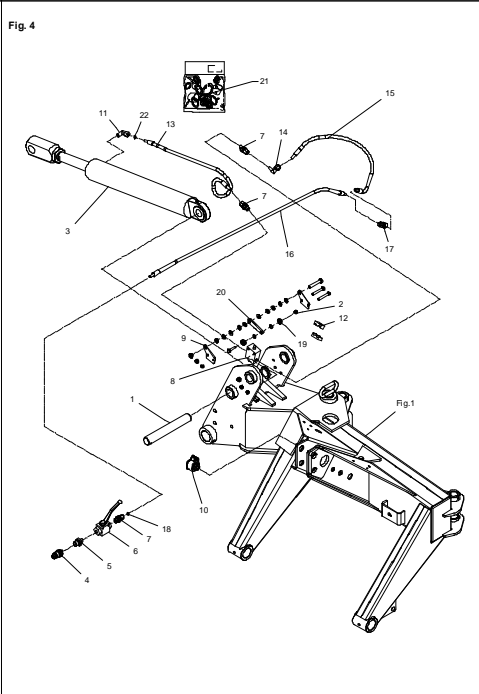
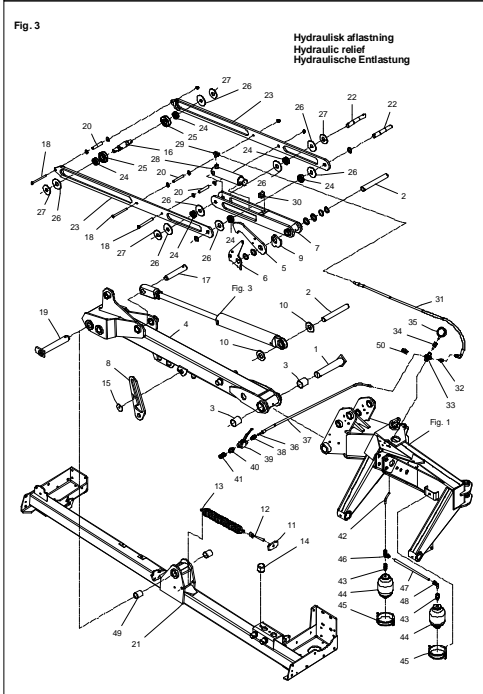
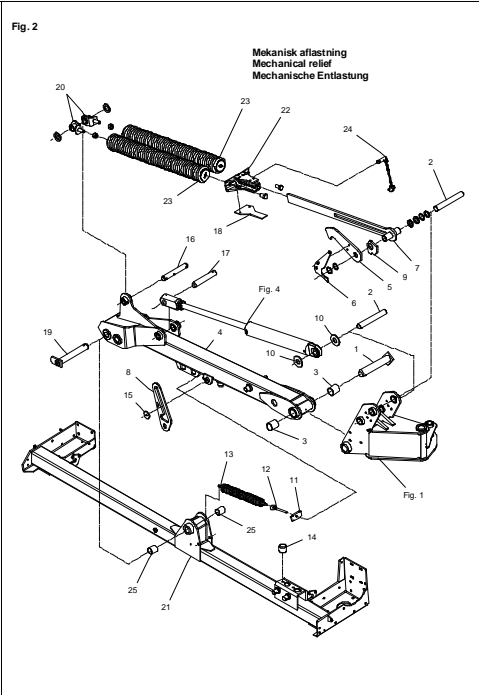
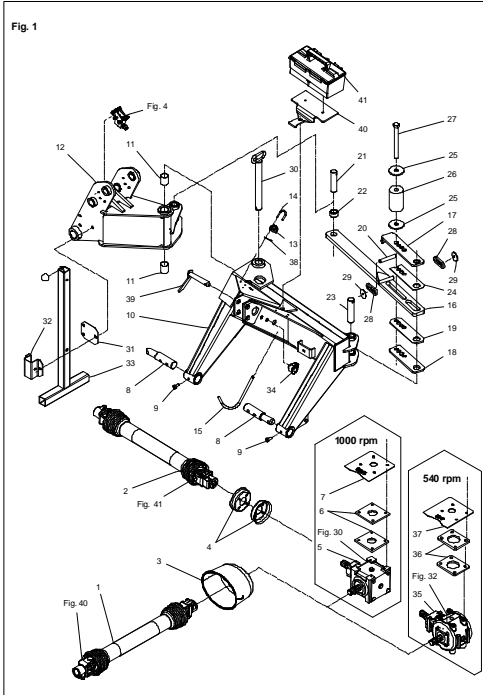

FIGURNØGLE - FIGURSCHLÜSSEL - FIGURE KEY - LISTE DE FIGURES

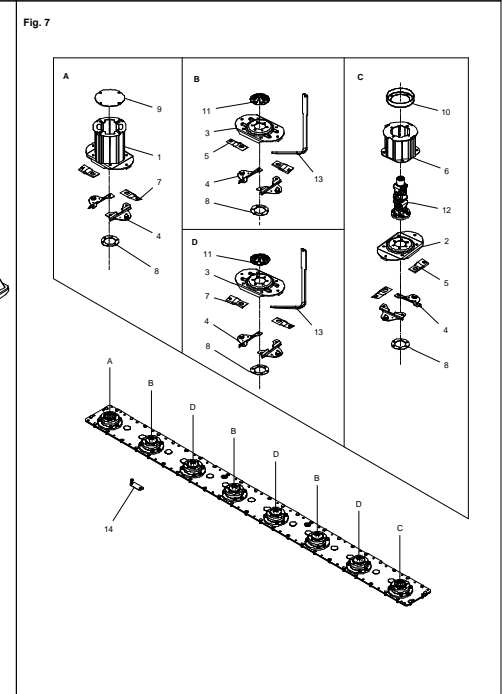
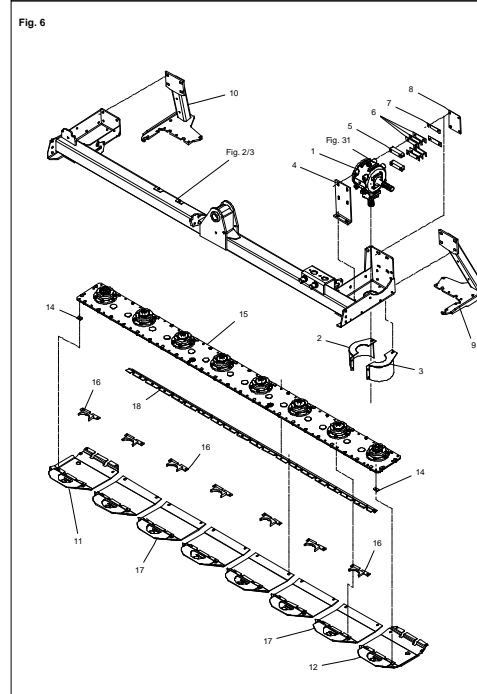
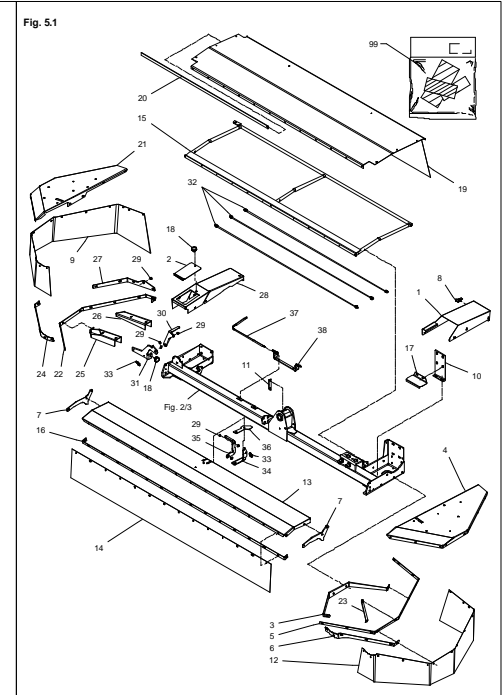
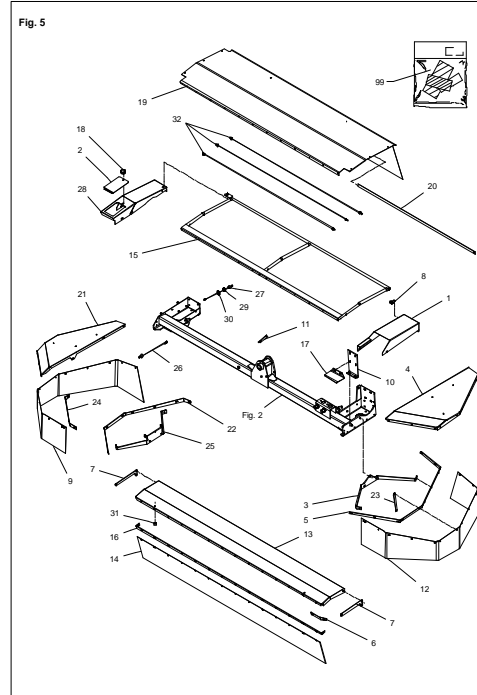

FIGURNØGLE - FIGURSCHLÜSSEL - FIGURE KEY - LISTE DE FIGURES

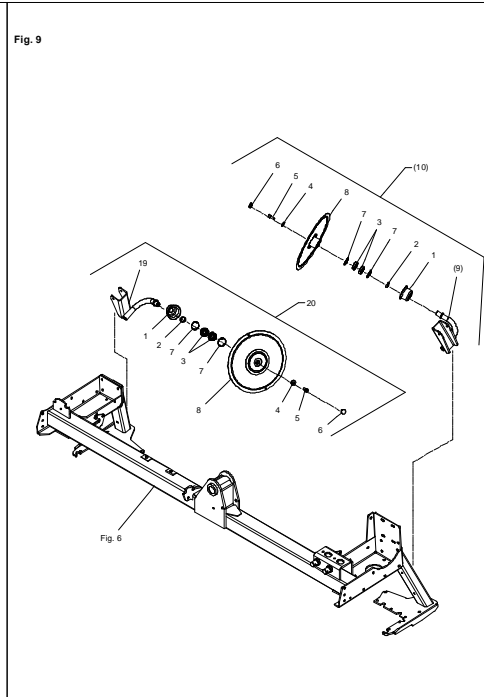
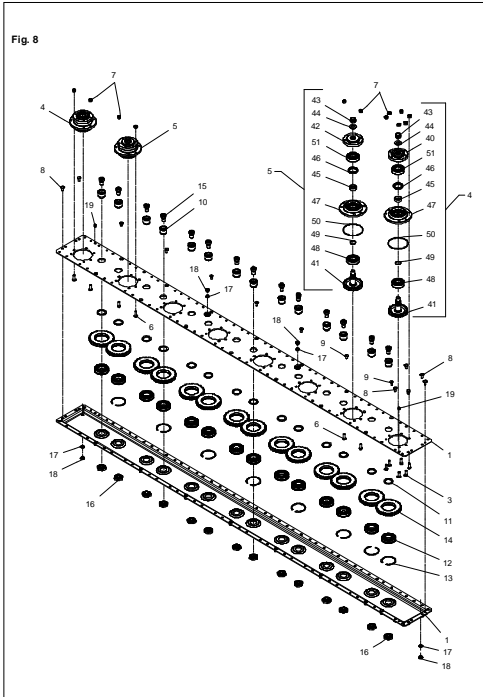

FIGURNØGLE - FIGURSCHLÜSSEL - FIGURE KEY - LISTE DE FIGURES

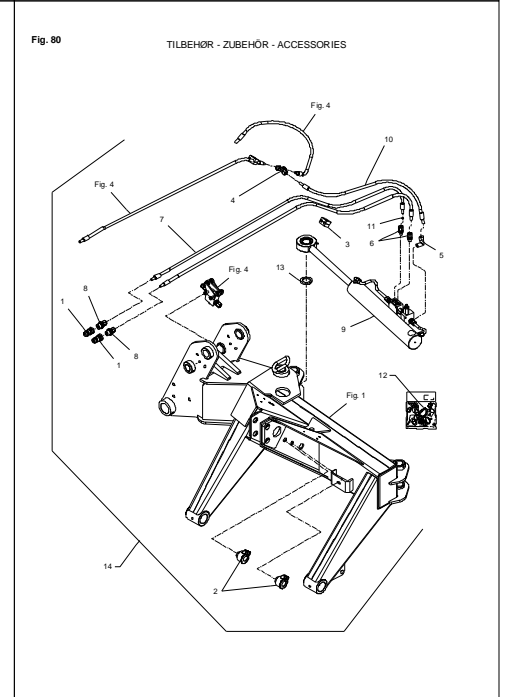
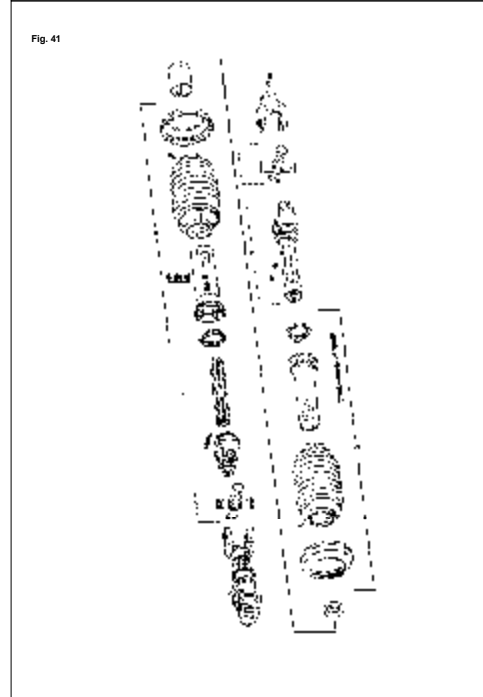
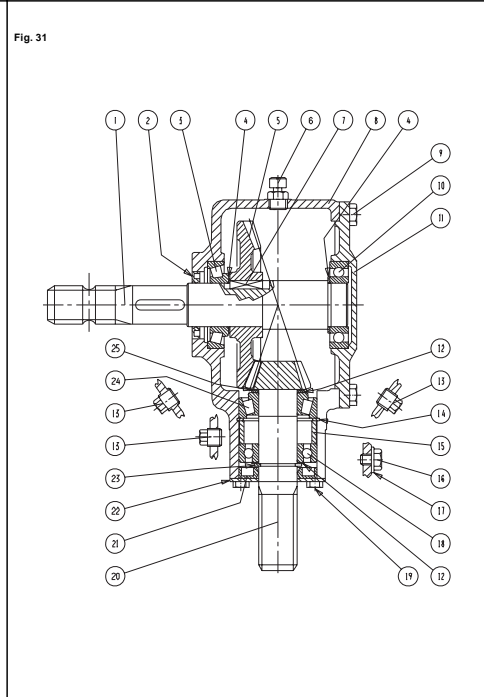
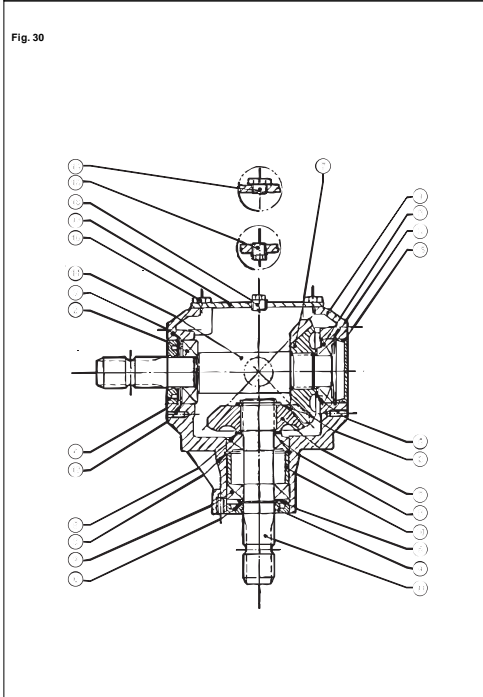
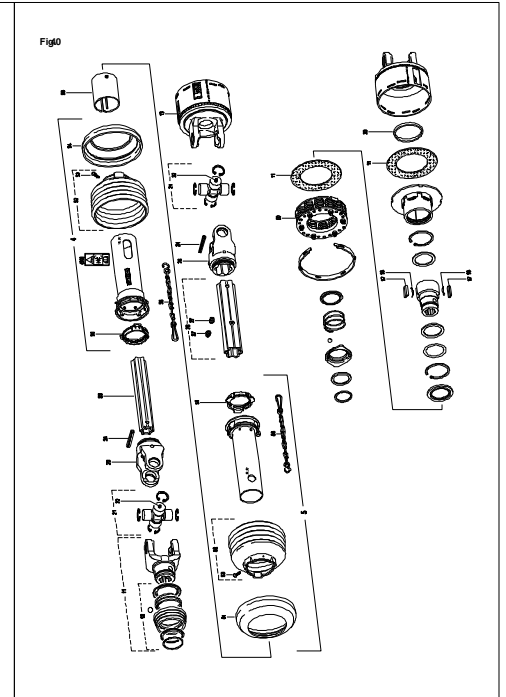
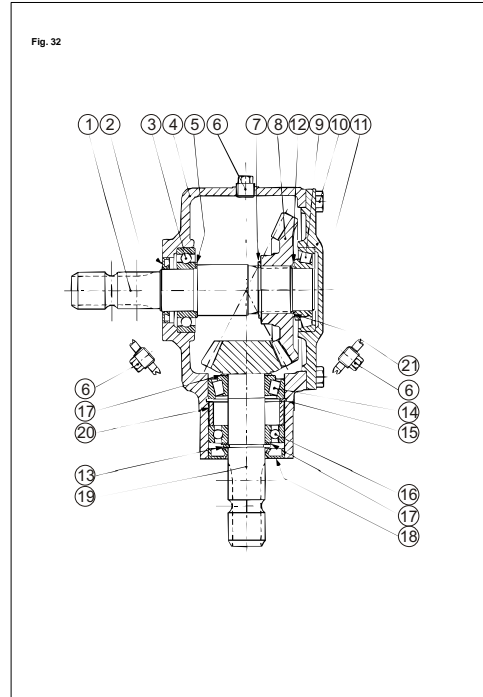

FIGURNØGLE - FIGURSCHLÜSSEL - FIGURE KEY - LISTE DE FIGURES

Fig. 81

TILBEHØR - ZUBEHÖR - ACCESSORIES

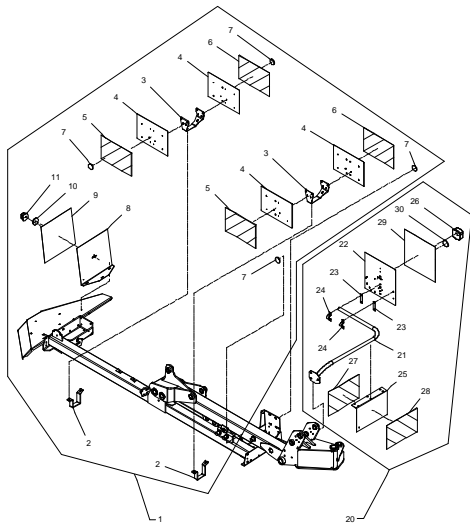

Fig. 82

TILBEHØR - ZUBEHÖR - ACCESSORIES

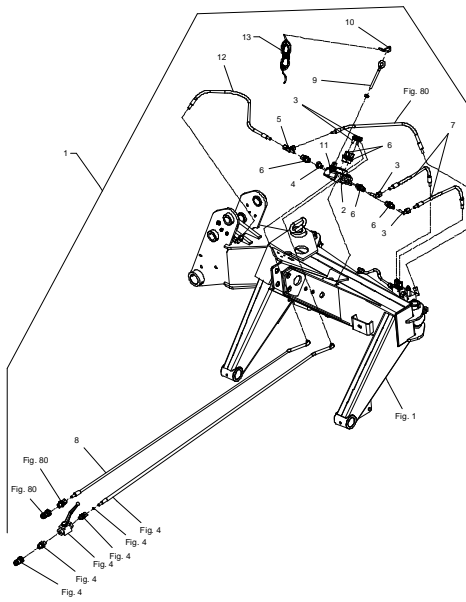
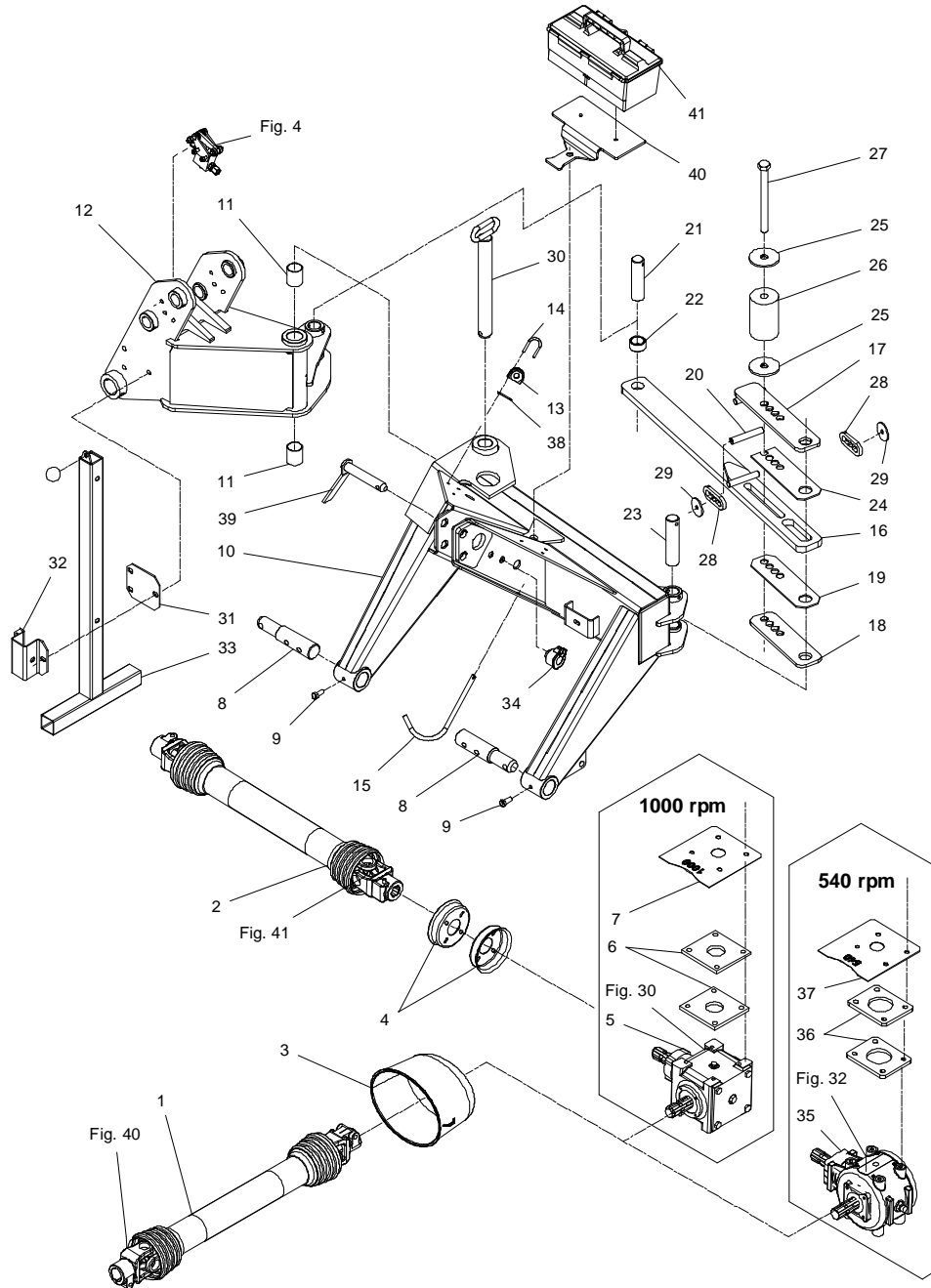

Fig. 1



GXS-0002/1 GXS 3205

FIG. 1.

>=2840101401

HERTIL, DAZU,
TO THIS, A CECI

POS.	VARENUMMER	ANTAL	BENEVNELSE	BEZEICHNUNG	DESIGNATION			
1.	1340-5117	1	KRAFTOVERFØRINGSAKSEL GELENKWELLE		PTO SHAFT			
2.	1340-5116	1	KRAFTOVERFØRINGSAKSEL GELENKWELLE		PTO SHAFT			
3.	1393-0174	1	PTO-SKÆRM, OVAL PTO-SCHUTZ, OVAL		PTO-GUARD, OVAL	1213-2126	4	
						1241-1502	4	
4.	3225-596X	2	HOLDER HALTER		HOLDER	1213-2126	4	
						1241-1502	4	
5.	3010-608X	1	VINKELTRÆK 1000 O/M WINKELGETRIEBE 1000 U/M		BEVEL GEAR 1000 RPM	1213-4424	4	
						1241-9982	4	
6.	2225-117X	2	UNDERLAG UNTERLAGE		SUPPORT			
7.	2322-133X	1	SPÆNDEPLADE SPANNPLATTE		RETAINING PLATE			
8.	2087-575X	2	TAP, KAT. III ZAPPEN, KAT. III		DOWEL, KAT. III			
9.	2184-229X	2	BOLT BOLZEN		BOLT	1220-4122	1	
10.	3365-500X	1	TOPRAMME ZUGRAHMEN		TOP FRAME			
11.	1335-4401	2	GLACIERLEJE 44-40-50 GLISSALAGER 44-40-50		BEARING GLISSA 44-40-50			
12.	3321-800X	1	DREJEKONSOL DREHKONSOLE		ROTARY BRACKET			
13.	2365-366X	1	PORCELENSØJE PORZELAN OESE		PORCELAIN EYE			
14.	2365-367X	1	BØJLESKRUE SCHRAUBE		SCREW	1220-1323	2	
						1241-1207	2	
15.	2223-220X	1	BØJLE BUEGEL		HOOP	1241-3402	1	
						1252-3102	1	
16.	3322-101X	1	STENDLØSER STEINE AUSLØSER		STONE RELEASE			
17.	3322-105X	1	LÅS SCHLOSS		LOCK			
18.	2322-111X	1	SPÆNDEPLADE SPANNPLATTE		RETAINING PLATE			
19.	2322-112X	1	GLIDER GLEITER		SLEEVE			
20.	2322-113X	1	RULLE ROLLE		ROLLER			
21.	2365-093X	1	TAP ZAPPEN		DOWEL	1241-7802	1	
						1251-6506	1	
22.	2365-198X	1	BØSNING BUCHSE		BUSH			
23.	2365-094X	1	TAP ZAPPEN		DOWEL	1251-3503	1	
						1251-6506	1	
24.	2322-110X	1	GLIDER GLEITER		SLEEVE			
25.	2322-118X	2	SKIVE SCHEIBE		WASHER	1213-3222	1	
26.	1393-0196	1	ELASTOMERFJEDER ELASTOMERFEDER		RUBBER SPRING			
27.	1214-6630	1	STÅLSKRUE M20-220 STAHLSECHSKANTSCHRAUBE M20-220		STEEL SCREW M20-220	1220-6321	1	

Fig. 1

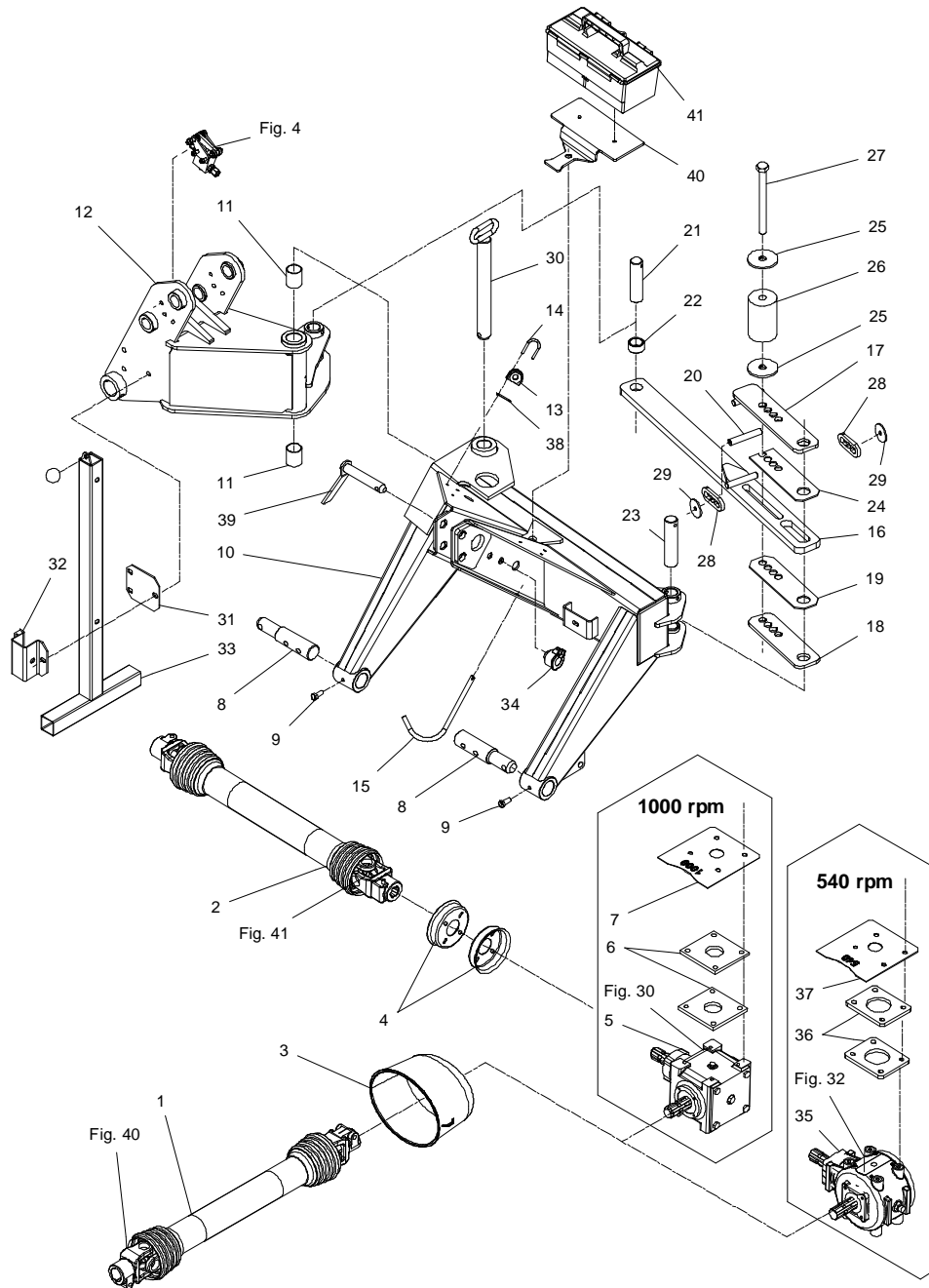

GXS-0002/1 GXS 3205

FIG. 1.

>=2840101401

HERTIL, DAZU,
TO THIS, A CECI

POS.	VARENUMMER	ANTAL	BENEVNELSE	BEZEICHNUNG	DESIGNATION		
28.	2322-117X	2	RULLEFØRING ROLLENFUHRUNG		ROLLER GUIDE		
29.	2365-893X	2	SKIVE SCHEIBE		WASHER	1213-3222	1
30.	3322-166X	1	TAP MED KØDELED ZAPPEN MIT KETTENGLIED		DOWEL WITH CHAIN LINK	1251-5503 1251-8501	2 2
31.	2322-164X	1	PLADE BLECH		PLATE		
32.	2322-163X	1	STØTTEBENSHOLDER ABSTELLSTÜTZEHALTER		JACK SUPPORT	1213-6323 1220-4321 1241-3403	3 3 3
33.	3322-160X	1	STØTTEBEN ABSTELLSTUTZE		JACK	0602140 1213-3322 1220-3122 1399-0379	1 1 1 1
34.	1317-1016	1	STIK-HOLDER STECKERHALTER		PLUG HOLDER		
35.	3010-605C	1	VINKELTRÆK 540 RPM WINKELGETRIEBE 540 RPM		BEVEL GEAR 540 RPM	1213-4323 1241-9982	4 4
36.	2322-139X	2	UNDERLAG UNTERLAGE		SUPPORT		
37.	2322-134X	1	SPENDEPLADE SPANNPLATTE		RETAINING PLATE		
38.	2365-404X	1	UNDERLAG ZWISCHENLAGE		INTERMEDIATE PLATE		
39.	1399-0128	1	TAP ZAPPEN		DOWEL		
40.	2322-187X	1	BESLAG BESCHLAG		FITTINGS	1213-2224 1213-5422 1220-2321 1220-5321 1241-1402 1241-4502	2 1 2 1 4 1
41.	1399-0390	1	VERKTØJSKASSE WERKZEUGKASTEN		TOOL BOX		

Fig. 2

Mekanisk aflastning
Mechanical relief
Mechanische Entlastung

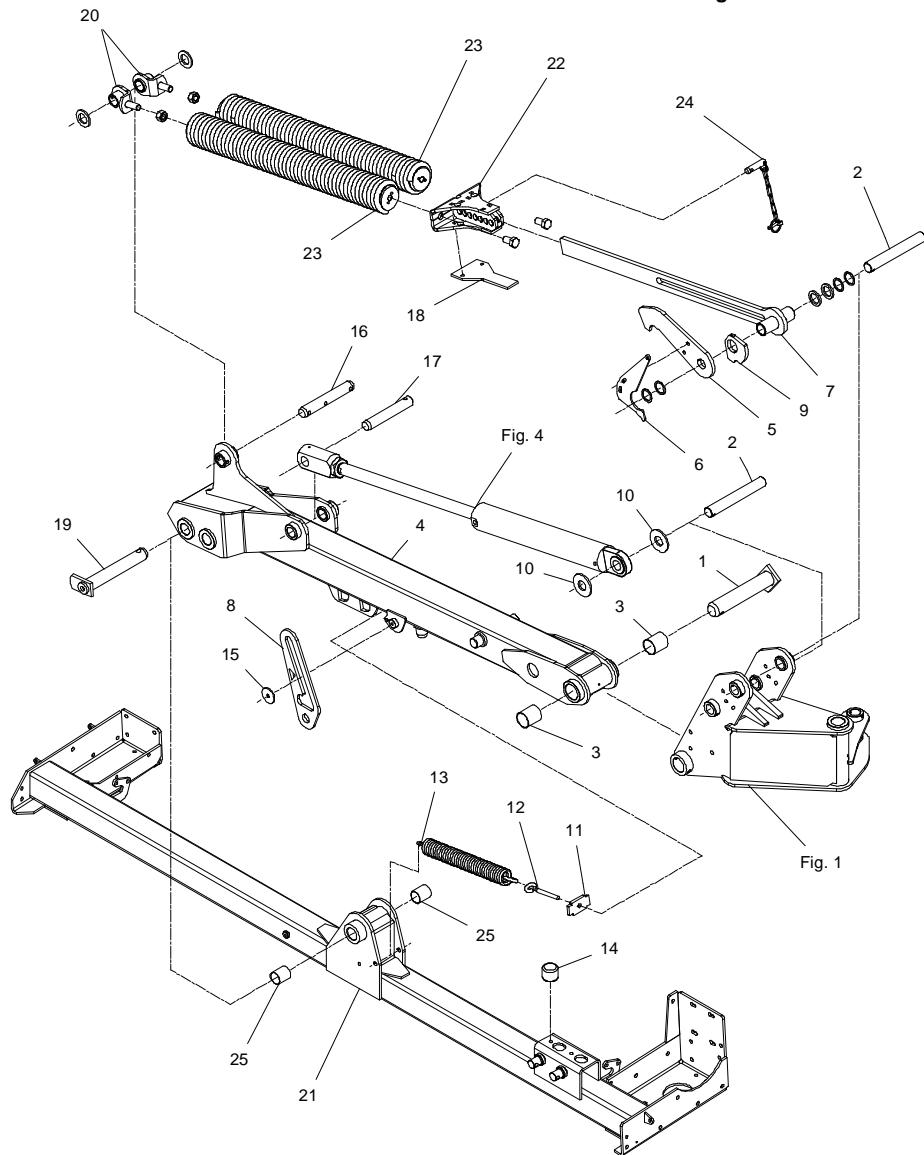

GXS-0002/1 GXS 3205

FIG. 2.

>=2840101401

HERTIL, DAZU,
TO THIS, A CECI

POS.	VARENUMMER	ANTAL	BENÆVNELSE	BEZEICHNUNG	DESIGNATION		
1.	3325-656X	1	TAP ZAPFEN		DOWEL	1251-5703	1
						1251-8601	1
2.	2365-445X	2	TAP ZAPFEN		DOWEL	1251-3503	1
						1251-6506	1
3.	1335-5520	2	GLACIERLEJE 55-50-60 GLISSALAGER 55-50-60		BEARING GLISSA 55-50-60		
4.	3365-830X	1	UDLIGGER AUSLEGER		SPINNAKER		
5.	2365-825X	1	KROC HAGEN		HOOK	1241-7802	3
						1241-8907	2
6.	2365-823X	1	UDLØSER AUSLØSER		RELEASE	1215-3320	2
						1220-3321	2
7.	3365-870X	1	FJEDER TRÆKSTANG FEDER ZUGSTANGE		SPRING DRAWBAR	1313-1101	1
8.	2365-842X	1	LÅS SCHLOSS		LOCK	1241-7601	1
						1251-7501	1
						1254-4201	1
9.	2321-866X	1	KURVESTYR FÜHRUNGSPLATTE		STEERING PLATE	1213-2224	1
						1219-0217	1
10.	2365-625X	2	SKIVE SCHEIBE		WASHER		
11.	2365-854X	1	BESLAG BESCHLAG		SUPPORT	1214-4430	1
						1220-4321	2
						1241-3403	3
12.	1392-0110	1	ØJEBOLT M12-123 GALV AUGBOLZEN M12-123 GALV		EYE BOLT M12-123 GALV		
13.	1432-6698	1	TRÆKFJEDER ZUGFEDER		TENSION SPRING		
14.	1393-0110	1	GUMMIBUFFE GUMMIBUFFER		RUBBER BUFFER	1213-3224	1
						1241-2502	1
15.	2365-893X	1	SKIVE SCHEIBE		WASHER	1213-3222	1
16.	2321-979X	1	TAP ZAPFEN		DOWEL	1241-8705	2
						1251-5401	1
						1251-7406	3
17.	2322-132X	1	TAP ZAPFEN		DOWEL	1251-3503	1
						1251-6506	1
18.	2365-824X	1	GLIDEPLADE GLEITPLATTE		SLIDEPLATE	1215-3320	2
						1220-3321	2
						1241-2401	2
19.	3321-980X	1	TAP ZAPFEN		DOWEL	1251-3501	1
						1251-5503	1
						1251-8501	1
						1313-1101	1
20.	3365-877X	2	FJEDERHOLDER FEDERHALTER		SPRING SUPPORT	1220-6122	1
						1313-1101	1
21.	3322-120X	1	STEL RAHMEN		FRAME	1213-4327	8
						1220-4323	8
						1241-3403	8
						1241-3502	2
21. 1	3322-120A	1	STEL RAHMEN		FRAME		
						>=2840101628	
22.	3365-873X	1	FJEDERBESLAG FEDERBESCHLAG		SPRING BRACKET		
23.	3365-157X	2	TRÆKFJEDER KPL ZUGFEDER KPL		TENSION SPRING CPL	1213-6422	1

Fig. 2

Mekanisk aflastning
 Mechanical relief
 Mechanische Entlastung

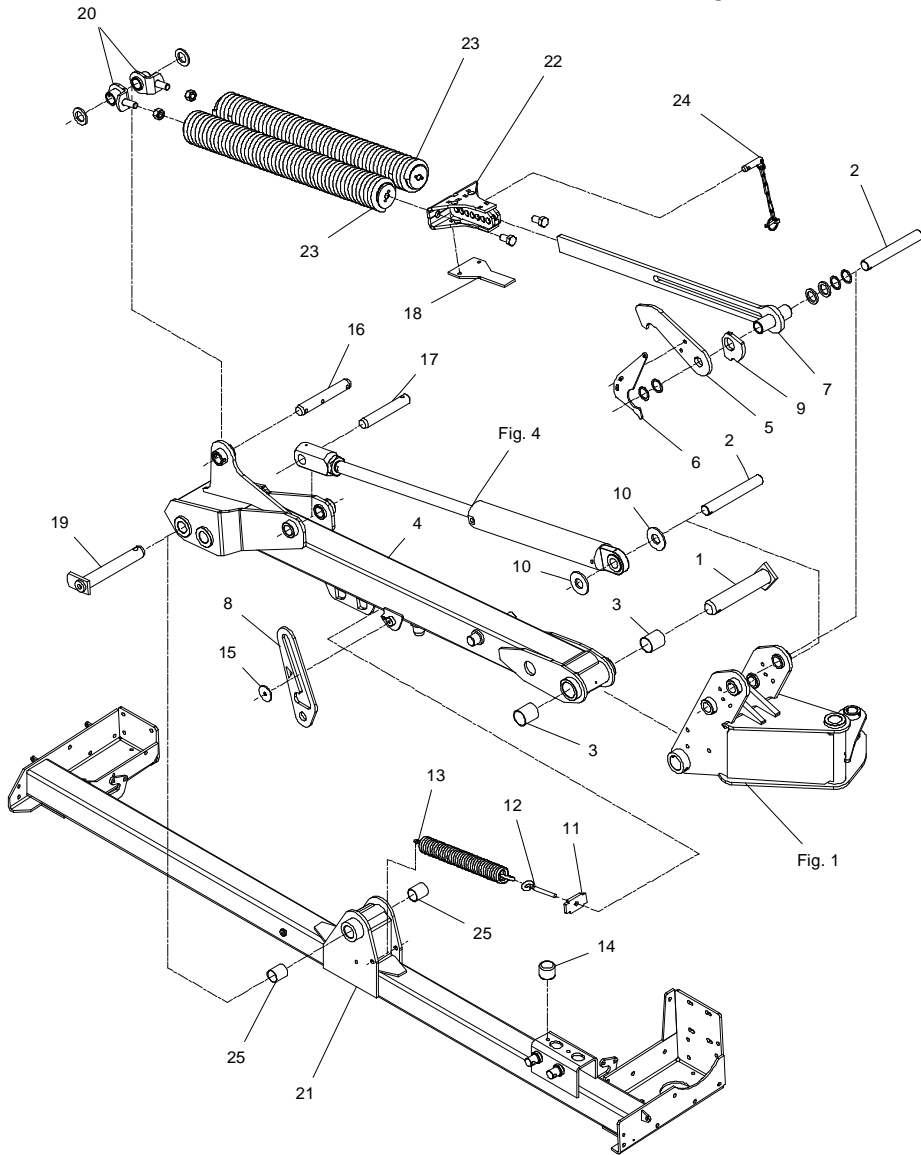

GXS-0002/1 GXS 3205

FIG. 2.

>=2840101401

HERTIL, DAZU,
 TO THIS, A CECI

POS.	VARENUMMER	ANTAL	BENÆVNELSE	BEZEICHNUNG	DESIGNATION
24.	3365-876X	1	TAP ZAPPEN		DOWEL
25.	1335-4401	2	GLACIERLEJE 44-40-50 GLISSALAGER 44-40-50		BEARING GLISSA 44-40-50

Fig. 3

Hydraulisk aflastning
Hydraulic relief
Hydraulische Entlastung

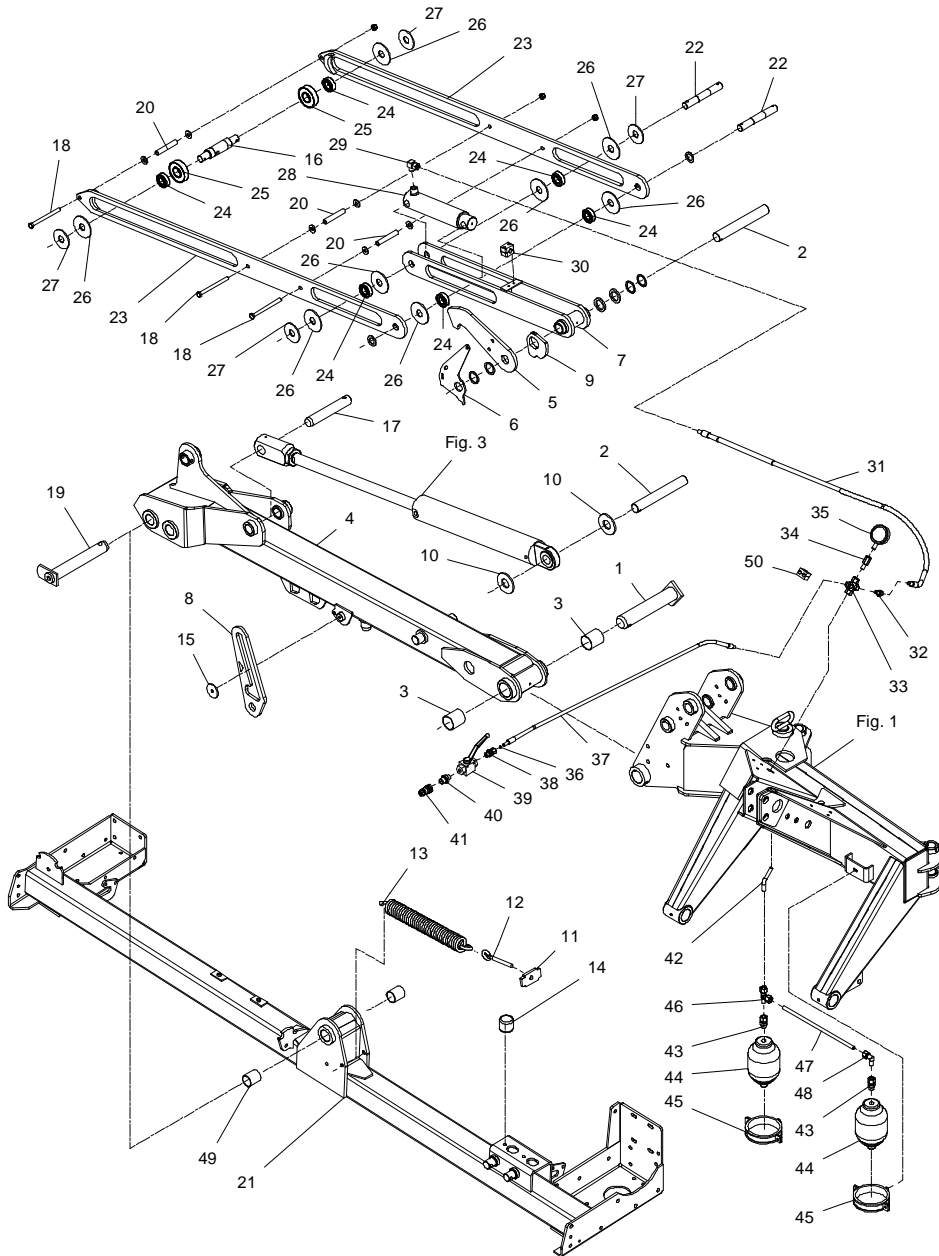

GXS-0002/1 GXS 3205

FIG. 3.

>=2840101401

HERTIL, DAZU,
TO THIS, A CECI

POS.	VARENUMMER	ANTAL	BENÆVNELSE	BEZEICHNUNG	DESIGNATION		
1.	3325-656X	1	TAP ZAPFEN		DOWEL	1251-5703 1251-8601	1 1
2.	2365-445X	2	TAP ZAPFEN		DOWEL	1251-3503 1251-6506	1 1
3.	1335-5520	2	GLACIERLEJE 55-50-60 GLISSALAGER 55-50-60		BEARING GLISSA 55-50-60		
4.	3365-830X	1	UDLIGGER AUSLEGER		SPINNAKER		
5.	2365-825X	1	KROC HAGEN		HOOK	1241-7802 1241-8907	3 2
6.	2365-823X	1	UDLØSER AUSLÖSER		RELEASE	1215-3320 1220-3321	2 2
7.	3322-201X	1	KONSOL F. CYLINDER KONSOLE F. ZYLINDER		BRACKET F. CYLINDER	1313-1101	1
8.	2365-842X	1	LÅS SCHLOSS		LOCK	1241-7601 1251-7501 1254-4201	1 1 1
9.	2321-866X	1	KURVESTYR FØHRINGSPLATTE		STEERING PLATE	1219-0217 1220-2122	1 1
10.	2365-625X	2	SKIVE SCHEIBE		WASHER		
11.	2365-854X	1	BESLAG BESCHLAG		SUPPORT	1214-4430 1220-4321 1241-3403	1 2 3
12.	1392-0110	1	ØJEBOLT M12-123 GALV AUGBOLZEN M12-123 GALV		EYE BOLT M12-123 GALV		
13.	1432-6698	1	TRÆKFJEDER ZUGFEDER		TENSION SPRING		
14.	1393-0110	1	GUMMIBUFFE GUMMIBUFFER		RUBBER BUFFER	1213-3224 1241-2502	1 1
15.	2365-893X	1	SKIVE SCHEIBE		WASHER	1213-3222	1
16.	2322-208X	1	TAP ZAPFEN		DOWEL	1251-5305	2
17.	2322-132X	1	TAP ZAPFEN		DOWEL	1251-3503 1251-6506	1 1
18.	1214-4430	3	STÅLSÆTSKRUE M12-140 STAHLSCHEIBE M12-140		STEEL SET SCREW M12-140	1220-4321 1241-2507	1 2
19.	3321-980X	1	TAP ZAPFEN		DOWEL	1251-3501 1251-5503 1251-8501 1313-1101	1 1 1 1
20.	2082-335X	3	AFSTANDSRØR ABSTANDROHR		DISTANCE TUBE		
21.	3322-120X	1	STEL RAHMEN		FRAME	1213-4327 1220-4323 1241-3403 1241-3502	8 8 8 2
21. 1	3322-120A	1	STEL RAHMEN >=2840101628		FRAME		
22.	2322-210X	2	TAP ZAPFEN		DOWEL	1241-6502 1251-5305	2 2
23.	3322-204X	2	TRÆKSTANG ZUGSTANGE		DRAWBAR		
24.	1331-4601	6	KUGLELEJE S6205 2RS1 KUGELLAGER S6205 2RS1		BALL BEARING S6205 2RS1		

Fig. 3

Hydraulisk aflastning
Hydraulic relief
Hydraulische Entlastung

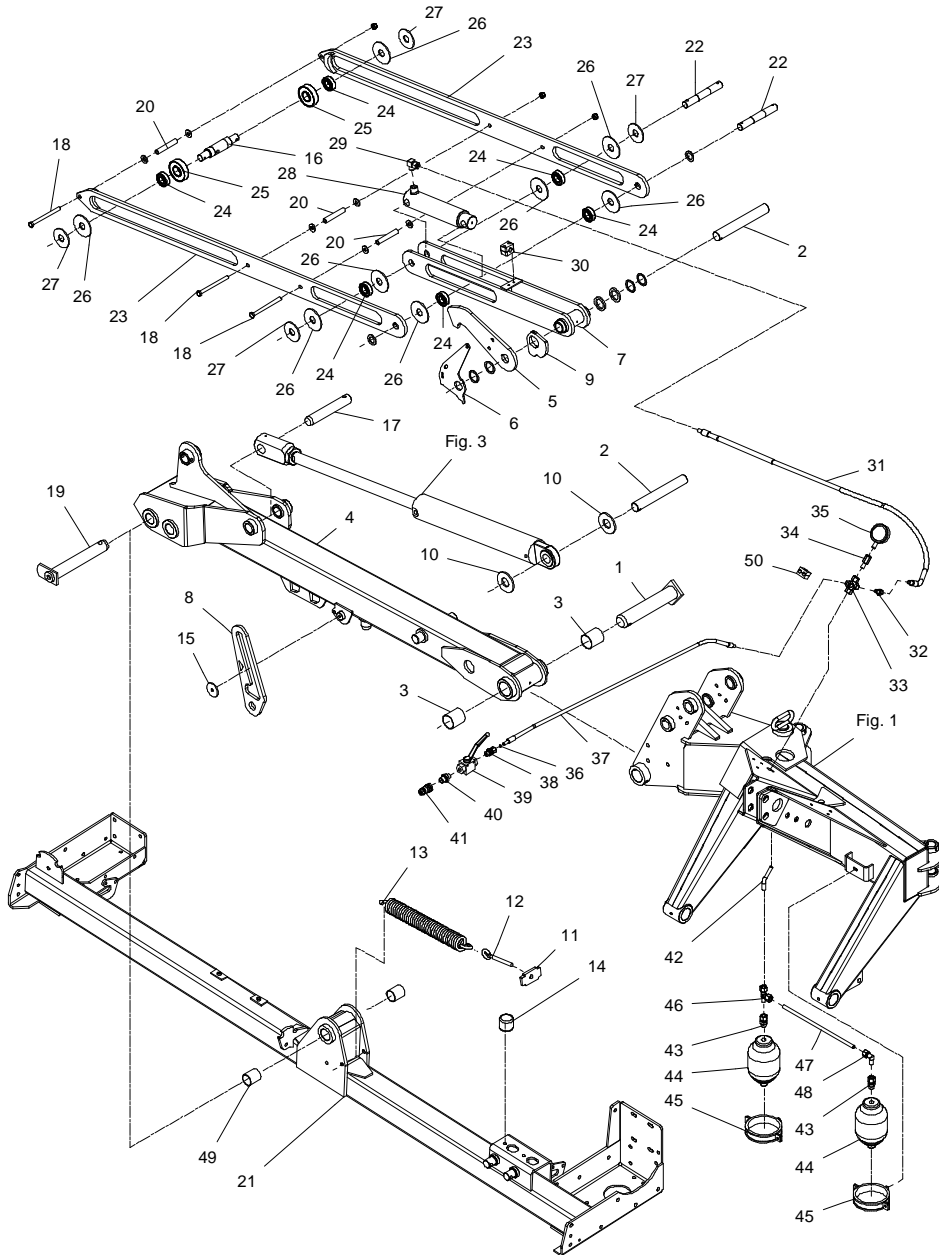

GXS-0002/1 GXS 3205

FIG. 3.

>=2840101401

HERTIL, DAZU,
 TO THIS, A CECI

POS.	VARENUMMER	ANTAL	BENØVNELSE	BEZEICHNUNG	DESIGNATION		
25.	1331-4602	2	KUGLELEJE S6307 2RS1 KUGELLAGER S6307 2RS1		BALL BEARING S6307 2RS1		
26.	2322-203X	8	PLASTSKIVE PLASTIK SCHEIBE		PLASTIC WASHER		
27.	2322-207X	4	SKIVE 75-26-4 SCHEIBE 75-26-4		WASHER 75-26-4		
28.	1317-0993	1	CYLINDER Ø50X125 EM 280 ZYLINDER Ø50X125 EM 280		CYLINDER Ø50X125 EM 280	1241-6502	4
29.	1311-6504	1	VINKELFORSKRUNING - L12 WINKELVERSCHRAUBUNG - L12		ANGLE COUPLING - L12		
30.	1311-8553	1	RØRHOLDER ROHRHALTERUNG		SUPPORT FOR TUBE	1219-0345 1220-1323	2 2
31.	1317-5012	1	SLANGE 3/8"-1800 SCHLAUCH 3/8"-1800		HOSE 3/8"-1800		
32.	1311-6503	1	VINKELFORSKRUNING WINKELVERSCHRAUBUNG		ANGLE COUPLING		
33.	1311-8516	1	KRYDSSTYKKE KREUZ		CROSS		
34.	1311-2629	1	MANOMETERTILSLUTNING DRUCK MESSER ANSCHLUSS		PRESSURE GAUGE COUPLING		
35.	1317-1008	1	MANOMETER DRUCK MESSER		PRESSURE GAUGE		
36.	2307-111X	1	DYSE DUESE		NOZZLE		
37.	1317-5011	1	SLANGE 1/4"-1500 SCHALUCH 1/4"-1500		HOSE 1/4"-1500		
38.	1311-8534	1	FORSKRUNING VERSCHRAUBUNG		SCREWED CONNECTION		
39.	1311-8533	1	KUGLEHANE KUGELHAHN		BALL TAP		
40.	1311-2304	1	BRYSTNIPPEL NIPPEL		NIPPLE		
41.	1317-0302	1	STIK F/LYNKOBLING ANSCHLUSS F/SCHNELLKUPPLUNG		CONNECTION F/QUICK-COUPLING		
42.	2322-116X	1	HYDRAULIKRØR HYDRAULIKROHR		HYDRAULIC TUBE		
43.	1311-7024	2	FORSKRUNING VERSCHRAUBUNG		SCREWED CONNECTION		
44.	1317-1030	2	AKKUMULATOR 60BAR AKKUMULATOR 60BAR		ACCUMULATOR 60BAR		
45.	1317-1013	2	RØRHOLDER ROHRHALTER		TUBE HOLDER	1213-3126 1241-2603	1 1
46.	1311-8527	2	FORSKRUNING VERSCHRAUBUNG		SCREWED CONNECTION		
47.	2322-119X	1	HYDRAULIKRØR HYDRAULIKROHR		HYDRAULIC TUBE		
48.	1311-8509	1	VINKELFORSKRUNING WINKELVERSCHRAUBUNG		ANGLE COUPLING		
49.	1335-4401	2	GLACIERLEJE 44-40-50 GLISSALAGER 44-40-50		BEARING GLISSA 44-40-50		
50.	1311-8537	1	RØRHOLDER ROHRHALTERUNG		SUPPORT FOR TUBE		

Fig. 4

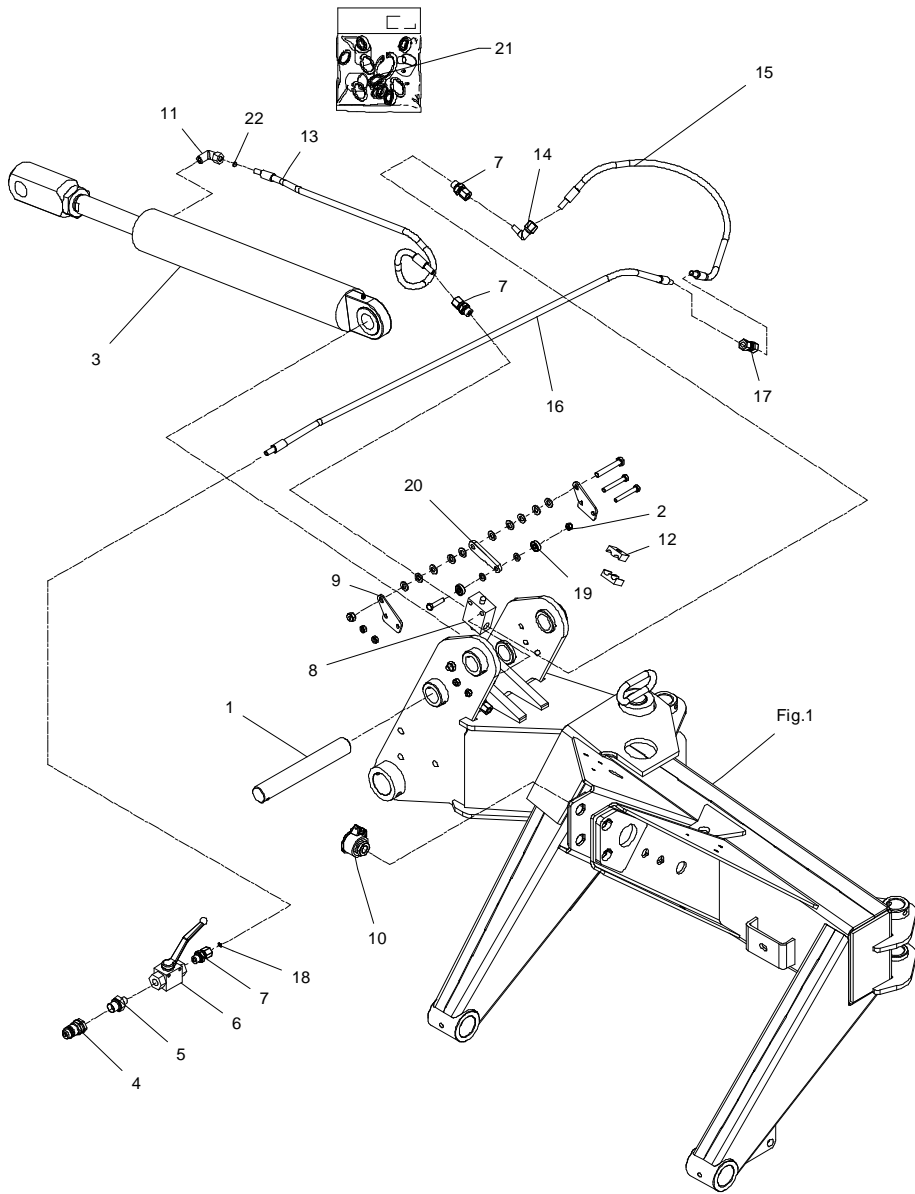

POS.	VARENUMMER	ANTAL	BENEVNELSE	BEZEICHNUNG	DESIGNATION	HERTIL, DAZU, TO THIS, A CECI
1.	2365-445X	1	TAP ZAPFEN		DOWEL	1251-3503 1 1251-6506 1
2.	1220-2321	3	NYLOC MØTRIK M8 NYLOC MUTTER M8		NYLOC NUT M8	
3.	1317-3002	1	TÆKCYLINDER ZUGZYLINDER		DRAWING CYLINDER	
4.	1317-0302	1	STIK F/LYNKOBLING ANSCHLUSS F/SCHNELLKUPPLUNG		CONNECTION F/QUICK-COUPLING	
5.	1311-2304	1	BRYSTNIPPEL NIPPEL		NIPPLE	
6.	1311-8533	1	KUGLEHANE KUGELHAHN		BALL TAP	
7.	1311-8534	3	FORSKRUNING VERSCHRAUBUNG		SCREWED CONNECTION	
8.	1317-0107	1	VENTIL VENTIL		VALVE	
9.	2321-952X	2	MONTERINGSPLADE MONTIERUNGSPLATTE		MOUNTING PLATE	1220-2321 1 1241-1202 1
10.	1317-1016	1	STIK-HOLDER STECKERHALTER		PLUG HOLDER	
11.	1311-8525	1	VINKELFORSKRUNING - L10 WINKELVERSCHRAUBUNG - L10		ANGLE COUPLING - L10	
12.	1311-8537	1	RØRHOLDER ROHRHALTERUNG		SUPPORT FOR TUBE	1214-1126 1 1220-1323 1 1311-8600 1
13.	1317-5010	1	SLANGE 1/4"-900 SCHALUCH 1/4"-900		HOSE 1/4"-900	
14.	1311-8603	1	VINKELFORSKRUNING WINKELVERSCHRAUBUNG		ANGLE COUPLING	
15.	1317-0896	1	SLANGE 1/4" L=740 SCHLAUCH 1/4" L=740		HOSE 1/4" L=740	
16.	1317-5011	1	SLANGE 1/4"-1500 SCHALUCH 1/4"-1500		HOSE 1/4"-1500	
17.	1311-8510	1	FORSKRUNING VERSCHRAUBUNG		FITTINGS	
18.	2320-676X	1	DYSE DUSE >=2840101401 <=2840101527		NOZZLE	
19.	1331-3107	2	KUGLELEJE KUGELLAGER		BALL BEARING	
20.	2321-954X	1	RULLEARM ROLLEARM		ROLLER ARM	1214-2122 1 1214-2226 2 1214-3228 1 1220-3321 1 1241-2402 10
21.	1317-9831	1	PAKINGSSET DICHTUNGSSATZ		SET OF GASKETS	
22.	2010-394X	1	DYSE DUSE >=2840101628		NOZZLE	

Fig. 5

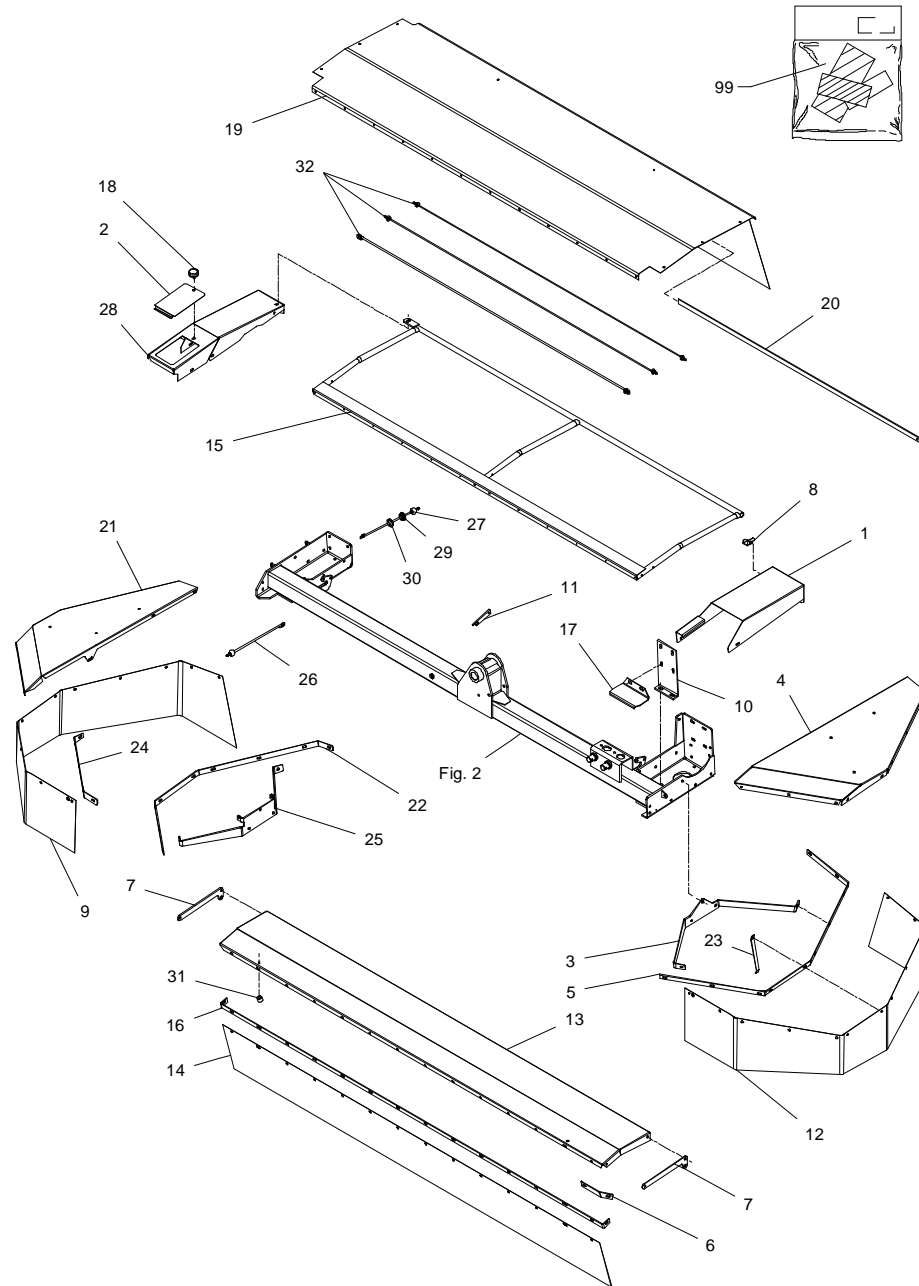

GXS-0002/1 GXS 3205

FIG. 5.

>=2840101401 <=2840101527

HERTIL, DAZU,
TO THIS, A CECI

POS.	VARENUMMER	ANTAL	BENÆVNELSE	BEZEICHNUNG	DESIGNATION		
1.	2087-850X	1	SKÆRM SCHUTZ	GUARD	1213-3322	1	
					1213-4322	2	
					1220-3321	1	
					1220-4321	2	
					1241-2502	2	
1241-3403	4						
2.	2325-336X	1	DÆKSEL DECKEL	COVER	1219-0404	1	
					1241-2404	1	
3.	2087-852X	1	SKÆRMBÆRER SCHIRMTREAGER	GUARD HOLDER			
4.	2087-833X	1	SKÆRM, VENSTRE SCHUTZ, LINKE	GUARD, LEFT	1213-4322	3	
					1220-4321	3	
					1241-2505	6	
5.	2087-851X	1	SKINNE SCHIENE	RAIL			
6.	2087-856X	1	BESLAG BESCHLAG	PLATE			
7.	2087-854X	2	BESLAG BESCHLAG	PLATE	1213-3322	3	
					1220-3321	3	
					1241-2502	6	
8.	2325-603X	1	BESLAG BESCHLAG	CLAMP	1215-2222	1	
					1220-2321	1	
					1241-2502	1	
9.	2087-860X	1	DUG, HØJRE TUCH, RECHTE	CANVAS, RIGHT	1215-3226	3	
					1215-3228	7	
					1220-3321	10	
					1241-2502	8	
10.	2325-628X	1	STIVER STÜTZE	SUPPORT	1213-4224	4	
					1213-4327	2	
					1241-3403	8	
11.	2325-335X	1	STOP STOP	STOP	1214-2126	1	
					1220-2321	1	
					1241-1202	1	
12.	2087-858X	1	DUG, VENSTRE TUCH, LINKE	CANVAS, LEFT	1215-3226	3	
					1215-3228	6	
					1220-3321	9	
					1241-2502	7	
13.	2087-843X	1	FORSKÆRM SCHUTZ, FORDERE	GUARD, FRONT			
14.	2087-859X	1	DUG, FORRESTE TUCH, VORDERE	CANVAS, FRONT	1215-3226	4	
					1215-3228	13	
					1220-3321	17	
					1241-2502	17	
15.	3325-595X	1	BØJLE BUEGEL	HOOP	1213-3322	1	
					1213-3622	3	
					1213-4622	3	
					1220-3122	3	
					1220-3321	3	
					1220-4321	3	
					1241-2404	1	
					1393-0105	2	
16.	2087-846X	1	SKINNE SCHIENE	RAIL	1213-3322	3	
					1220-3321	3	
					1241-2502	6	
17.	2087-794X	1	SKÆRM ABSCHIRMUNG	GUARD			
18.	1393-0186	1	GUMMIBUFFE GUMMIPUFFER	RUBBER BUFFER			
19.	2320-844X	1	DUG TUCH	CANVAS	1219-0599	12	
					1241-1206	12	

Fig. 5

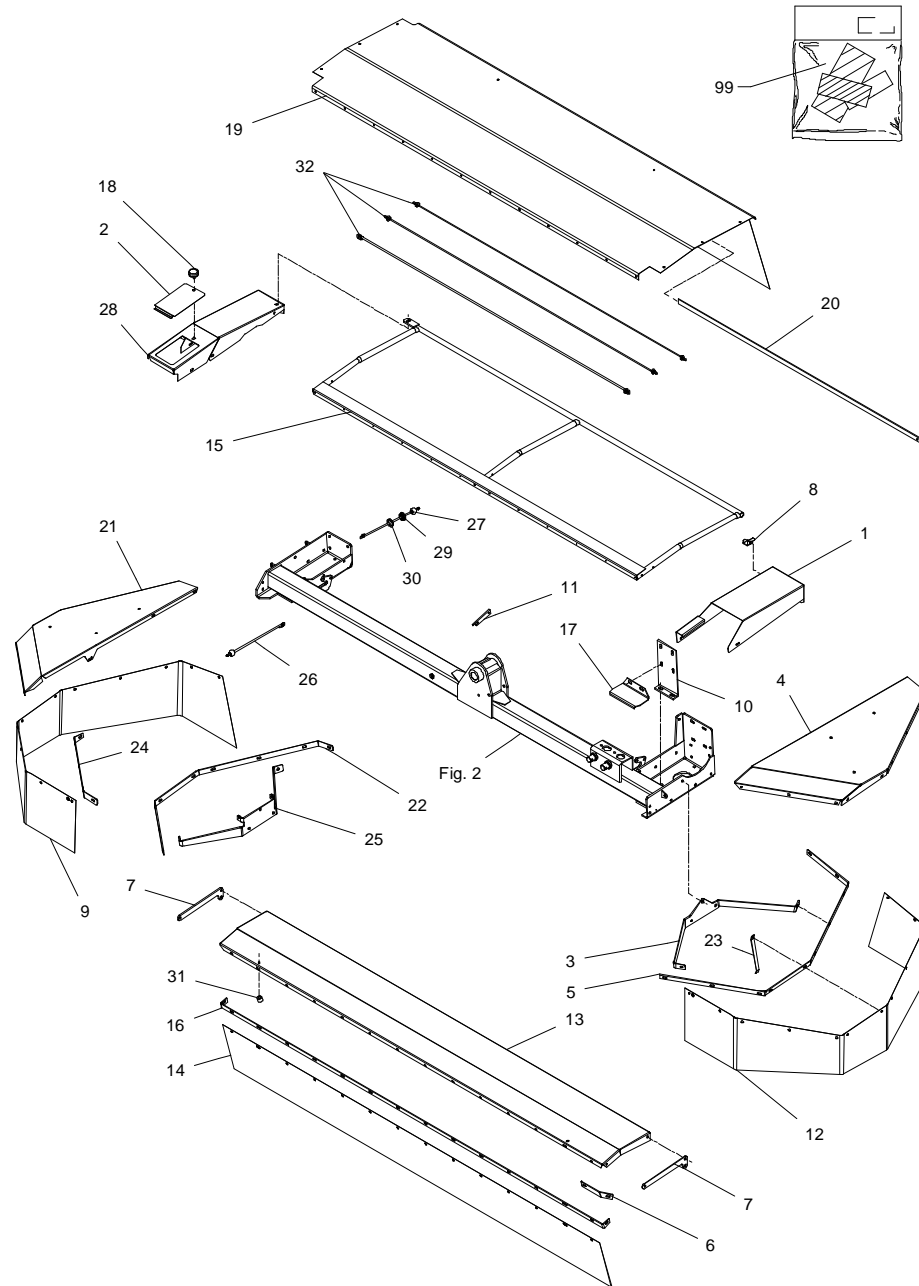

GXS-0002/1 GXS 3205

FIG. 5.

>=2840101401 <=2840101527

HERTIL, DAZU,
TO THIS, A CECI

POS.	VARENUMMER	ANTAL	BENÆVNELSE	BEZEICHNUNG	DESIGNATION		
20.	2228-791X	1	SKINNE SCHIENE		RAIL	1213-2224 1241-1304	1 2
21.	2087-844X	1	SKÆRM, HØJRE SCHUTZ, RECHTE		GUARD, RIGHT	1213-4322 1220-4321 1241-2505	3 3 3
22.	2365-242X	1	SKINNE SCHIENE		RAIL		
23.	2223-576X	1	HOLDER HALTER		HOLDER		
24.	2365-240X	1	SKINNE SCHIENE		RAIL		
25.	2365-142X	1	SKÆRMHOLDER, HØJRE SCHUTZHALTER, RECHTE		GUARD HOLDER, RIGHT		
26.	3365-259X	1	STROP RIEMEN		STRAP		
27.	3365-260X	1	STROP RIEMEN		STRAP		
28.	2365-245X	1	SKÆRM SCHUTZ		GUARD	1220-3922 1241-1304	1 3
29.	2227-637X	1	LEJEBØSNING LAGERBUCHSE		BEARING BUSH	1241-6702	1
30.	1241-6702	1	SPÆNDESKIVE 29-42-5 SCHEIBE 29-42-5		WASHER 29-42-5		
31.	2114-175X	1	BØSNING BUCHSE		BUSH	1214-3122 1220-3321	1 1
32.	3325-291X	3	STROP STROPP		STRAP	1213-2222 1220-2321 1241-1304	2 2 6
99.	3889-280X	1	TRANSFER GXS 3205 AUFKLEBER GXS 3205		TRANSFER GXS 3205		

Fig. 5.1

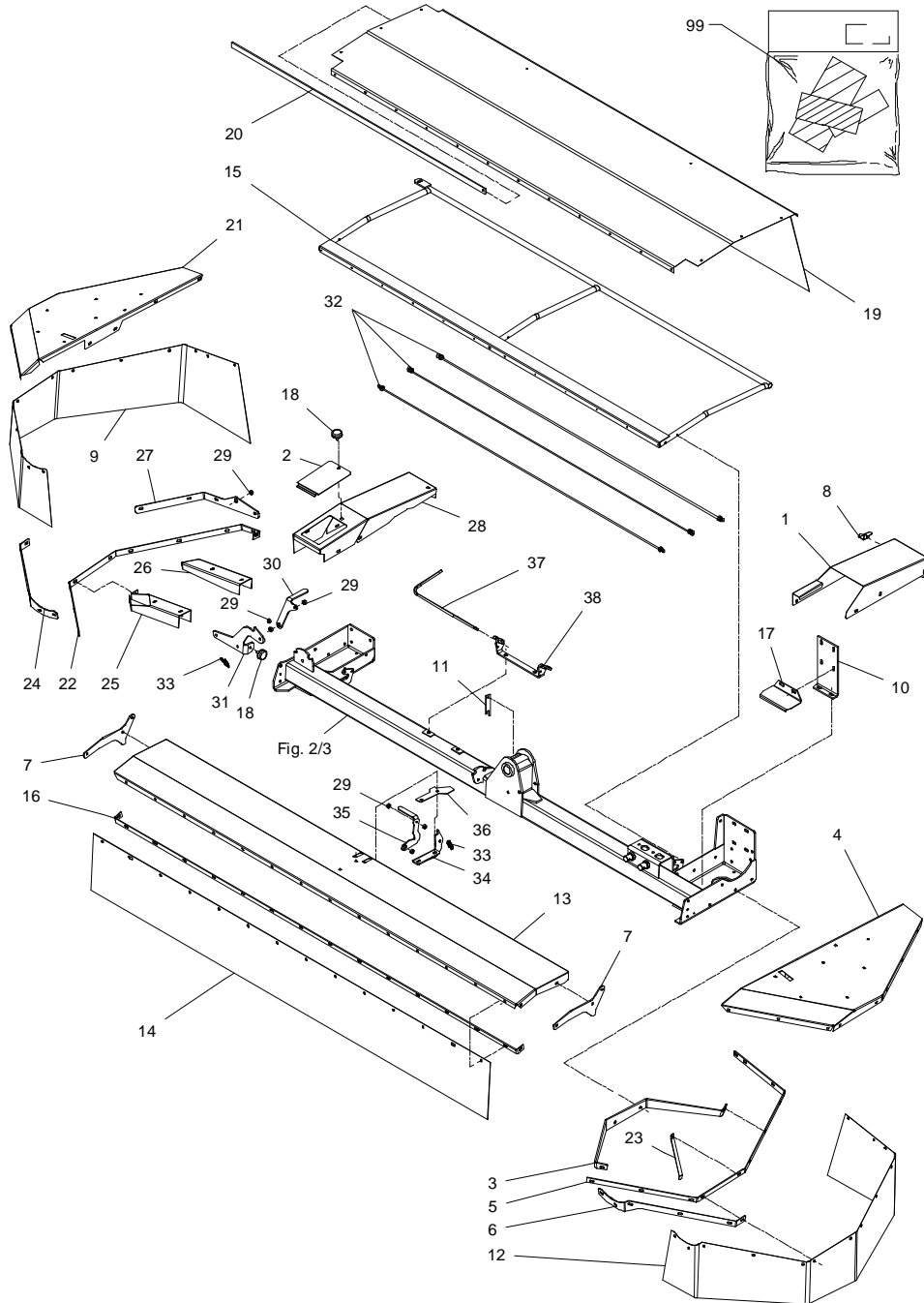

GXS-0002/1 GXS 3205

FIG. 5. 1

>=2840101628

HERTIL, DAZU,
TO THIS, A CECI

POS.	VARENUMMER	ANTAL	BENÆVNELSE	BEZEICHNUNG	DESIGNATION		
1.	2087-850X	1	SKÆRM SCHUTZ		GUARD	1213-3322	1
						1213-4322	2
						1220-3321	1
						1220-4321	2
						1241-2502	2
						1241-3403	4
2.	2325-336X	1	DÆKSEL DECKEL		COVER	1241-2404	1
3.	2087-852A	1	SKÆRMBÆRER SCHIRMTREAGER		GUARD HOLDER		
4.	2087-833A	1	SKÆRM, VENSTRE SCHUTZ, LINKE		GUARD, LEFT	1213-4322	3
						1220-4321	3
						1241-2505	6
5.	2087-851X	1	SKINNE SCHIENE		RAIL		
6.	2322-237X	1	SKINNE F. SIDESKÆRM SCHIENE F. SEITENSCHUTZ		RAIL F. SIDE GUARD		
7.	2322-240X	2	HÆNGSEL SCHARNIER		HINGE	1213-3322	3
						1220-3321	3
						1241-2502	6
8.	2325-603X	1	BESLAG BESCHLAG		CLAMP	1215-2222	1
						1220-2321	1
						1241-2502	1
9.	2322-245X	1	DUG TUCH		CANVAS	1215-3226	3
						1215-3228	7
						1220-3321	10
						1241-2502	8
10.	2325-628X	1	STIVER STÜTZE		SUPPORT	1213-4224	4
						1213-4327	2
						1241-3403	8
11.	2325-335X	1	STOP STOP		STOP	1214-2126	1
						1220-2321	1
						1241-1202	1
12.	2322-246X	1	DUG TUCH		CANVAS	1215-3226	3
						1215-3228	6
						1220-3321	9
						1241-2502	7
13.	2087-843A	1	FORSKÆRM	MAL			
14.	2087-859A	1	DUG, FORRESTE TUCH, VORDERE		CANVAS, FRONT	1215-3226	4
						1215-3228	13
						1220-3321	17
						1241-2502	17
15.	3325-595X	1	BØJLE BUEGEL		HOOP	1213-3322	1
						1213-3622	3
						1213-4622	3
						1220-3122	3
						1220-3321	3
						1220-4321	3
						1241-2404	1
						1393-0105	2
16.	2087-846X	1	SKINNE SCHIENE		RAIL	1213-3322	3
						1220-3321	3
						1241-2502	6
17.	2087-794X	1	SKÆRM ABSCHIRMUNG		GUARD		
18.	1393-0186	2	GUMMIBUFFE GUMMIPUFFER		RUBBER BUFFER		
19.	2320-844A	1	DUG TUCH		CANVAS	1219-0599	12
						1241-1206	12

Fig. 5.1

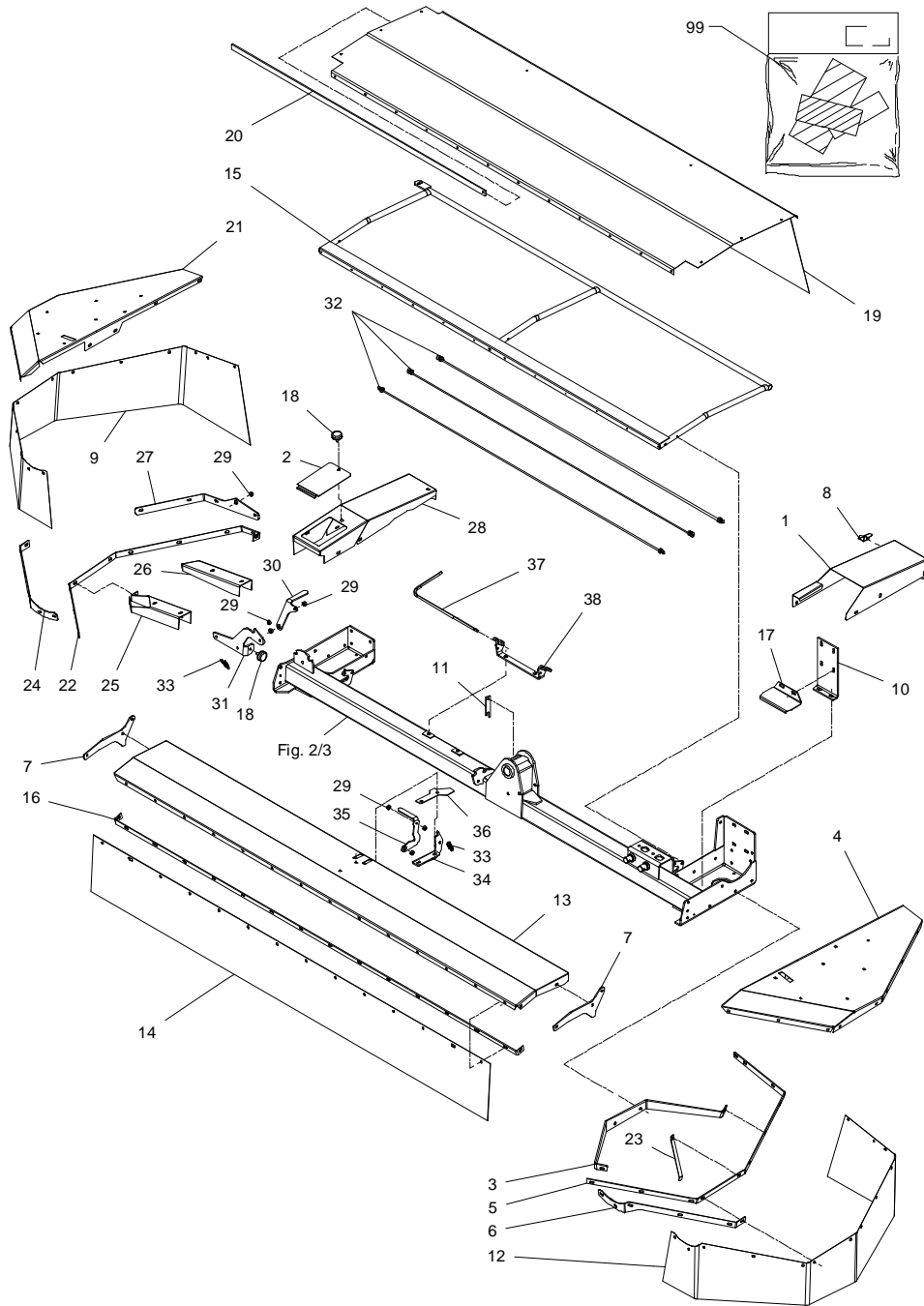

GXS-0002/1 GXS 3205

FIG. 5. 1

>=2840101628

HERTIL, DAZU,
TO THIS, A CECI

POS.	VARENUMMER	ANTAL	BENÆVNELSE	BEZEICHNUNG	DESIGNATION		
20.	2228-791X	1	SKINNE SCHIENE		RAIL	1213-2224	1
						1241-1304	2
21.	2087-844A	1	SKÆRM, HØJRE SCHUTZ, RECHTE		GUARD, RIGHT	1213-4322	3
						1220-4321	3
						1241-2505	3
22.	2365-242A	1	SKINNE SCHIENE		RAIL		
23.	2223-576X	1	HOLDER HALTER		HOLDER		
24.	2322-236X	1	HOLDER HALTER		SUPPORT		
25.	2322-145X	1	KONSOL KONSOLE		BRACKET		
26.	2322-146X	1	KONSOL KONSOLE		BRACKET		
27.	2321-641X	1	HÆNGSEL SCHARNIER		HINGE		
28.	2322-143X	1	SKÆRM SCHUTZ		GUARD	1220-3922	1
						1241-1304	3
29.	2322-243X	7	BØSNING BUCHSE		BUSH	1241-6702	1
30.	2322-238X	1	LÅS SCHLOSS		LOCK		
31.	2322-144X	1	HÆNGSEL SCHARNIER		HINGE	1214-3122	1
						1220-3321	1
32.	3325-291X	3	STROP STROPP		STRAP	1213-2222	2
						1220-2321	2
						1241-1304	6
33.	1432-2297	2	TRÆKFJEDER ZUGFEDER		TENSION SPRING		
34.	2322-234X	1	HÆNGSEL SCHARNIER		HINGE		
35.	2322-235X	1	LÅS SCHLOSS		LOCK		
36.	2322-239X	1	SKÆRM SCHUTZ		GUARD		
37.	2083-706B	1	VÆRKTØJ WERKZEUG		TOOL		
38.	2322-227X	1	HOLDER HALTER		SUPPORT		
99.	3889-280X	1	TRANSFER GXS 3205 AUFKLEBER GXS 3205		TRANSFER GXS 3205		

Fig. 6

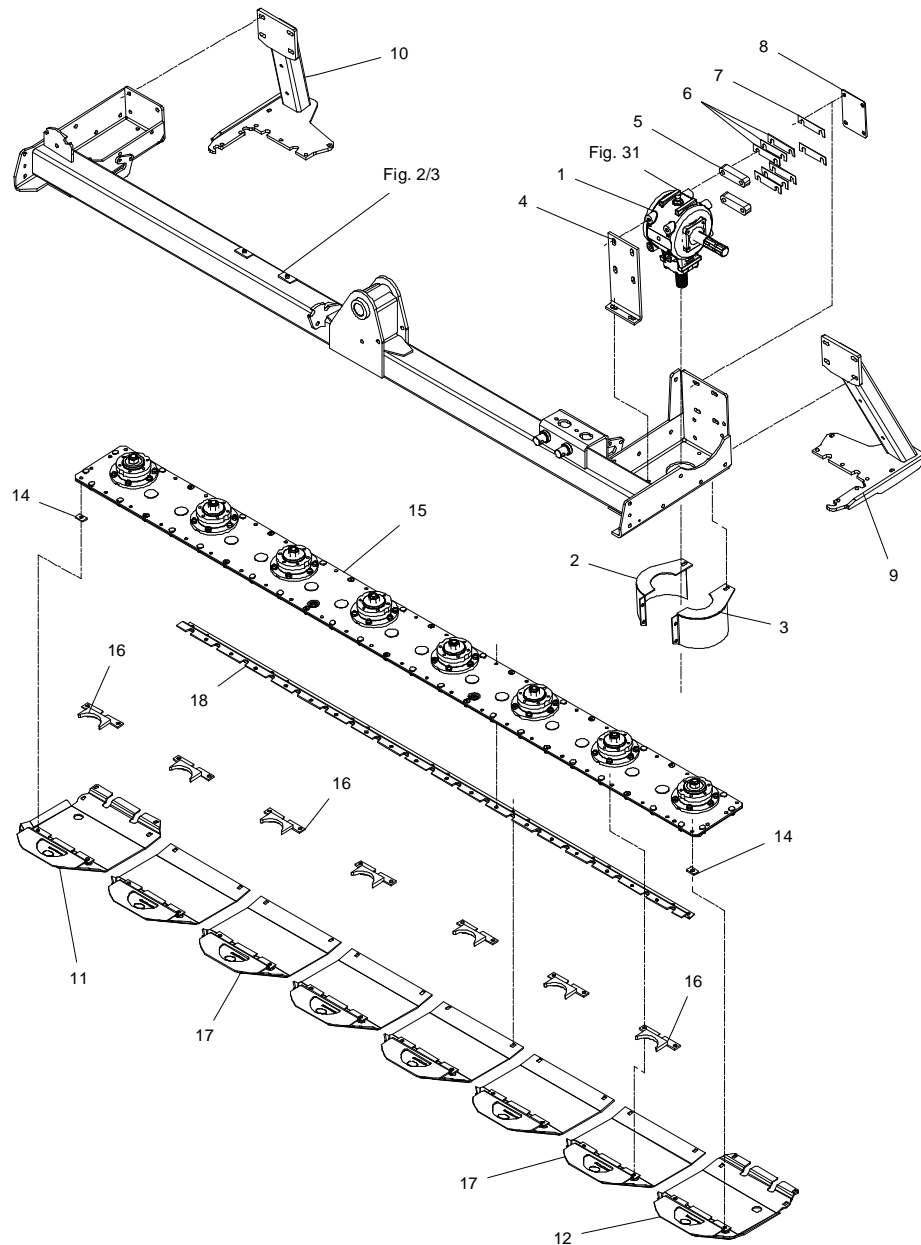

GXS-0002/1 GXS 3205

FIG. 6.

>=2840101401

HERTIL, DAZU,
TO THIS, A CECI

POS.	VARENUMMER	ANTAL	BENÆVNELSE	BEZEICHNUNG	DESIGNATION		
1.	3225-578A	1	VINKELTRÆK WINKELGETRIEBE		BEVEL GEAR		
2.	3325-612X	1	SKÆRM, VENSTRE SCHUTZ, LINKE		GUARD, LEFT		
3.	3325-611X	1	SKÆRM, VENSTRE SCHUTZ, LINKE		GUARD, LEFT	1213-3222	2
						1213-3322	2
						1220-3321	4
						1241-2502	8
4.	2325-628X	1	STIVER STUETZE		SUPPORT	1213-4224	4
						1213-4327	2
						1241-3403	8
5.	2229-501X	2	MELLEMLÆG ZWISCHENAUSLEGER		SHIM		
6.	2225-576X	6	MELLEMLÆG 2 MM ZWISCHENLAGE 2 MM		SHIM 2 MM		
7.	2225-577X	2	MELLEMLÆG 1 MM ZWISCHENLAGE 1 MM		SHIM 1 MM		
8.	2322-136X	1	SPENDEPLADE SPANNPLATTE		RETAINING PLATE	1214-4228	4
						1241-9982	2
9.	3088-571X	1	BEN, VENSTRE BEIN, LINKE		LEG, LEFT		
10.	3088-575X	1	BEN, HØJRE BEIN, RECHTE		LEG, RIGHT		
11.	3088-564X	1	SLÆBESKO, YDRE GLEITKUPE, ÅUSSER		GUIDE SHOE, OUTER	1215-3320	2
						1219-0210	7
						1220-3323	9
						1241-2502	2
12.	3088-563X	1	SLÆBESKO, YDRE - VENSTRE GLEITKUPE, ÅUSSER - LINKE		GUIDE SHOE, OUTER - LEFT	1215-3320	2
						1219-0210	7
						1220-3323	9
						1241-2502	2
14.	2088-566X	2	MELLEMLÆG DICHTUNG		DISTANCE PIECE		
15.	1380-0228	1	KNIVBJÆLKE 8-SKIVER MÄHBALKEN 8-SCHEIBEN		CUTTER BAR 8-DISC		
16.	3088-554X	7	MODSKÆR GEGENSCHNEIDE		SHEAR BAR		
17.	3088-549X	6	SLÆBESKO GLEITKUPE		GUIDE SHOE		
18.	2088-567X	1	FORSTÆRKNING VERSTÄRKERUNG		REINFORCEMENT		

Fig. 7

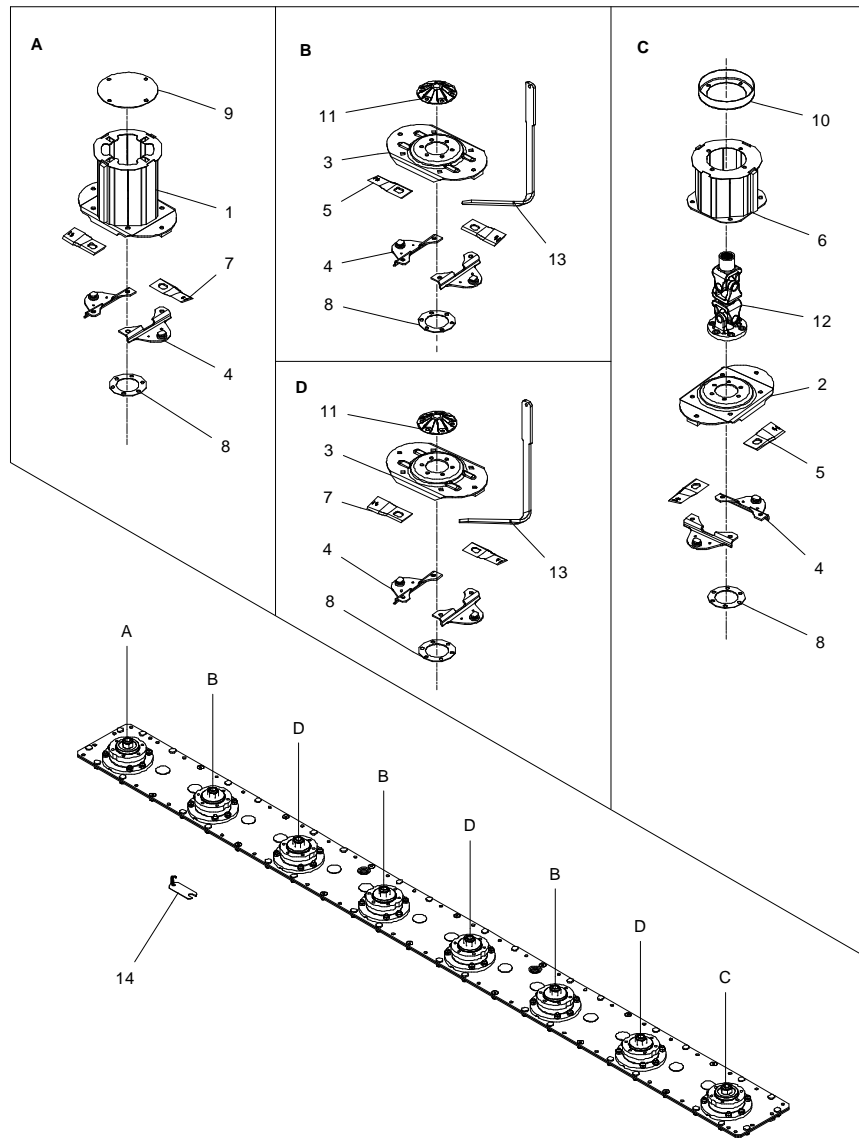

GXS-0002/1 GXS 3205

FIG. 7.

>=2840101401

HERTIL, DAZU,
TO THIS, A CECI

POS.	VARENUMMER	ANTAL	BENÆVNELSE	BEZEICHNUNG	DESIGNATION		
1.	3088-541X	1	SKIVE SCHEIBE		WASHER	1213-3222	4
						1220-3922	4
2.	3088-539X	1	INDGANGSSKIVE ANTRIEBSSCHEIBE		INPUT WASHER		
3.	3088-536X	6	SKIVE SCHEIBE		WASHER	1215-4220	4
						1220-4323	4
						1241-3403	4
4.	3229-517A	16	KNIVHOLDER MESSERHALTER		KNIFE HOLDER	1219-0245	2
						1220-4323	2
						1241-3403	2
5.	1380-0047	8	KNIV H. VREDET 55-4-134 MESSER, RECHTE		KNIFE, RIGHT		
6.	3087-449A	1	TROMLE, INDGANG TROMMEL, EIN		BARREL, IN	1213-3224	4
						1219-0290	4
						1220-3323	4
7.	1380-0046	8	KNIV, VENSTRE MESSER, LINKS		KNIFE, LEFT		
8.	2085-704X	8	MELLEMLÆG DICHTUNG		DISTANCE PIECE		
9.	2089-180X	1	TÆTNING DICHTUNG		TIGHTENING		
10.	2225-397X	2	TÆTNING DICHTUNG		TIGHTENING	1213-3224	8
11.	2085-703X	6	TOP OBERTEIL		TOP	1213-3224	6
						1241-2402	6
12.	1350-0144	1	BJÆLKEDREV L= 312 MM BALKEN L= 312 MM		CUTTERBAR L= 312 MM	1219-0266	6
13.	2083-706B	1	VERKTØJ WERKZEUG		TOOL		
14.	3210-436X	1	KONTROLLERE KONTROLLEHRE		CONTROL GAUGE		

Fig. 8

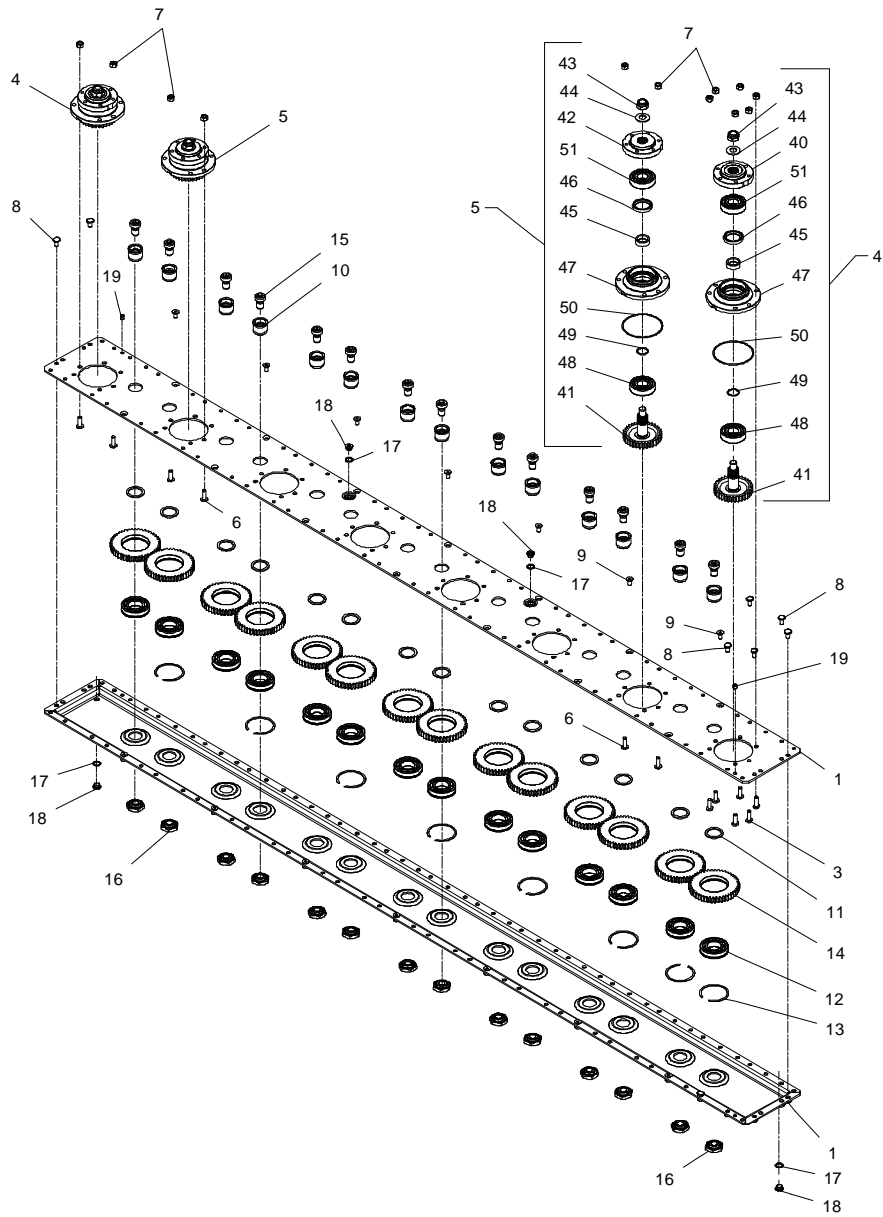

GXS-0002/1 GXS 3205

FIG. 8.

>=2840101401

HERTIL, DAZU,
TO THIS, A CECI

POS.	VARENUMMER	ANTAL	BENÆVNELSE	BEZEICHNUNG	DESIGNATION
.	1380-0228		KNIVBJÆLKE 8-SKIVER MÅHBALKEN 8-SCHEIBEN		CUTTER BAR 8-DISC
1.	3085-747X	1	KNIVBJÆLKE HALVDEL 8-SK SCHNITTBALKEN		CUTTERBAR
3.	1219-0210	34	SKRUE M10-30 SCHRAUBE M10-30	12.9 DELTA B 12.9 DELTA B	SCREW M10-30 12.9 DELTA B
4.	3085-738X	2	LEJEHUS DREV RITZEL LAGERGEHÅUSE		PINION BEARINGHOUSING
5.	3085-705X	6	LEJEHUS LAGERGEHÅUSE		BEARING HOUSING
6.	2085-733X	14	KNIVBJÆLKE SKRUE SCHNITTBALKEN SCHRAUBE		SCREW FOR CUTTERBAR
7.	2085-729X	98	MØTRIK M10 H=10 MUTTER M10 H=10		NUT M10 H=10
8.	1219-0208	36	KNIVBJÆLKE SKRUE SCHNITTBALKEN SCHRAUBE		SCREW FOR CUTTERBAR
9.	1219-0227	14	UNBRACOSKRUE M10-20 MK INNENSECHSKANTSCHR M10-20 MK		ALLEN SCREW M10-20 MK
10.	2085-717X	14	TAP ZAPPEN		DOWEL
11.	2085-719X	14	SKIVE 40, 3X51, 3X3 SCHEIBE 40, 3X51, 3X3		WASHER 40, 3X51, 3X3
12.	2085-720X	14	LEJE 6208 N/C3 LAGER 6208 N/C3		BEARING 6208 N/C3
13.	2085-721X	8	SPRINGRING KLEMMRING		SPRINGRING
14.	2085-724X	14	MELLEMHJUL Z45 M3 ZWISCHENRAD Z45 M3		INTERMEDIATE WHEEL Z45 M3
15.	2085-718X	14	SKRUE M20X18 SCHRAUBE M20X18		SCREW M20X18
16.	2085-723X	14	MØTRIK MUTTER		NUT
17.	1315-9671	4	SKIVE 17 X 22 X 1,5 SCHEIBE 17 X 22 X 1,5		WASHER 17 X 22 X 1,5
18.	2085-731X	4	PROP 3/8" VERSCHLUSS 3/8"		PLUG 3/8"
19.	2085-735X	2	SPÆNDSTIFT M10X12 D1481 SPANNSTIFT M10X12 D1481		ROLL PIN M10X12 D1481
40.	2085-739X	1	FLANGE FLANSCH		FLANGE
41.	2085-706X	1	TANDHJUL Z34 M3 ZAHNRAD Z34 M3		SPROCKET WHEEL Z34 M3
42.	2085-707X	1	FLANGE FLANSCH		FLANGE
43.	2085-709X	1	LÅSEMØTRIK M20X1,5 H=17,3 GEGENMUTTER M20X1,5 H=17,3		LOCK NUT M20X1,5 H=17,3
44.	1434-0108	1	TALLERKENFJEDER 20,0-40-2,5 TELLERFEDER 20,0-40-2,5		DISC SPRING 20,0-40-2,5
45.	2085-710X	1	BØSNING BUCHSE		BUSH
46.	2085-711X	1	OLIETÆTNINGSRING DICHTUNGSRING ÖL		SEAL RING OIL
47.	2085-708X	1	LEJEHUS LAGERGEHÅUSE		BEARING HOUSING

Fig. 8

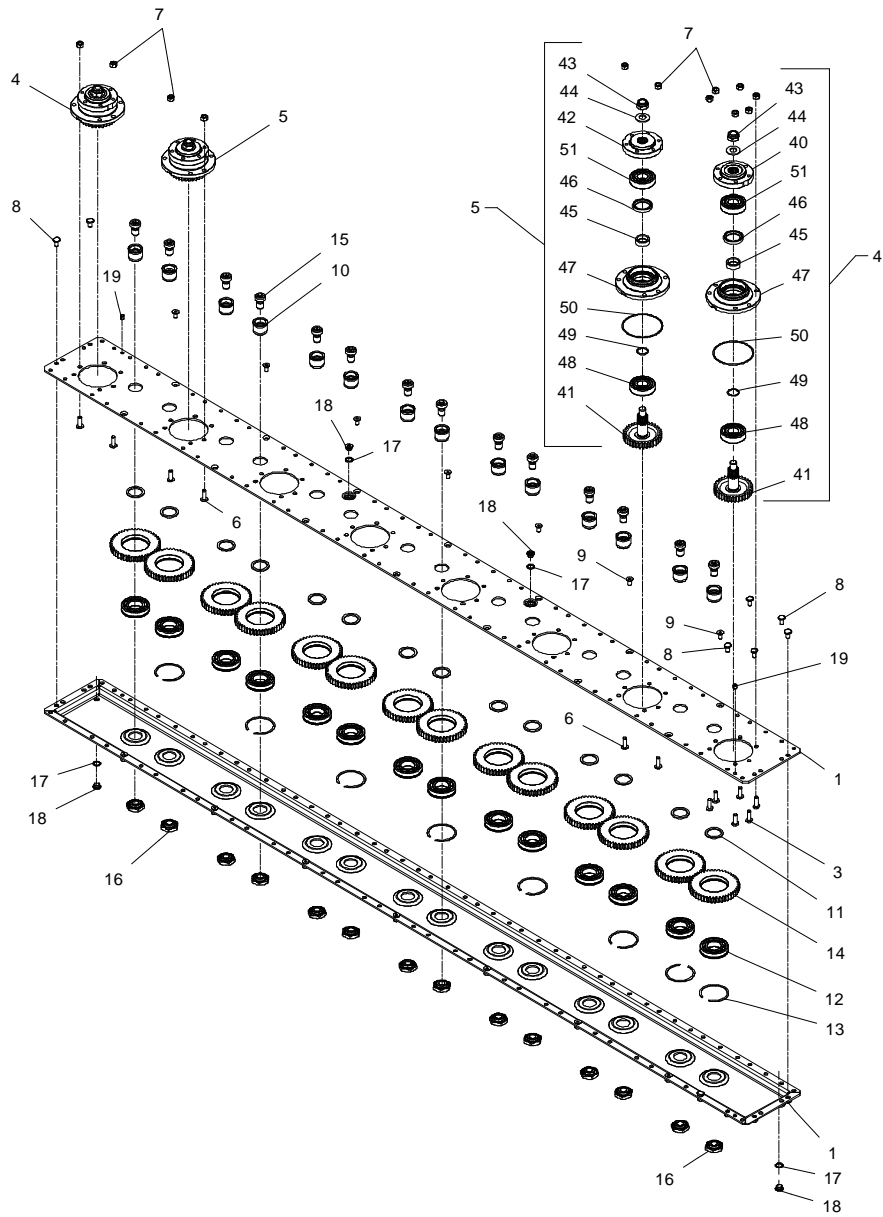

GXS-0002/1 GXS 3205

FIG. 8.

>=2840101401

HERTIL, DAZU,
TO THIS, A CECI

POS.	VARENUMMER	ANTAL	BENÆVNELSE	BEZEICHNUNG	DESIGNATION
48.	2085-712X	1	LEJE 6306C3/Z2 LAGER 6306C3/Z2		BEARING 6306C3/Z2
49.	2085-714X	1	O-RING 3112 O-RING 3112		O-RING 3112
50.	2085-715X	1	O-RING O-RING		O-RING
51.	2085-716X	1	KUGLELEJE 6306 C3 2RS KUGELLAGER 6306 C3 2RS		BALL BEARING 6306 C3 2RS

Fig. 9

GXS-0002/1 GXS 3205

FIG. 9.

>=2840101401

HERTIL, DAZU,
TO THIS, A CECI

POS.	VARENUMMER	ANTAL	BENÆVNELSE	BEZEICHNUNG	DESIGNATION		
1.	2279-221X	2	DEKSEL DECKEL		COVER		
2.	2279-223X	2	AFSTANDSRING DISTANZRING		DISTANCE RING		
3.	1331-2303	4	KUGLELEJE 6005 2RS KUGELLAGER 6005 2RS		BALL BEARING 6005 2RS		
4.	2279-023X	2	SKIVE SCHEIBE		WASHER		
5.	1219-0220	2	UNBRACOSKRUE M12-25 MC INNENSECHSKANTISCHR. M12-25 MC		ALLEN SCREW M12-25 MC		
6.	1165-0189	2	AFDEKNINGSPROP ABDECKUNGSVERSCHLUSS		COVERING PLUG		
7.	1255-4102	4	LÅSERING 47 MM INDVENDIG SICHERINGSRING 47 MM INNEN		SNAP RING 47 MM INNER		
8.	3279-502X	2	TALLERKEN SCHEIBE		REINFORCED DISC		
9.	3088-078X	T	1 ARM F. SKÅRRULLE ARN F. SCHWADROLLE		ARM F. SWATH ROLLER		
10.	4220-1295	T	1 SKÅRRULLE, VENSTRE SCHWADROLLE, LINKE		SWATH ROLLER, LEFT	1214-3422	1
						1220-3321	1
						1241-2502	1
19.	3088-050X	1	1 ARM F. SKÅRRULLE ARM F. SCHWADROLLE		ARM F. SWATH ROLLER		
20.	3088-076X	1	1 SKÅRRULLE, SML. SCHWADROLLE SATZ		SWATH ROLLER SET	1214-3422	1
						1220-3321	1
						1241-2502	1

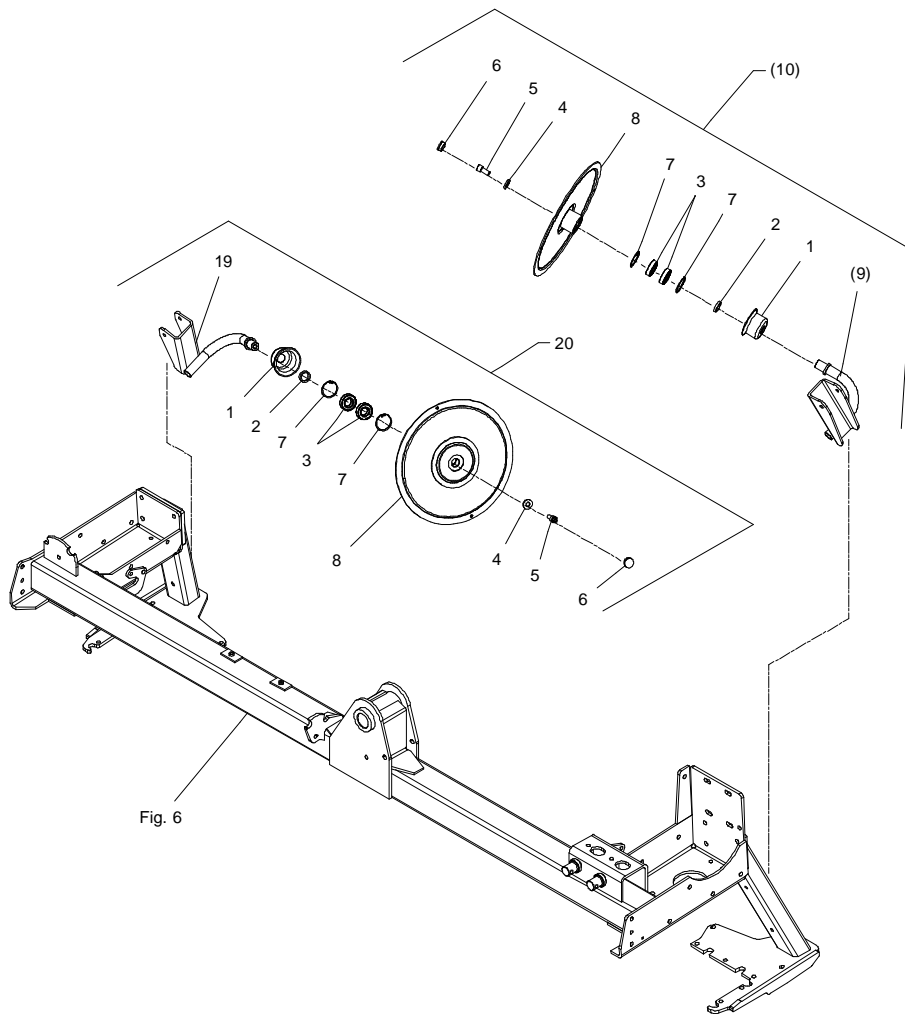
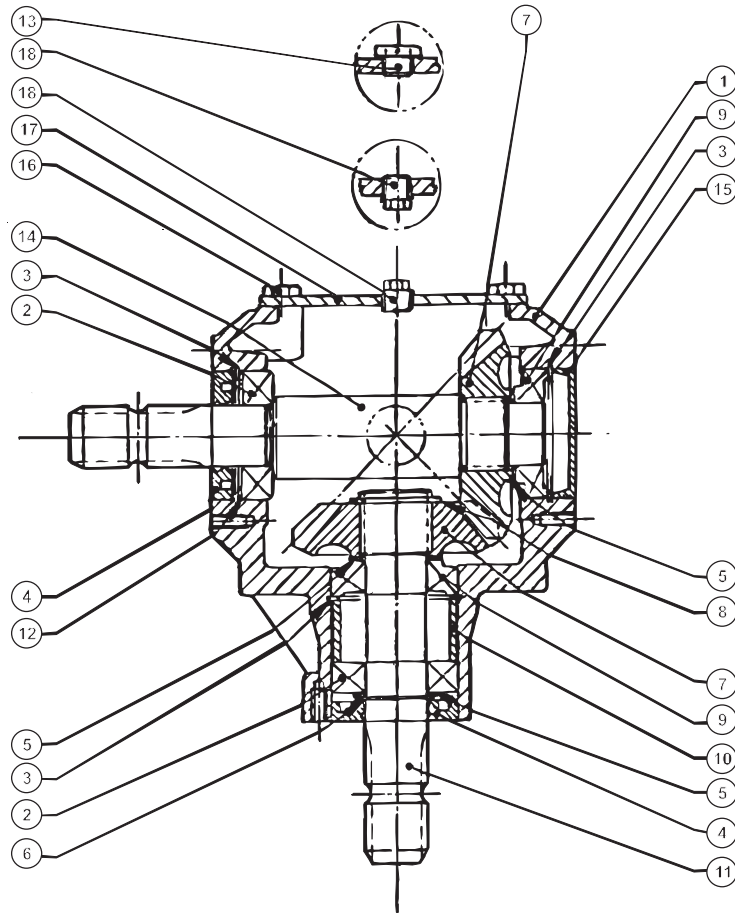

Fig. 6

Fig. 30



GXS-0002/1 GXS 3205

FIG. 30.

>=2840101401

HERTIL, DAZU,
TO THIS, A CECI

POS.	VARENUMMER	ANTAL	BENÆVNELSE BEZEICHNUNG	DESIGNATION
.	3010-608X		VINKELTRÆK 1000 O/M WINKELGETRIEBE 1000 U/M	BEVEL GEAR 1000 RPM
1.	1315-9154	1	HUS GEHÆUSE	HOUSING
2.	1331-3104	2	KUGLELEJE 6207 KUGELLAGER 6207	BALL BEARING 6207
3.	1255-6101	3	LÅSERING 72 MM INDVENDIG SICHERINGSRING 72 MM INNEN	SNAP RING 72 MM INNER
4.	1332-3601	2	OLIETÆTNINGSRING 35-72-12 DICHTUNGSRING 35-72-12	OIL SEAL 35-72-12
5.	1315-9140	3	SKIVESÆT DISTANZSCHEIBENSATZ	SET OF SHIMS
6.	1255-3202	1	LÅSERING 35 MM UDVENDIG SICHERINGSRING 35 MM AUSSEN	SNAP RING 35 MM OUTER
7.	1315-9234	2	TANDHJUL Z=18 ZAHNRAD Z=18	SPROCKET WHEEL Z=18
8.	1255-4201	1	LÅSERING 40 MM UDVENDIG SICHERINGSRING 40 MM AUSSEN	SNAP RING 40 MM OUTER
9.	1331-9909	2	RULLELEJE ROLLENLAGER	ROLLER BEARING
10.	1315-9161	1	AFSTANDSSKIVE DISTANZSCHEIBE	DISTANCE WASHER
11.	1315-9179	1	AKSEL WELLE	SHAFT
12.	1315-9142	1	TÆTNINGSRING DICHTUNGSRING	TIGHTENING RING
13.	1315-9235	1	PROP ROHRVERSCHLUSS	PLUG
14.	1315-9236	1	AKSEL WELLE	SHAFT
15.	1315-9237	1	DEKSEL DECKEL	COVER
16.	1213-3222	4	STÅLSÆTSKRUE M10-20 ST. SETSCHRAUBE M10-20	STEEL SET SCREW M10-20
17.	1315-9162	1	DEKSEL DECKEL	COVER
18.	1311-2202	2	RØRPROP ROHRVERSCHLUSS	PLUG

Fig. 31

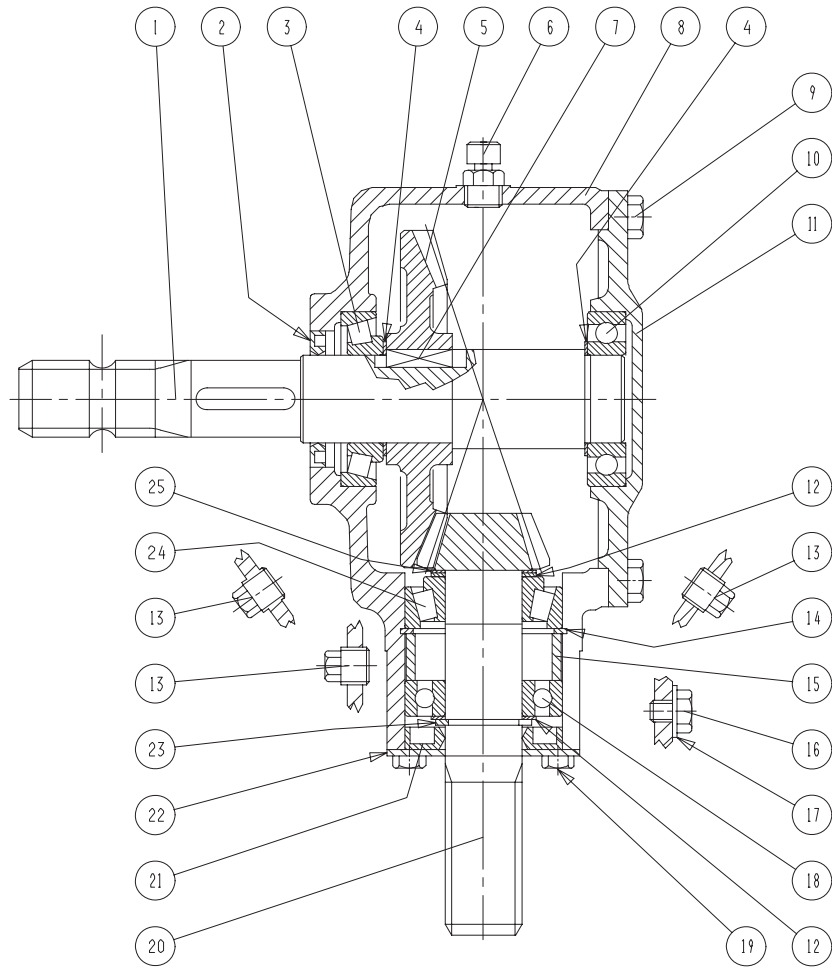

GXS-0002/1 GXS 3205

FIG. 31.

>=2840101401

HERTIL, DAZU,
TO THIS, A CECI

POS.	VARENUMMER	ANTAL	BENÆVNELSE	BEZEICHNUNG	DESIGNATION
.	3225-578A		VINKELTRÆK WINKELGETRIEBE		BEVEL GEAR
1.	1315-9164	1	AKSEL WELLE		SHAFT
2.	1332-4502	1	OLIETÆTNINGSRING M40-62-7 DICHTUNGSRING M40-62-7		OIL SEAL M40-62-7
3.	1331-9994	1	RULLELEJE KONISK 30208A ROLLENLAGER 30208A		ROLLER BEARING 30208A
4.	1315-9109	2	AFSTANDSRING, SÆT DISTANZRING, SATZ		DISTANCE RING, SET
5.	1315-9163	1	KRONHJUL KRONRAD		CROWN WHEEL
6.	1315-9167	1	UDLØFTNINGSPROP ENTLÜFTUNGSSCHRAUBE		AIR ESCAPE PLUG
7.	1338-0102	1	PASFEDER 12-8-28 FEDERKEIL 12-8-28		FLAT KEY 12-8-28
8.	1315-9317	1	HUS GEHÄUSE		HOUSING
9.	1213-3224	8	STÅLSÆTSKRUE M10-25 ST. SÆTSCHRAUBE M10-25		STEEL SET SCREW M10-25
10.	1331-3106	1	KUGLELEJE 6208 KUGELLAGER 6208		BALL BEARING 6208
11.	1315-9318	1	DÆKSEL DECKEL		COVER
12.	1315-9140	2	SKIVESÆT DISTANZSCHEIBENSATZ		SET OF SHIMS
13.	1311-2201	3	PROP VERSCHLUSS		PLUG
14.	1255-6101	1	LÅSERING 72 MM INDVENDIG SICHERINGSRING 72 MM INNEN		SNAP RING 72 MM INNER
15.	1315-9301	1	AFSTANDSBØSNING DISTANZBUCHSE		DISTANCE BUSH
16.	1315-9136	1	BOLT M10-10 BOLZEN M10-10		BOLT M10-10
17.	1315-9282	1	KOBBERSKIVE 10,5-18 KUPFERSCHEIBE 10,5-18		COPPER WASHER 10,5-18
18.	1331-3104	1	KUGLELEJE 6207 KUGELLAGER 6207		BALL BEARING 6207
19.	1213-2126	4	STÅLSÆTSKRUE M8-15 ST. SÆTSCHRAUBE M8-15		STEEL SET SCREW M8-15
20.	1315-9319	1	SPIDSHJUL Z=12 ZAHNRAD Z=12		BEVEL PINION WHEEL Z=12
21.	1332-3602	1	OLIETÆTNINGSRING 35-72-10 DICHTUNGSRING 35-72-10		OIL SEAL 35-72-10
22.	1315-9165	1	DÆKSEL DECKEL		COVER
23.	1315-9191	1	LÅSERING 35 SICHERUNGSRING 35		SNAP RING 35
24.	1331-9910	1	RULLELEJE ROLLENLAGER		ROLLER BEARING
25.	1315-9220	1	PASSKIVE 35.3-1.3 SCHEIBE 35.3-1.3		WASHER 35.3-1.3

Fig. 32

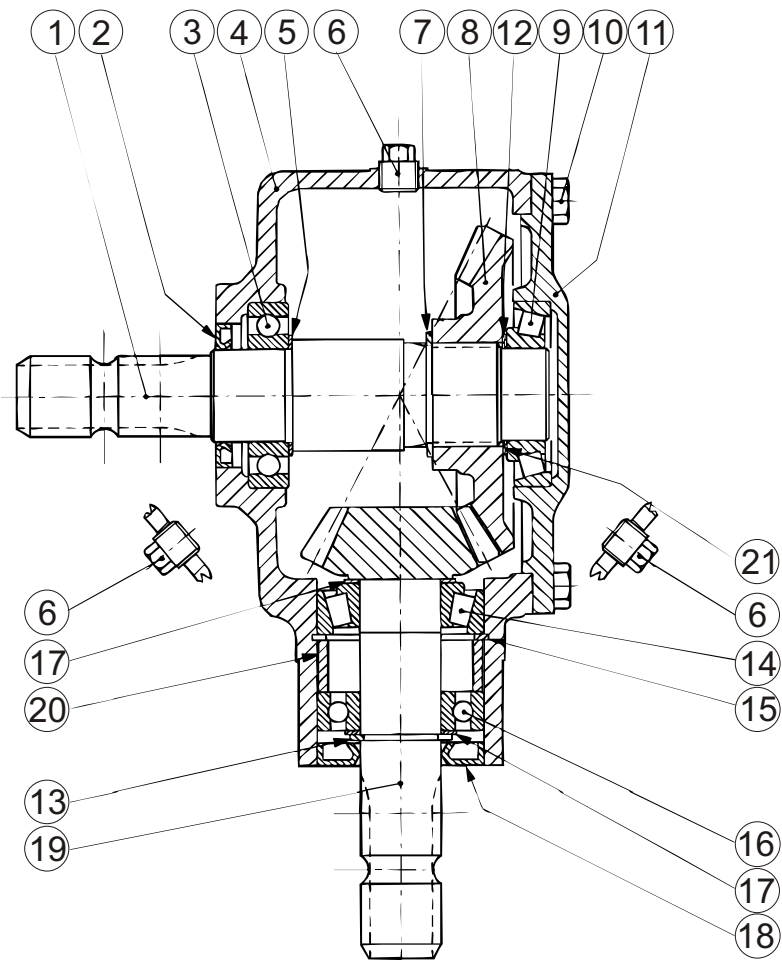

GXS-0002/1 GXS 3205

FIG. 32.

>=2840101401

HERTIL, DAZU,
TO THIS, A CECI

POS.	VARENUMMER	ANTAL	BENÆVNELSE BEZEICHNUNG	DESIGNATION
.	3010-605C		VINKELTRÆK 540 RPM WINKELGETRIEBE 540 RPM	BEVEL GEAR 540 RPM
1.	1315-9426	1	AKSEL WELLE	SHAFT
2.	1332-4502	1	OLIETÆTNINGSRING M40-62-7 DICHTUNGSRING M40-62-7	OIL SEAL M40-62-7
3.	1331-3106	1	KUGLELEJE 6208 KUGELLAGER 6208	BALL BEARING 6208
4.	1315-9297	1	HUS GEHÆUSE	HOUSING
5.	1315-9109	2	AFSTANDSRING, SÆT DISTANZRING, SATZ	DISTANCE RING, SET
6.	1311-2201	3	PROP VERSCHLUSS	PLUG
7.	1315-9416	1	LÅSERING 45 SICHERUNGSRING 45	SNAP RING 45
8.	1315-9427	1	KRONE KRONE	CROWN
9.	1331-9994	1	RULLELEJE KONISK 30208A ROLLENLAGER 30208A	ROLLER BEARING 30208A
10.	1213-3224	8	STÅLSÆTSKRUE M10-25 ST. SÆTSCHRAUBE M10-25	STEEL SET SCREW M10-25
11.	1315-9318	1	DEKSEL DECKEL	COVER
12.	1315-9428	1	SKIVE SCHEIBE	SHIM
13.	1315-9429	1	LÅSERING SICHERUNGSRING	SNAP RING
14.	1315-9430	1	LEJE LAGER	BEARING
15.	1255-6101	1	LÅSERING 72 MM INDVENDIG SICHERUNGSRING 72 MM INNEN	SNAP RING 72 MM INNER
16.	1315-9431	1	LEJE LAGER	BEARING
17.	1315-9140	1	SKIVESÆT DISTANZSCHEIBENSATZ	SET OF SHIMS
18.	1332-3601	1	OLIETÆTNINGSRING 35-72-12 DICHTUNGSRING 35-72-12	OIL SEAL 35-72-12
19.	1315-9300	1	SPIDSHJUL KEGELRAD	BEVEL PINON WHEEL
20.	1315-9301	1	AFSTANDSBØSNING DISTANZBUCHSE	DISTANCE BUSH
21.	1315-9432	1	SKIVE SCHEIBE	SHIM

Fig. 40

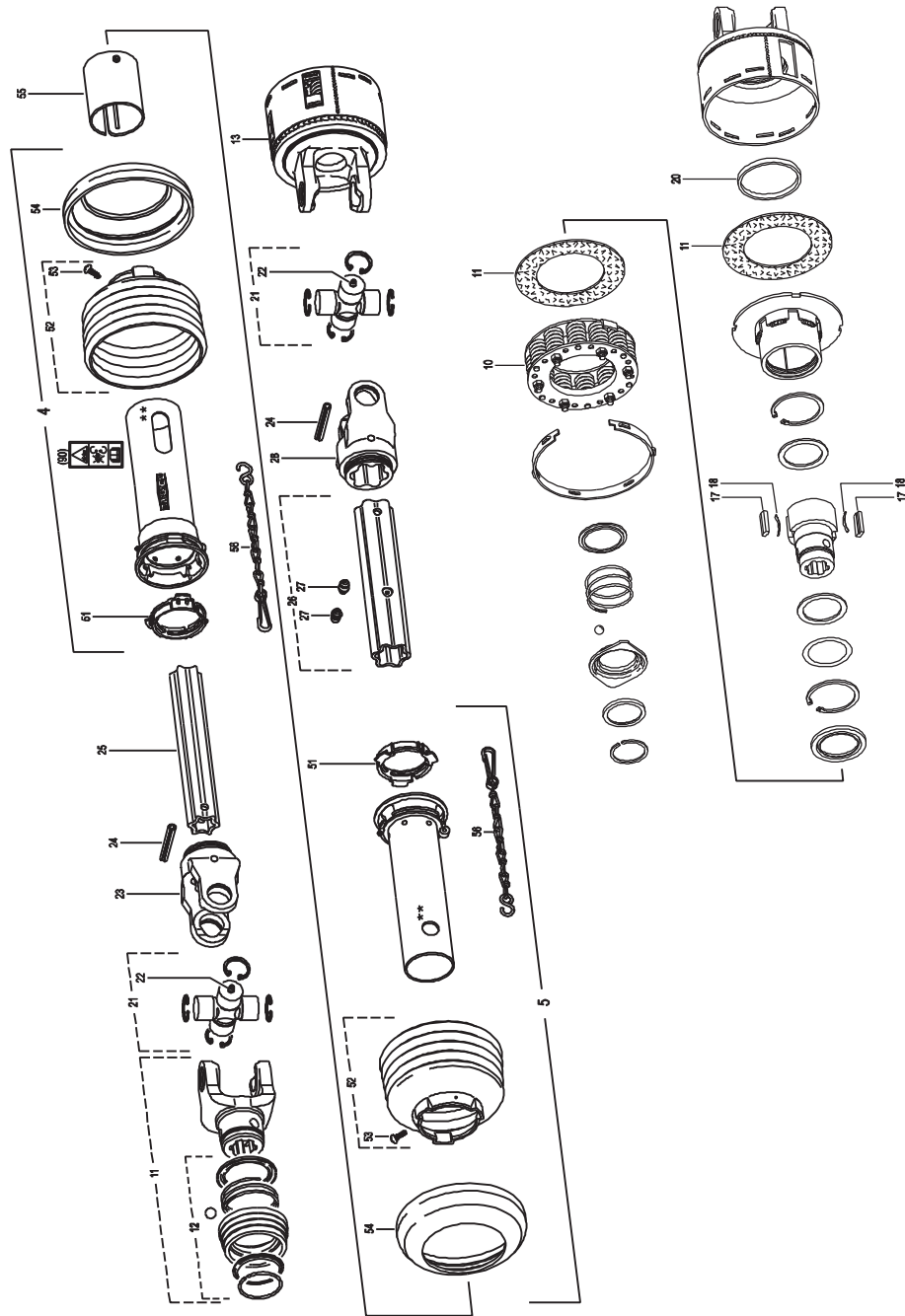

GXS-0002/1 GXS 3205

FIG. 40.

>=2840101401

HERTIL, DAZU,
TO THIS, A CECI

POS.	VARENUMMER	ANTAL	BENEVNELSE	BEZEICHNUNG	DESIGNATION
.	1340-5117		KRAFTOVERFØRINGSAKSEL GELENKWELLE		PTO SHAFT
4.	1342-3088	1	BESKYTTELSERØR, UDV. SCHUTZROHR, AUSSEN		PROTECTION TUBE, OUTER
5.	1342-3089	1	RØR, INDV. SCHUTZ, INNERE		GUARD, INNER
10.	1341-9558	1	FJEDER KPL. FEDER KPL.		SPRING CPL.
11.	1341-9569	2	FRIKTIONSBELEGNING REIBSCHEIBE		FRICTION DISK
17.	1340-9600	2	KILE KEIL		WEDGE
18.	1340-9596	2	BLADFJEDER BLATTFEDER		LEAF SPRING
20.	1341-9644	1	LØBERING LAUFRING		SUPPORTING ROLLER
21.	1340-9212	2	KRYD KREUTZGARNITURE		CENTRE CROSS
25.	1501-0113	1	PROFILRØR S4LH 1000 MM PROFILROHR GR.S4LH 1000 MM		PROFILE TUBE SIZE S4LH 1000 MM
26.	1501-0117	1	PROFILRØR, 1000 MM PROFILROHR, 1000 MM		PROFIL TUBE, 1000 MM

Fig. 41

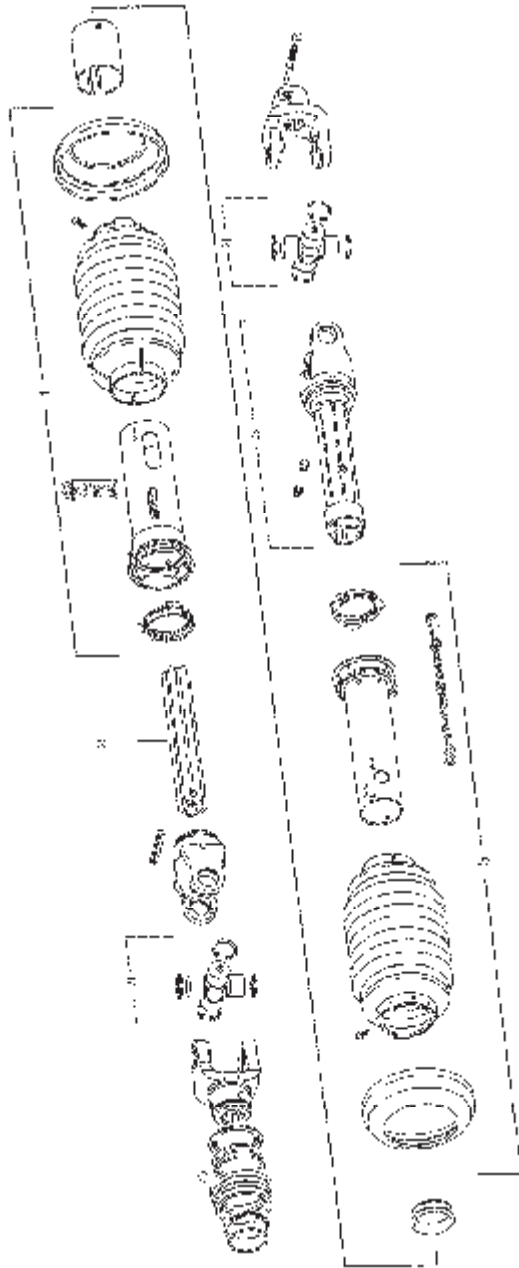

GXS-0002/1 GXS 3205

FIG. 41.

>=2840101401

HERTIL, DAZU,
TO THIS, A CECI

POS.	VARENUMMER	ANTAL	BENØVNELSE	BEZEICHNUNG	DESIGNATION
.	1340-5116		KRAFTOVERFØRINGSAKSEL GELENKWELLE		PTO SHAFT
4.	1342-3092	1	BESKYTTELSERØR UDV. 1000 MM SCHUTZROHR AUSSEN, 1000 MM		PROTECTION TUBE, OUTER 1000 MM
5.	1342-3093	1	BESKYTTELSERØR, INDV. 1000 MM SCHUTZROHR INNEN, 1000 MM		PROTECTION TUBE INNER, 1000 MM
21.	1340-9247	2	KRYDS, KOMPLET KREUZGARNITUR KOMPLETT		CROSS AND BEARING KIT COMPLETE
25.	1501-0113	1	PROFILRØR S4LH 1000 MM PROFILROHR GR.S4LH 1000 MM		PROFILE TUBE SIZE S4LH 1000 MM
26.	1340-9260	1	PROFILRØR MED GAFFEL PROFILROHR MIT GABEL		PROFILE TUBE WITH FORK

Fig. 80

TILBEHØR - ZUBEHÖR - ACCESSORIES

GXS-0002/1 GXS 3205

FIG. 80.
TILBEHØR, ZUBEHÖR, ACCESSORIES

>=2840101401

HERTIL, DAZU,
TO THIS, A CECI

POS.	VARENUMMER	ANTAL	BENEVNELSE	BEZEICHNUNG	DESIGNATION	HERTIL, DAZU, TO THIS, A CECI
1.	1317-0302	2	STIK F/LYNKOBLING ANSCHLUSS F/SCHNELLKUPPLUNG		CONNECTION F/QUICK-COUPLING	
2.	1317-1016	2	STIK-HOLDER STECKERHALTER		PLUG HOLDER	
3.	1311-8537	2	RØRHOLDER ROHRHALTERUNG		SUPPORT FOR TUBE	
4.	1311-8406	1	T-STYKKE T-STUECK		T-PIECE	
5.	1311-8525	1	VINKELFORSKRUNING - L10 WINKELVERSCHRAUBUNG - L10		ANGLE COUPLING - L10	
6.	1311-1411	2	RØRFORSKRUNING ROHRVERSCHRABUNG		PIPE COUPLING	
7.	1317-0442	2	HYDRAULIKSLANGE L=2000 HYDRAULIKSCHLAUCH L=2000		HYDRAULIC HOSE L=2000	
8.	1311-2601	2	NIPPELMUFFE NIPPEL		BUSHING	
9.	1317-3008	1	CYLINDER ZYLINDER		CYLINDER	
10.	1317-0896	1	SLANGE 1/4" L=740 SCHLAUCH 1/4" L=740		HOSE 1/4" L=740	
11.	2307-111X	1	DYSE DUESE		NOZZLE	
12.	1317-9833	1	PAKINGSSET DICHTUNGSSATZ		SET OF GASKETS	
13.	1241-7802	1	SPENDESKIVE 37-52-6 SCHEIBE 37-52-6		WASHER 37-52-6	
14.	4321-1010	1	HYDRAULISK OMSTILLING HYDRAULISCHER UMSTELLUNG		HYDRAULIC TRANSITION	

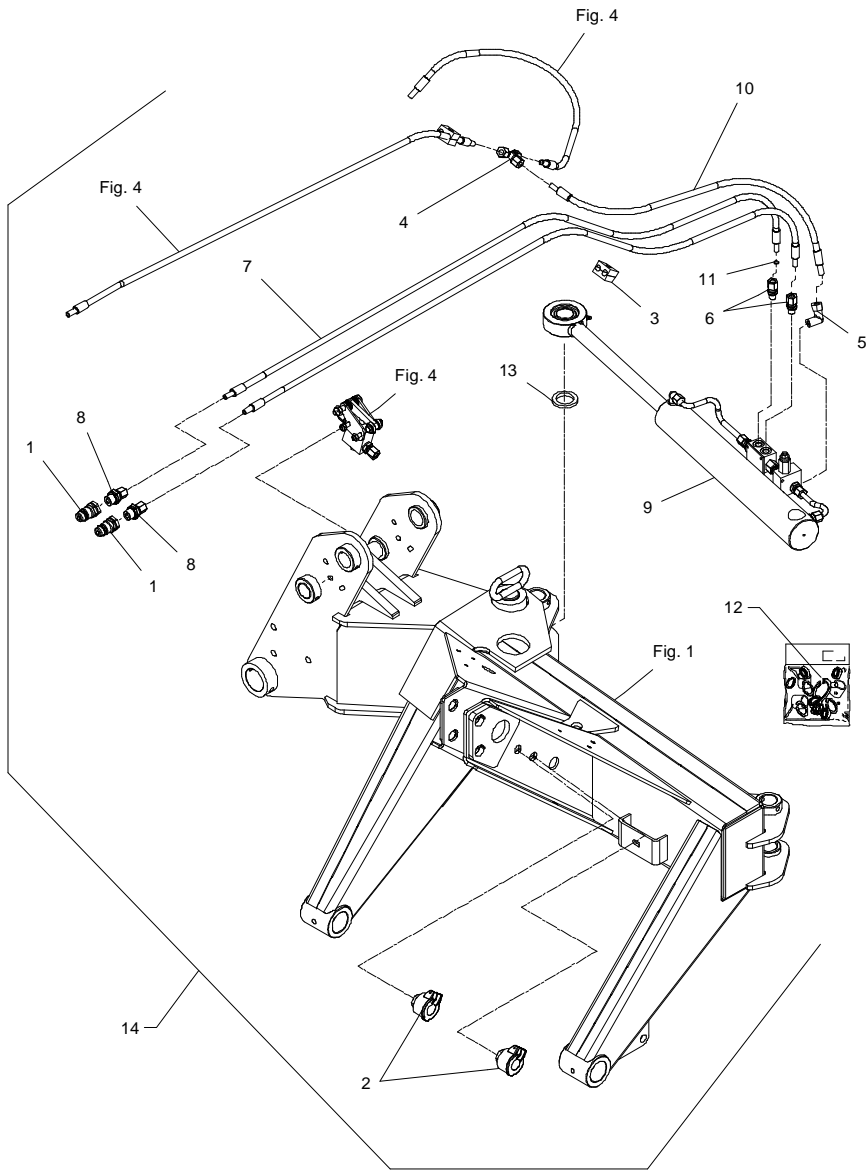

Fig. 81

TILBEHØR - ZUBEHÖR - ACCESSORIES

GXS-0002/1 GXS 3205

FIG. 81.
TILBEHØR, ZUBEHÖR, ACCESSORIES

>=2840101401

HERTIL, DAZU,
TO THIS, A CECI

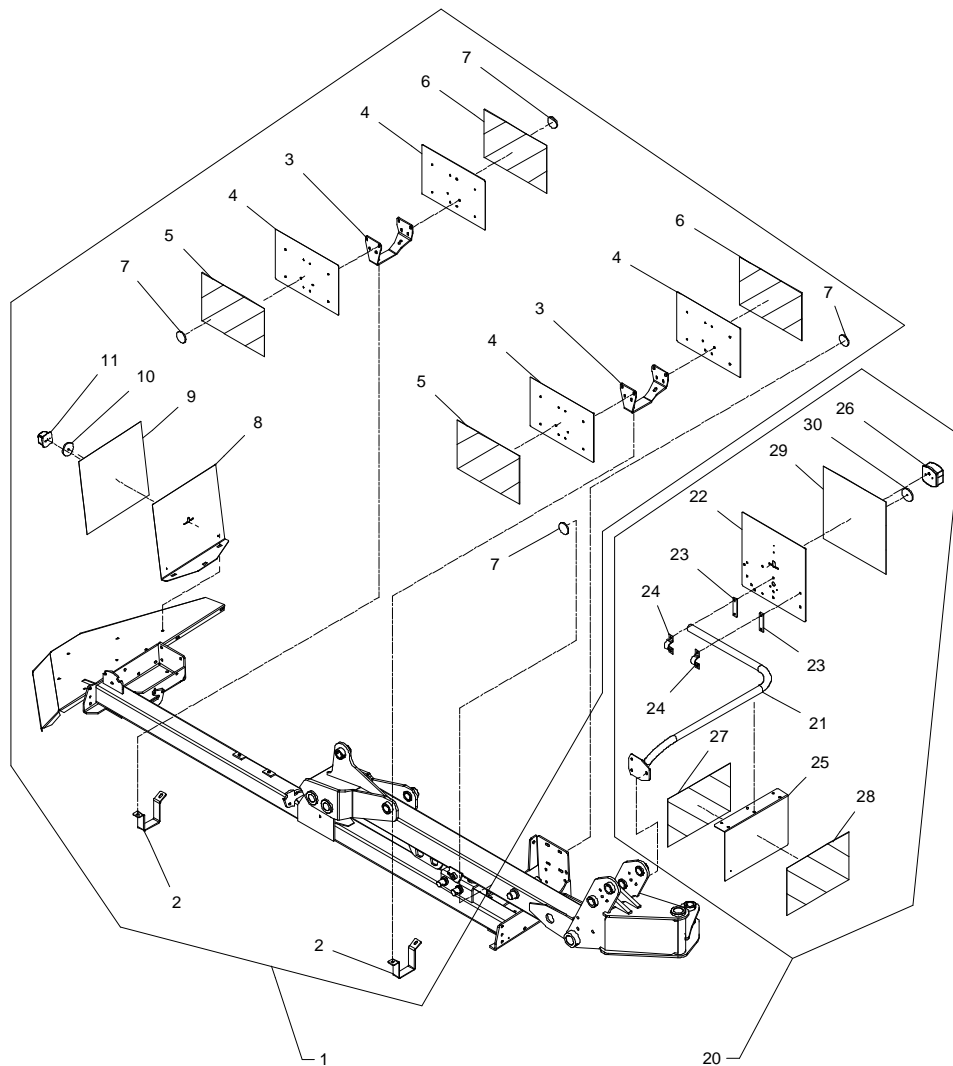

POS.	VARENUMMER	ANTAL	BENÆVNELSE	BEZEICHNUNG	DESIGNATION		
1.	4321-6001	1	LYSDSTYR HORIZONTAL LICHTSATZ, HORIZONTAL		LIGHTEQUIPMENT, HORIZONTAL		
2.	2322-229X	2	BESLAG BESCHLAG		SUPPORT	1213-3322 1215-3320 1220-3321 1241-2401	1 1 2 3
3.	2322-228X	2	BESLAG BESCHLAG		SUPPORT		
4.	1611280	4	ADVARSELSTAVLE RUSTFRIT WARNTAFEL ROSTFREI		WARNING PANEL STAINLESS	1213-2222 1220-2321 1241-1202	4 4 4
5.	PR80-6605	2	SELVKLEBENDE ADVARSELSFOLIE SELBSTKLEBENDE WARNFOLIE		SELF-ADHESIVE WARNING FOIL		
6.	PR80-6606	2	SELVKLEBENDE ADVARSELSFOLIE SELBSTKLEBENDE WARNFOLIE		SELF-ADHESIVE WARNING FOIL		
7.	1391-0612	4	REFLEX GUL RÜCKSTRAHLER GELB		REFLECTOR YELLOW		
8.	2322-254X	1	HOLDER HALTER		SUPPORT	1213-3126 1216-1156 1220-1322 1220-3321 1241-2401	2 1 1 2 4
9.	PR80-6604	1	SELVKLEBENDE ADVARSELSFOLIE SELBSTKLEBENDE WARNFOLIE		SELF-ADHESIVE WARNING FOIL		
10.	1391-0600	1	REFLEX RØD RUECKSTRAHLER ROT		REFLECTION RED		
11.	1391-1003	1	LYGTESET LICHT SATZ		LIGHT EQUIPMENT		
20.	4321-6002	1	LYSDSTYR VERTIKAL LICHTSATZ, VERTIKAL		LIGHTEQUIPMENT, VERTIKAL		
21.	3322-220X	1	HOLDER HALTER		SUPPORT	1213-4324 1220-4321	3 3
22.	2520-183X	1	ADVARSELSSKILT WARNTAFEL ROSTFREI		WARNING SIGN		
23.	0661380	2	MELLEMLÆGSPLADE ZWISCHENPLATTE		INTERMEDIATE PLATE	1215-2224 1216-1156 1220-1322 1220-2321 1241-1405	2 1 1 2 1
24.	1311-8648	2	RØRHOLDER, GALV. ROHRSCHELLE		SUPPORT FOR TUBE		
25.	2322-224X	1	HOLDER HALTER		SUPPORT	1219-0926 1220-3321 1241-2401	2 4 4
26.	1391-1001	1	LYGTESET GXS 2805-3205 LICHTSATZ GXS 2805-3205		LIGHTSET GXS 2805-3205		
27.	PR80-6605	1	SELVKLEBENDE ADVARSELSFOLIE SELBSTKLEBENDE WARNFOLIE		SELF-ADHESIVE WARNING FOIL		
28.	PR80-6606	1	SELVKLEBENDE ADVARSELSFOLIE SELBSTKLEBENDE WARNFOLIE		SELF-ADHESIVE WARNING FOIL		
29.	PR80-6604	1	SELVKLEBENDE ADVARSELSFOLIE SELBSTKLEBENDE WARNFOLIE		SELF-ADHESIVE WARNING FOIL		
30.	1391-0600	1	REFLEX RØD RUECKSTRAHLER ROT		REFLECTION RED		

Fig. 82

TILBEHØR - ZUBEHÖR - ACCESSORIES

GXS-0002/1 GXS 3205

FIG. 82.
TILBEHØR, ZUBEHÖR, ACCESSORIES

>=2840101401

HERTIL, DAZU,
TO THIS, A CECI

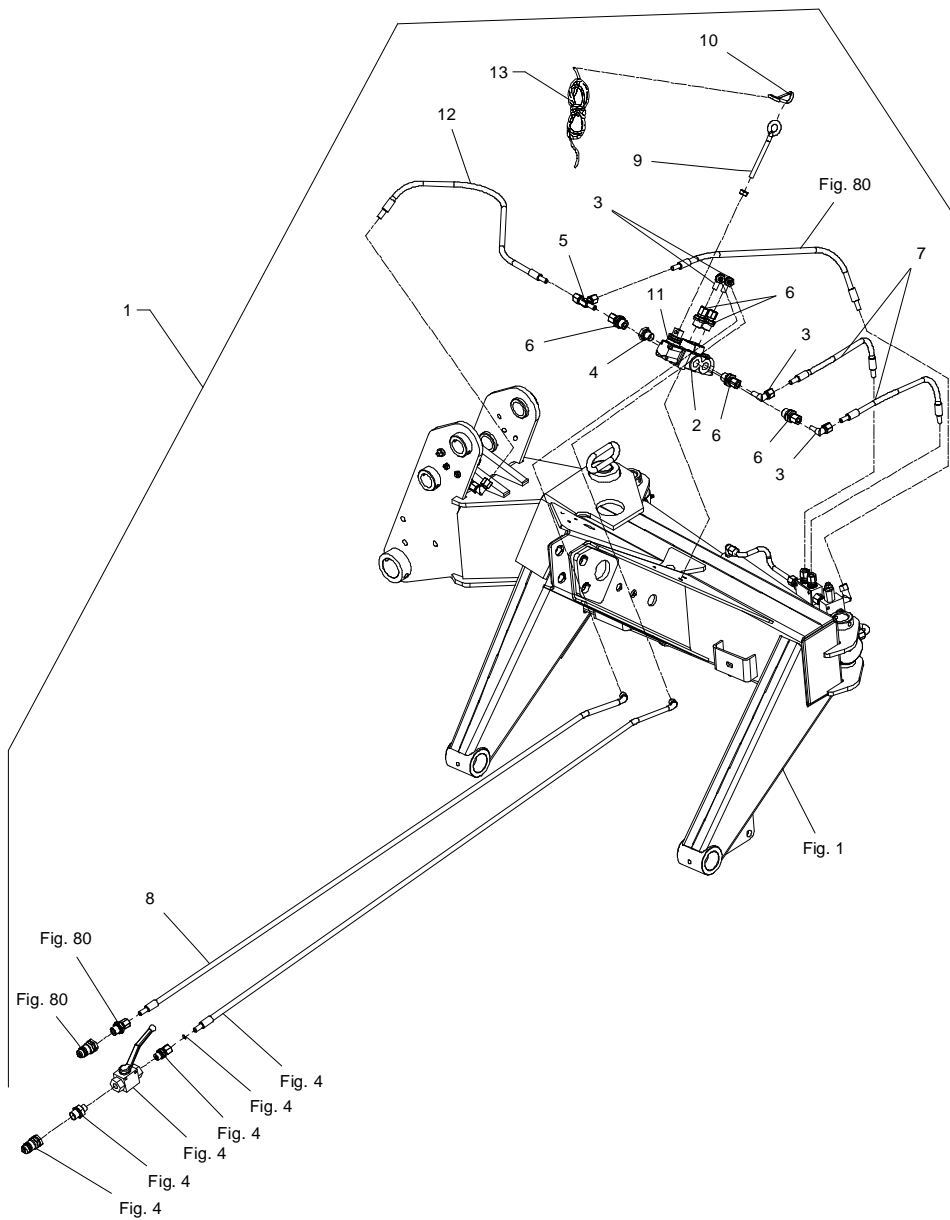

POS.	VARENUMMER	ANTAL	BENÆVNELSE	BEZEICHNUNG	DESIGNATION		
1.	4321-1011	1	OMSTIL. VENTIL STENUDLØSER UMSTELLVENTIL STEINAUSLØSER		SWITCHVALVE STONE RELEASE		
2.	1317-0576	1	VENTIL VENTIL		VALVE	1214-2228	2
						1220-2321	2
						1220-3122	1
3.	1311-8603	4	VINKELFORSKRUNING WINKELVERSCHRÄUBUNG		ANGLE COUPLING		
4.	1311-8563	1	SLUTPROP ROHRVERSCHLUSS		PLUG		
5.	1311-7025	1	T-STYKKE T-STUECK		T-PIECE		
6.	1311-1409	5	RØRFORSKRUNING ROHRVERSCHRÄUBUNG		PIPE COUPLING		
7.	1317-5017	2	SLANGE 1/4"-600 SCHLAUCH 1/4"-600		HOSE 1/4"-600		
8.	1317-5011	1	SLANGE 1/4"-1500 SCHALUCH 1/4"-1500		HOSE 1/4"-1500		
9.	1392-0507	1	ØJEBOLT M10 GALV AUGBOLZEN M10 GALV		EYE BOLT M10 GALV		
10.	1399-0121	1	KARABINHAGE KARABINHAKEN		SNAP HOOK		
11.	1317-9418	1	GUMMIBELG GUMMIBALG		RUBBER TIGHTENING		
12.	1317-5010	1	SLANGE 1/4"-950 SCHALUCH 1/4"-950		HOSE 1/4"-950		
13.	2365-403X	1	SNOR SEIL		STRING		

Valid from: | Gültig ab:
Valable à partir de: | Gyldig fra:
21. 03. 2011

Serial No.: | Maschinen Nr.:
No. de serie: | Fabrikationsnr.:
2840101401