



Grundindstillinger for slåmaskiner

Indeks

GD 2800-3205 FM, GD 3205 F	2
GXF 3205-3605 P	2
CM 265-305F	2
GX 2402-3202, GX 2402-3202 SM, 2405-3205, 2405-3205 SM, CM 305.....	3
GX 7005, GX 9005, GX 9005 SM.....	3
SB 200-240, SB 2402-2802, CM 170-190	3
SM 2805, SM 3205	4
GMS 2800-3600 FLEX/TS, GMS 2802-3202 FLEX/TS, GMS 280/320, GFS 3205 FLEX/TS .	5
GMT 3205-3605 FLEX P/R/S	6
GMS 4802 In Line / Dual Line.....	7
GXT 12005 / 12005 SM / 13005 P / 15005 SM	8



Grundindstillinger for maskiner

GD 2800-3205 FM, GD 3205 F

PTO = 1000 rpm, med uret set bagfra.

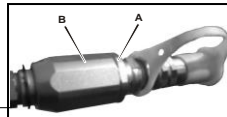

Hævehastigheden kan indstilles med drøvleventil

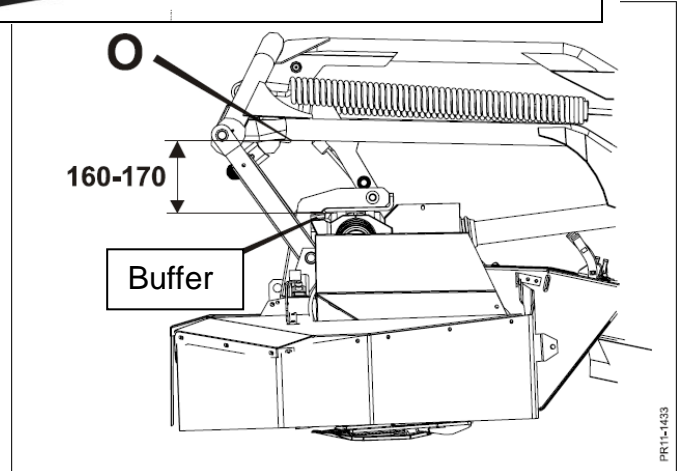
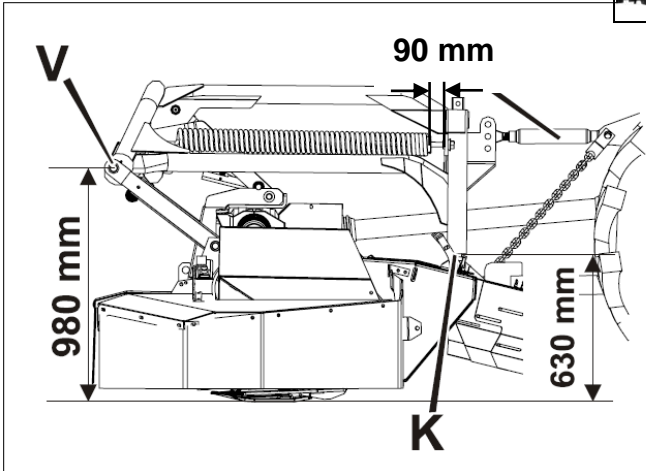

GXF 3205-3605 P

PTO = 1000 rpm, med uret set bagfra.

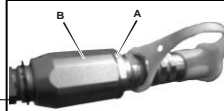

Sænkehastigheden kan indstilles med drøvleventil

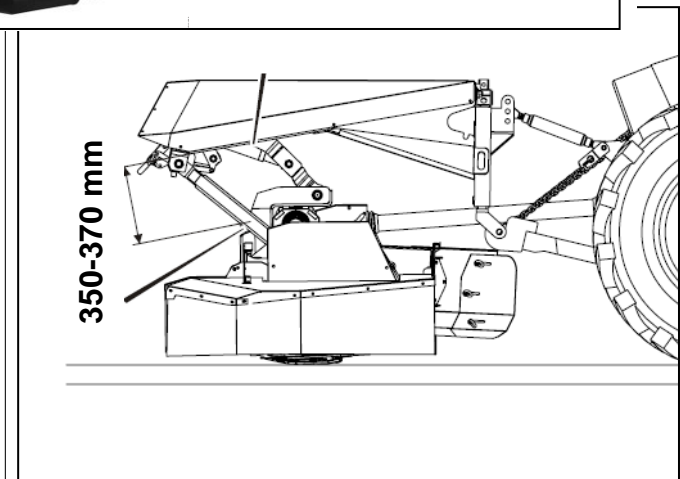
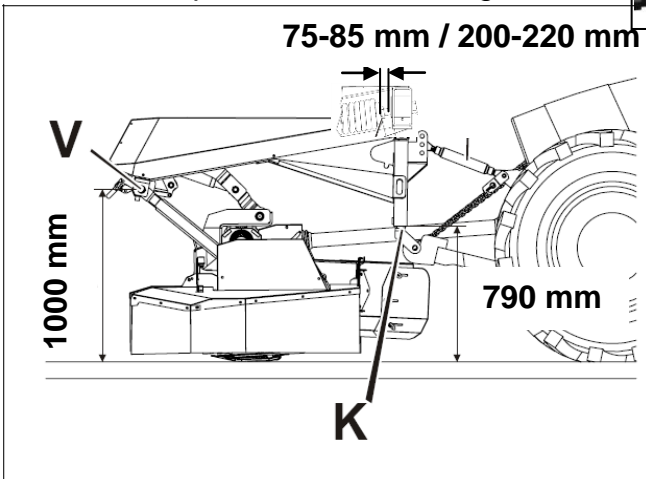

CM 265-305F

PTO = 1000 rpm

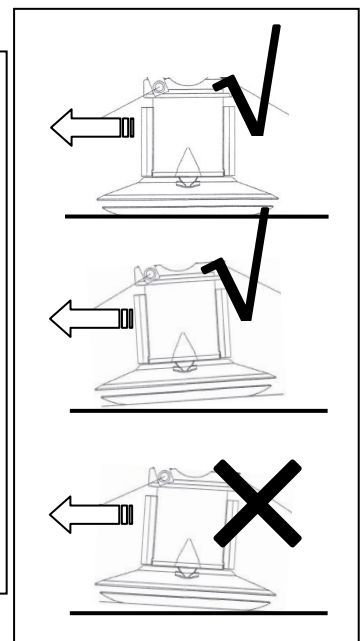
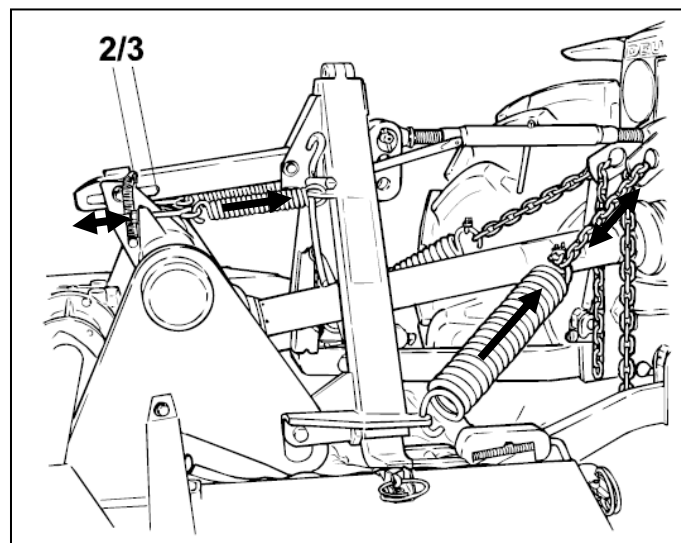



Grundindstillinger for maskiner

GX 2402-3202, GX 2402-3202 SM, 2405-3205, 2405-3205 SM, CM 305

PTO = 540 / 1000 rpm

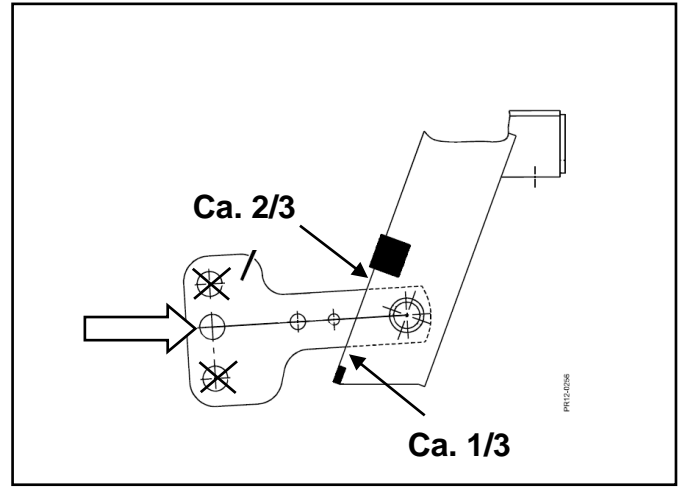
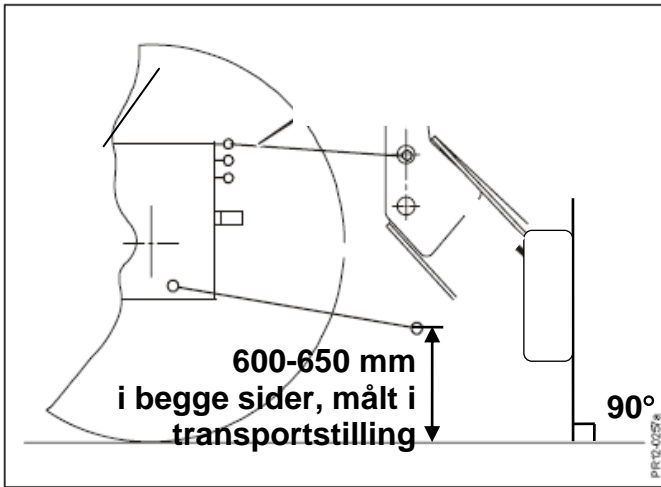

GX 7005, GX 9005, GX 9005 SM

PTO = 1000 rpm

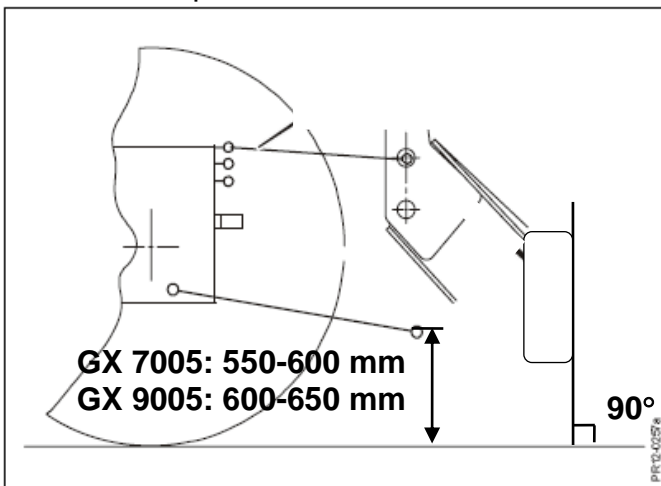

SB 200-240, SB 2402-2802, CM 170-190

PTO 540 rpm

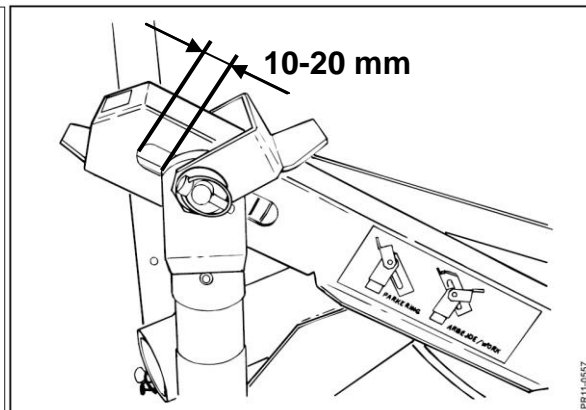
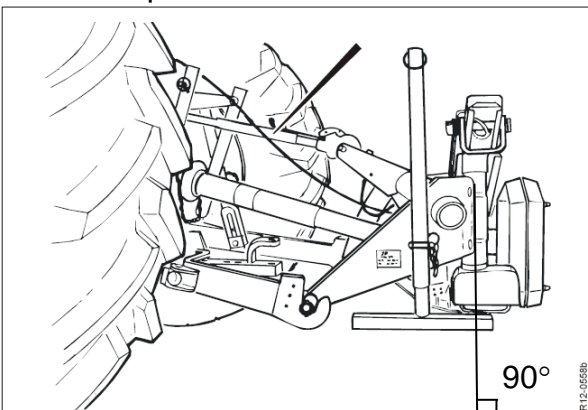



SM 2805, SM 3205

PTO = 540 rpm

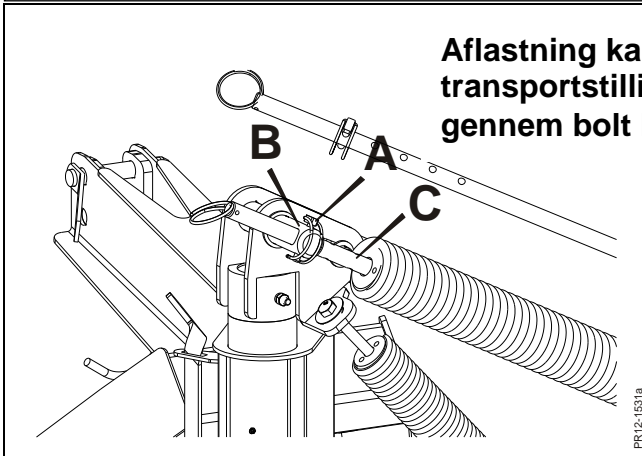
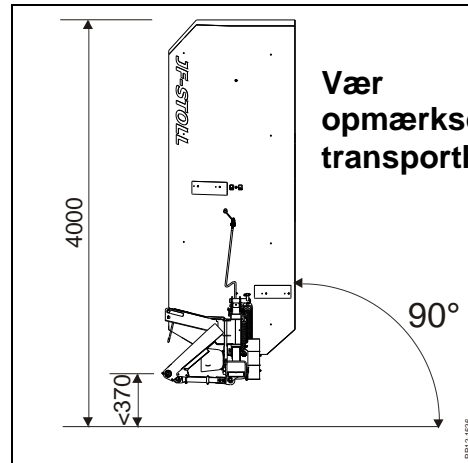
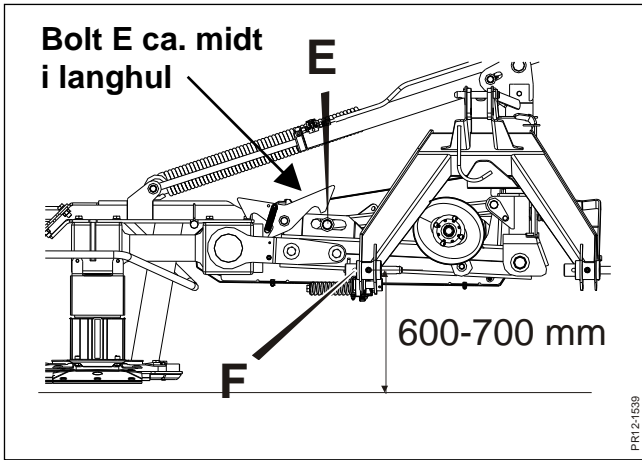

GMS 2800-3600 FLEX/TS, GMS 2802-3202 FLEX/TS, GMS 280/320, GFS 3205 FLEX/TS

PTO = 1000 rpm / (540 rpm)

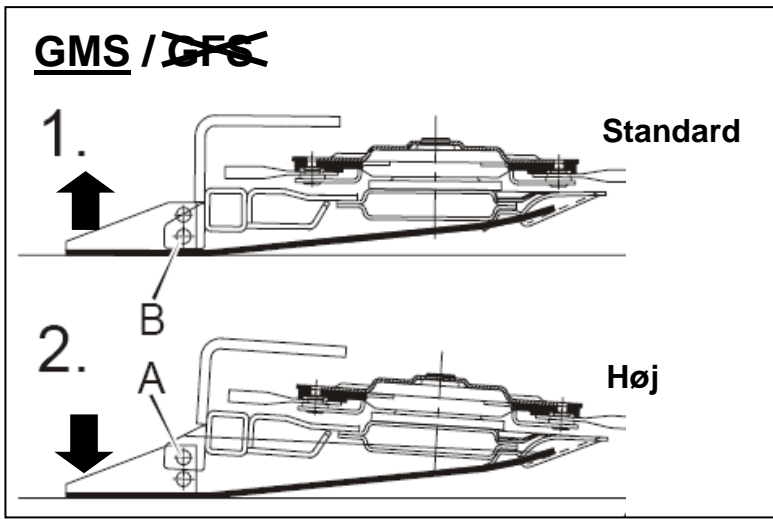
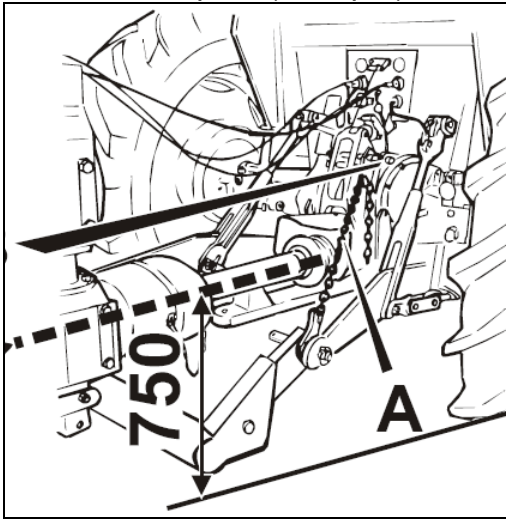

Indstilles med trækstangen i midterstilling og skæreenheden helt nedsænket

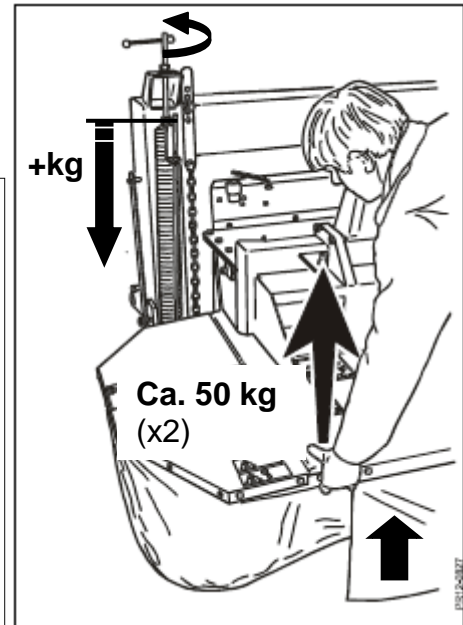
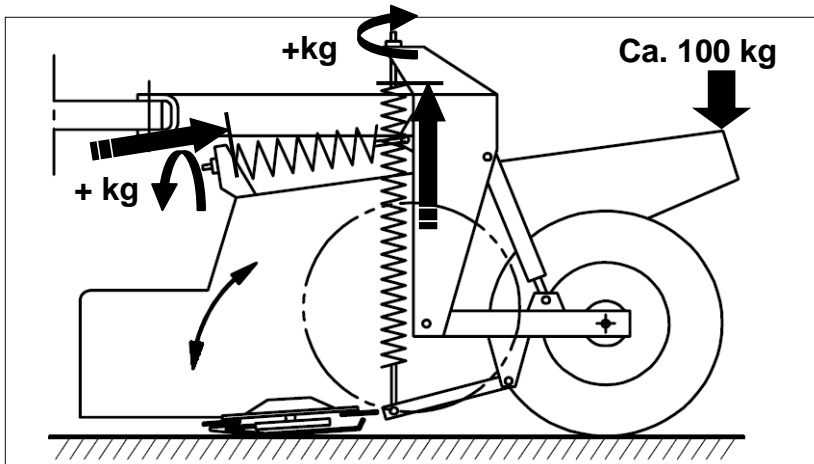



GMT 3205-3605 FLEX P/R/S

PTO = 1000 rpm

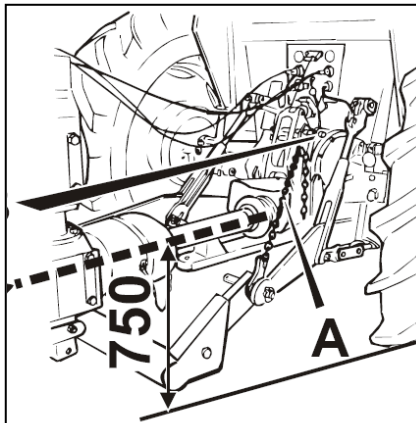

Indstilles med trækstangen i midterstilling og skæreenheden helt nedsænket

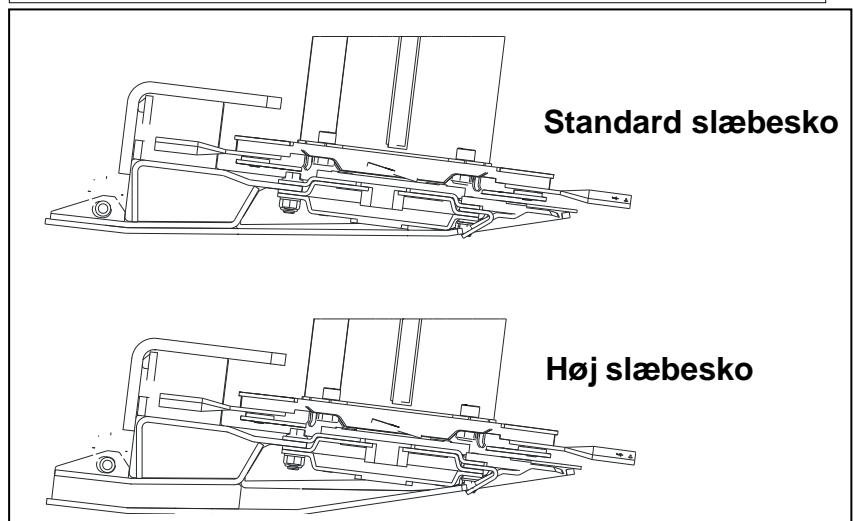
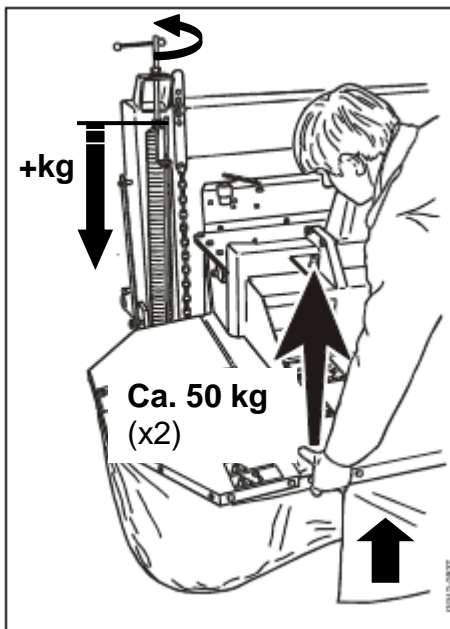
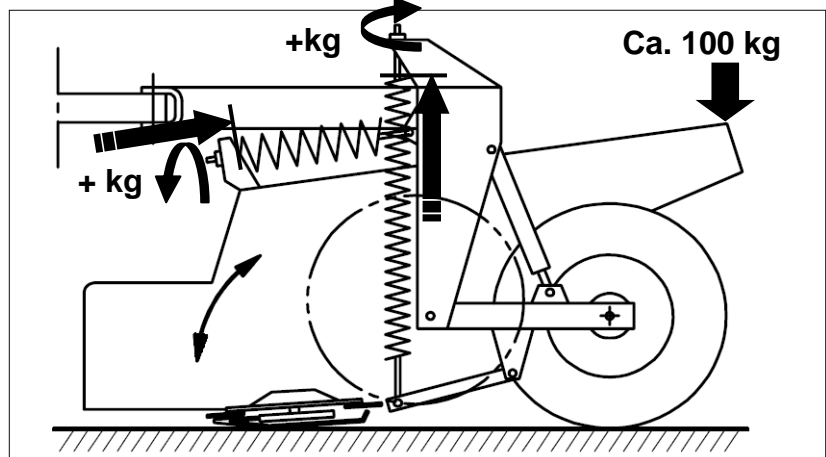



GMS 4802 In Line / Dual Line

PTO = 1000 rpm

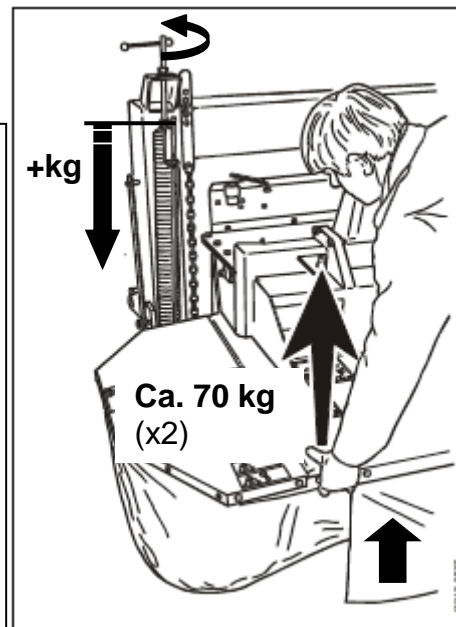
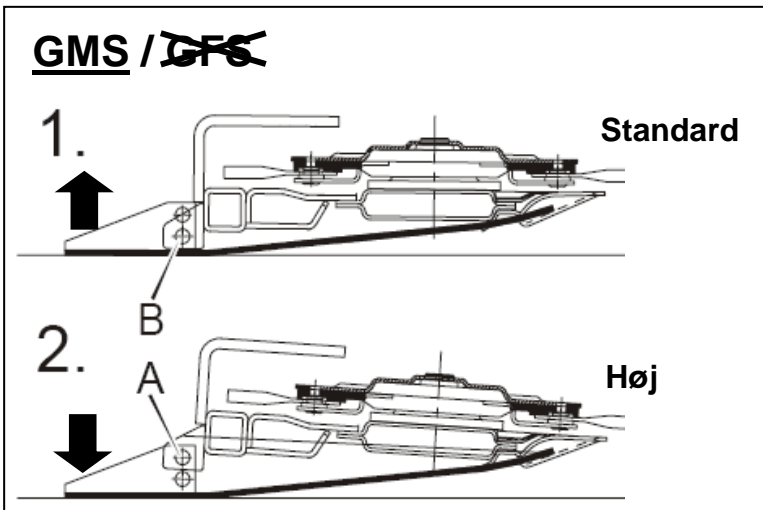
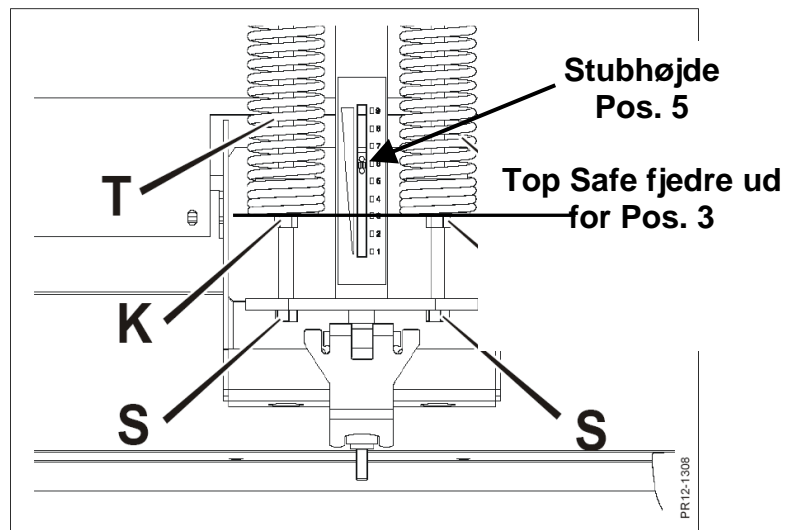
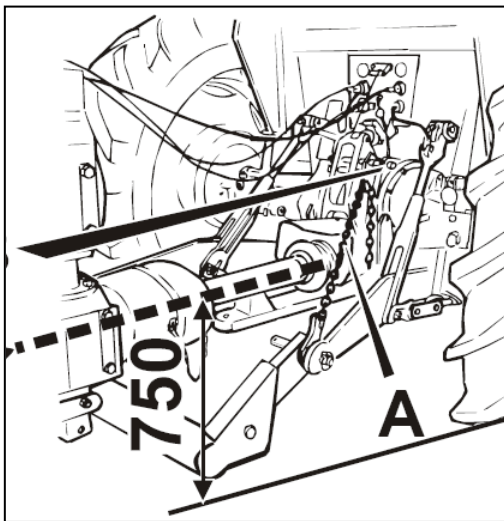



GXT 12005 / 12005 SM / 13005 P / 15005 SM

PTO =1000 rpm

